

# TM 11-5826-215-12

DEPARTMENT OF THE ARMY TECHNICAL MANUAL

*Per Change 1, 16 July 1962, title of manual is changed to read as follows:  
Per Change 5, 10 June 1965, title of manual is changed to read as follows:*



~~OPERATOR AND~~ ORGANIZATIONAL  
MAINTENANCE MANUAL;

RECEIVING SET,  
RADIO AN/ARN-30D

*AND AN/ARN-30E*

*INCLUDING REPAIR PARTS AND SPECIAL TOOL LISTS*

PROPERTY OF TECHNICAL LIBRARY  
FOR REFERENCE

Not To Be Taken From This Room

*Cover only*



HEADQUARTERS, DEPARTMENT OF THE ARMY  
21 AUGUST 1961

*Copy 1/2*

## **WARNING**

**DANGEROUS VOLTAGES EXIST IN THIS EQUIPMENT**

**DON'T TAKE CHANCES!**

### **DANGEROUS VOLTAGES EXIST IN:**

Power Supply PP-2792/ARN-30D; Receiver, Radio R-1021/ARN-30D; Converter, Signal Data CV-265A/ARN-30A, and associated interconnecting wiring when the VOL-OFF switch on Control, Radio Set C-3436/ARN-30D is taken out of the OFF position.

# RECEIVING SET, RADIO AN/ARN-30D

		Paragraph	Page
CHAPTER	1.	INTRODUCTION	5
Section	I.	General	5
		Scope .....	1 5
		Forms and records .....	2 5
	II.	Description and data	5
		Purpose and use .....	3 5
		Technical characteristics .....	4 5
		Table of components .....	5 7
		Nomenclature and common name .....	6 8
		Description of antenna .....	7 8
		Description of vhf navigation control unit .....	8 8
		Description of converter .....	9 8
		Description of course indicator .....	10 9
		Description of mounting .....	11 9
		Description of rack .....	12 10
		Description of power supply .....	13 10
		Description of vhf navigation receiver .....	14 11
		Additional equipment required .....	15 11
		System application .....	16 12
CHAPTER	2.	OPERATING INSTRUCTIONS	13
Section	I.	Operator's controls and indicators	15
		Vhf navigation control unit, operator's controls and indicators .....	17 15
		Course indicator, operator's controls and indicators .....	18 15
	II.	Operation under usual conditions	15
		Types of operation .....	19 16
		Operating limitations .....	20 16
		Starting procedure .....	21 17
		Determining aircraft bearing relative to VOR station .....	22 17
		Flying course to or from VOR station .....	23 18
		Making VOR approach .....	24 19
		Flying to objective other than VOR station .....	25 20
		Making approximate ground-speed checks .....	26 21
		Making front course localizer approaches .....	27 23
		Making back course localizer approaches .....	28 23
		Intersecting localizer signal using VOR station .....	29 23
		Operating as communication equipment .....	30 27
		Stopping procedure .....	31 28
Section	III.	Operation under unusual conditions	28
		Emergency operation .....	32 28
		Jamming and anti-jamming .....	33 28
	IV.	Operator's inspection procedure	29
		Extent of coverage .....	34 29
		Preflight inspections, power off .....	35 29
		Preflight inspections, power on .....	36 30
		Flight inspection .....	37 31
CHAPTER	3.	ORGANIZATIONAL MAINTENANCE INSTRUCTIONS	32
Section	I.	General	32
		Scope of maintenance instructions .....	38 32
		Preventive maintenance .....	39 32
	II.	Corrective maintenance	33
		Visual inspection .....	40 33
		Equipment performance checklist .....	41 33
		Removal and replacement of vhf navigation control unit panel lamps .....	42 35

		Paragraph	Page
	Removal and replacement of vhf navigation control unit and course indicator knobs .....	43	35
	Removal and replacement of major components of vhf navigation set ...	44	35
CHAPTER	4. DEMOLITION OF MATERIEL TO PREVENT ENEMY USE		38
	Authority for demolition .....	45	38
	Methods of destruction .....	46	38
APPENDIX	I. REFERENCE .....		39
	II. MAINTENANCE ALLOCATION .....		40
	III. BASIC ISSUE ITEMS LIST .....		47
GLOSSARY	.....		50

1  
2  
3  
4  
5  
6  
7  
8  
9  
10  
11  
12  
13  
14  
15  
16  
17  
18  
19  
20  
21  
22  
23  
24  
25  
26  
27  
28  
29  
30  
31  
32  
33  
34  
35  
36  
37  
38  
39  
40  
41  
42  
43  
44  
45  
46  
47  
48  
49  
50  
51  
52  
53  
54  
55  
56  
57  
58  
59  
60  
61  
62  
63  
64  
65  
66  
67  
68  
69  
70  
71  
72  
73  
74  
75  
76  
77  
78  
79  
80  
81  
82  
83  
84  
85  
86  
87  
88  
89  
90  
91  
92  
93  
94  
95  
96  
97  
98  
99  
100

CHAPTER 1  
INTRODUCTION

This page left blank intentionally.



POWER SUPPLY  
PP-2792/ARN-30D

RECEIVER,  
RADIO  
R-1021/ARN-30D

CONVERTER,  
SIGNAL DATA  
CV-265A/ARN-30A

MOUNTING  
MT-1174/ARN-30A

MOUNTING  
MT-1175/ARN-30A

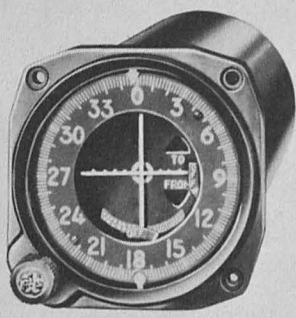

INDICATOR, COURSE ID-453/ARN-30

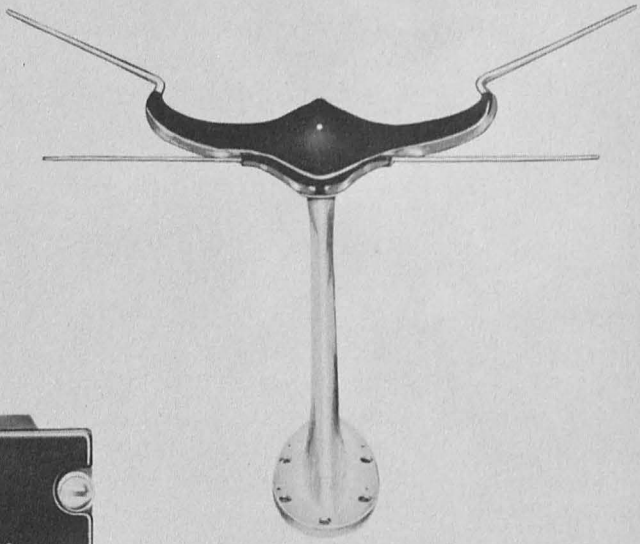

ANTENNA AS-580A/ARN-30



CONTROL, RADIO SET C-3436/ARN-30D

TM5826-215-12-1

Figure 1. Receiving Set, Radio AN/ARN-30D.

# CHAPTER 1

## INTRODUCTION

---

### Section I. GENERAL

#### 1. Scope

This manual describes Receiving Set, Radio AN/ARN-30D (fig. 1) and covers the operating instructions to be used by the aircraft pilot, copilot, and crewmembers performing navigation procedures and organizational maintenance procedures to be performed by the organizational repairman or aircraft crew chief. It includes preflight, flight, and functional checks for verifying normal operation of the equipment, and replacement of components and parts available to second echelon maintenance personnel.

#### 2. Forms and Records

*a. Unsatisfactory Equipment Reports.* Fill out and forward DA Form 468 (Unsatisfactory Equipment Report) to the Commanding Officer, U. S. Army Signal Materiel Support Agency, ATTN: SIGMS-ML, Fort Monmouth, N. J., as prescribed in AR 700-38.

*b. Report of Damaged or Improper Shipment.* Fill out and forward DD Form 6 (Report of Damaged or Improper Shipment) as prescribed in AR 700-58 (Army).

*c. Maintenance Forms.* Prepare DA Form 2391-2 (Aircraft Flight Report and Maintenance Record — Aircraft Inspection and Maintenance) in accordance with instructions on the form. All postflight and preflight inspections will be recorded on this form.

*d. Parts Lists Form.* Forward DA Form 2028 (Recommended Changes to DA Technical Manual Parts Lists or Supply Manuals Parts Lists or Supply Manuals 7, 8, and 9) direct to the Commanding Officer, U. S. Army Signal Materiel Support Agency, ATTN: SIGMS-ML, Fort Monmouth, N. J., with comments on parts listings.

*e. Comments on Manual.* Forward all other comments on this publication direct to the Commanding Officer, U. S. Army Signal Materiel Support Agency, ATTN: SIGMS-PA2d, Fort Monmouth, N. J.

### Section II. DESCRIPTION AND DATA

#### 3. Purpose and Use

*a.* Receiving Set, Radio AN/ARN-30D is an airborne, very high-frequency (vhf) radio set which provides for reception of 190 vhf channels whose frequencies are at all the 0.1-megacycle (mc) steps between 108.00 mc and 126.90 mc. Operation in this frequency range permits reception and interpretation of vhf omnidirectional radio range (VOR) signals and of localizer signals broadcasted by ground stations. Reception and interpretation of these signals provide the operator with data used in navigation.

*b.* The navigational data enable the operator to perform the following:

- (1) Determine the bearing of the aircraft with respect to a VOR station.
- (2) Fly a desired course to or from a VOR station.
- (3) Fly to an objective other than a VOR station.
- (4) Make approximate groundspeed checks.
- (5) Fly to the intersection of a localizer and VOR signal.
- (6) Approach a runway associated with either a VOR or a localizer station.

*c.* Receiving Set, Radio AN/ARN-30D has provisions for connection to a vhf

transmitter. When connected to a vhf transmitter, Receiving Set, Radio AN/ARN-30D, which is primarily a navigation set, can also be used as a communication set. Certain portions of this equipment (Indicator, Course ID-453/ARN-30) can also be added to components of other equipment to permit glide-slope navigation procedures to be performed.

d. Figure 2 is a block diagram showing the operation of Receiving Set, Radio AN/ARN-30D. Both VOR and localizer navigation signals broadcasted by ground stations are induced into Antenna AS-580A/ARN-30. Receiver, Radio R-1021/ARN-30D is tuned to the signals at the antenna by frequency selection signals developed in Control, Radio Set C-3436/ARN-30D. Tuning Receiver, Radio R-1021/ARN-30D to these signals produces audio and navigation data outputs. Audio outputs are applied to the intercommunication system of

the aircraft to permit voice and/or code signals to be heard by the operator.

e. Navigation data outputs of Receiver, Radio R-1021/ARN-30D are applied to Converter, Signal Data CV-265A/ARN-30A which, in turn, processes either VOR or localizer navigation signals; the signal type selected is determined by a signal from Control, Radio Set C-3456/ARN-30D. The output of Converter, Signal Data CV-265A/ARN-30A is displayed on Indicator, Course ID-453/ARN-30 to show the bearing of the aircraft relative to the VOR station or to the localizer station. An output from a glide-slope receiver is displayed on Indicator, Course ID-453/ARN-30 when a glide-slope receiver is being used. High voltage required for operation of Receiver, Radio R-1021/ARN-30D and Converter, Signal Data CV-265A/ARN-30A is supplied by Power Supply PP-2792/ARN-30D.

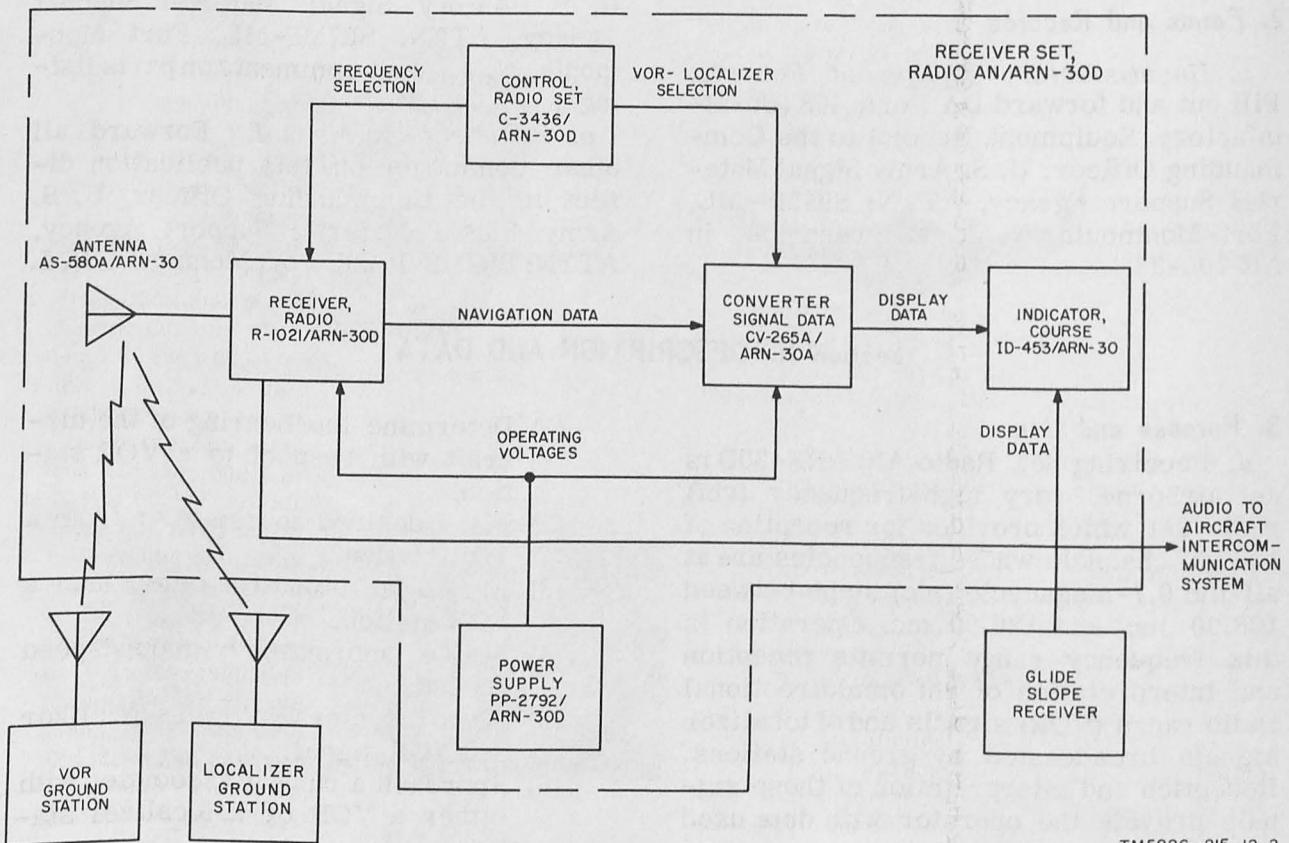

TM5826-215-12-2

Figure 2. Receiving Set, Radio AN/ARN-30D, operational block diagram.



## 4. Technical Characteristics

### a. Receiving Set, Radio AN/ARN-30D.

Total input power. . . . 2.5 amperes at 28 volts dc (70 watts).

Total weight. . . . . Approximately 26 pounds.

### b. Antenna AS-580A/ARN-30.

Type. . . . . Two broadband dipoles.

### c. Control, Radio Set C-3436/ARN-30D.

Input power. . . . . 80 ma at 28 volts dc (2.24 watts).

### d. Converter, Signal Data CV-265A/ARN-30A.

Input power. . . . . 0.52 ampere at 28 volts dc (14.56 watts).

High-voltage power . . . 22 ma at 260 volts dc (5.72 watts) (VOR operation),  
7 ma at 260 volts dc (1.82 watts) (localizer operation).

### e. Indicator, Course ID-453/ARN-30.

Pointer sensitivity . . . 150 ± 7.5 microamperes.

Flag sensitivity. . . . . 245 ± 11 microamperes.

TO-FROM meter sensitivity. . . . . 90 ± 15 microamperes.

Selector dial. . . . . 36° compass scale, marked every 2°.

### f. Power Supply PP-2792/ARN-30D.

Input power. . . . . 1.22 amperes at 26 volts dc (31.72 watts) (100-ma output).

Efficiency . . . . . 85% (100-ma output).

Temperature rise . . . . 11° C or less (100-ma output).

Ripple. . . . . 0.3%.

Output voltage . . . . . 260 volts dc at 100 ma.

Output current. . . . . 200 ma maximum, continuous at 55° C; 100 ma maximum, continuous at 71° C; 200 ma maximum, intermittent at 71° C.

Regulation . . . . . 2% (15- to 150-ma output).

### g. Receiver, Radio R-1021/ARN-30D.

Frequency range . . . . 108.00-126.90 mc.

Number of channels . . . 190.

Channel spacing . . . . 100 kc (0.1 mc).

Channeling time . . . . 4 seconds maximum.

Input power. . . . . 1.8 amperes at 28 volts dc (50.4 watts).

High-voltage power . . . 85 ma at 260 volts dc (22.1 watts).

Types of signals received. . . . . VOR, localizer, and communication.

Weight. . . . . 6.7 pounds.

Type. . . . . Superheterodyne, double-conversion, crystal-controlled.

Type of modulation. . . . Amplitude.

Input impedance. . . . . 50 ohms.

Number of tubes . . . . . 14.

Sensitivity . . . . . 6 db signal-plus-noise to noise with 3 microvolts (measured across a 50-ohm source), maximum at 1,000 cps, 30% modulation. Agc knee no higher than 5 microvolts.

Bandwidth . . . . . 6 db down ±24 from center frequency.  
60 db down ±70 kc from center frequency.

Tuning. . . . . Electrically actuated, crystal-controlled. Nineteen crystals on megacycle drum; fundamental frequency range; 48.15 to 57.15 mc in 0.5-mc steps. Ten crystals on fractional megacycle drum; frequency range: 10.00 to 10.90 mc in 0.1-mc steps.

Intermediate frequencies:

First if. . . . . Variable from 11.70 to 12.60 mc.

Second if. . . . . 1.7 mc (fixed).

If. rejection . . . . . 100 db, minimum.

Image rejection . . . . . 70 db, minimum.

Spurious response rejection. . . . . 80 db, minimum.

Agc. . . . . Output constant within 4.5 db from 10 to 200,000 microvolts.

Audio output. . . . . With 1,000 cps, 30% modulation, 108.00 to 117.90 mc, at least 300 milliwatts into 300 ohms.  
With 1,000 cps, 30% modulation, 118.00 to 126.90 mc, at least 70 milliwatts into 300 ohms.  
With 1,000 cps, 85% modulation, 118.00 to 126.90 mc, at least 300 milliwatts into 300 ohms.

Squelch sensitivity. . . . Adjustable from 0.1 to 5 microvolts (may be extended to 15 microvolts by adjustment of if. sensitivity control, which also affects agc knee).

Total harmonic distortion. . . . . Less than 25% with 100 microvolts, 350- to 2,500-cps modulation.

Audio frequency response. . . . . Within 6 db of rated output from 350 cps to 2,500 cps.

## 5. Table of Components (fig. 1)

The components of Receiving Set, Radio AN/ARN-30D are listed in the following table.

Quantity	Item	Height (in.)	Depth (in.)	Width (in.)	Unit weight (lb)
1	Antenna AS-580A/ARN-30 .....	10-1/4	28	21-1/4	3.6
1	Control, Radio Set C-3436/ARN-30D .....	2-1/4	5-3/4	3-3/4	1.4
1	Converter, Signal Data CV-265A/ARN-30A .....	5-1/2	4-3/4	11-1/2	6.1
1	Indicator, Course ID-453/ARN-30.....	3-1/4	3-1/4	7-1/4	3.3
1	Mounting MT-1174/ARN-30A .....	1-1/2	11-13/16	10-29/32	0.8
1	Mounting MT-1175/ARN-30A .....	3-7/8	11	13-1/8	2.3
1	Power Supply PP-2792/ARN-30D .....	3-3/8	4-15/16	2-15/16	1.7
1	Receiver, Radio R-1021/ARN-30D .....	5-1/2	4-5/8	11-3/16	6.7

## 6. Nomenclature and Common Name.

A list of the nomenclature assignments for the components of Receiving Set, Radio AN/ARN-30D is given below. A common name is indicated after each item.

Nomenclature	Common name
Receiving Set, Radio AN/ARN-30D.	Vhf navigation set.
Antenna AS-580A/ARN-30 ..	Antenna.
Control, Radio Set C-3436/ARN-30D.	Vhf navigation control unit.
Converter, Signal Data CV-265A/ARN-30A.	Converter.
Indicator, Course ID-453/ARN-30.	Course indicator.
Mounting MT-1174/ARN-30A.	Mounting.
Mounting MT-1175/ARN-30A.	Rack.
Power Supply PP-2792/ARN-30D.	Power supply.
Receiver, Radio R-1021/ARN-30D.	Vhf navigation receiver.

## 7. Description of Antenna (fig. 3)

a. The antenna is a *rams-horn* antenna with two dipoles. The forward (short) dipole is used as a glide-slope antenna and is used for glide-slope signal reception if such equipment is installed in the aircraft. The V-shaped rear dipole is the VOR and localizer antenna and is used for reception of VOR and localizer signals.

b. Each antenna is terminated with a

UG-291/U coaxial connector, located in the antenna base. The dipoles are set in a rubber block, which is fastened to the pedestal support.

c. The pedestal support has two drainage tunnels at its base that permits the escape of accumulated moisture when the antenna is mounted in an upright position. When the antenna is mounted in an inverted position, a hole is drilled through the white-marked depression in the top of the rubber block to provide for moisture drainage.

## 8. Description of Vhf Navigation Control Unit (fig. 4)

a. The vhf navigation control unit is a single-chassis unit with operating controls and a frequency indicator on the front panel and electrical connectors on the rear panel. Lock fasteners on the sides of the front panel allow the vhf navigation control unit to be mounted in a location accessible to the pilot and copilot of the aircraft.

b. Edge-lighting of the vhf navigation control unit is provided by two midjet, flange-base lamps installed in red-filter light housing assemblies located on the front panel. Power for these lamps is brought in through a separate wire, which is to be connected to the electrical system panel-light control of the aircraft. The light is transmitted through translucent white index lines and control designations on the face of an opaque panel.

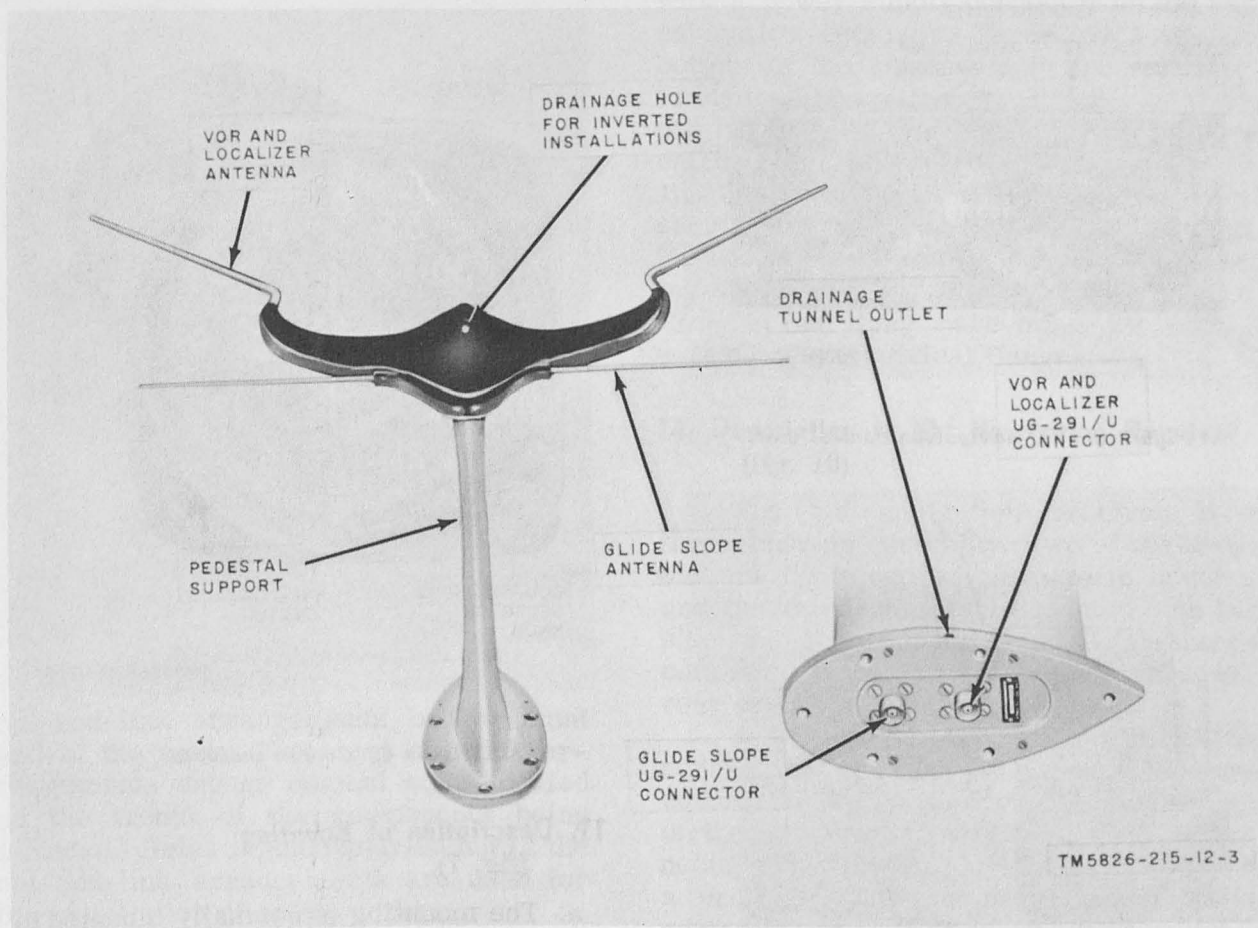

Figure 3. Antenna.

c. Light is also transmitted through translucent areas behind front-panel control knobs to a translucent white circle on each knob. When power is applied to the equipment, the translucent white areas glow red, permitting identification of the controls and their settings.

### 9. Description of Converter (fig. 5)

a. The converter is a single-chassis unit with input and output connectors located at the rear of the chassis. Conical studs on the lower right- and left-hand corners of the front panel allow the converter to be fastened on Mounting MT-1175/ARN-30A.

b. Adjustment controls on the front panel are not required for any operating

procedure, but are set and locked by an electronic navigation repairman during alignment.

### 10. Description of Course Indicator

a. The course indicator (fig. 6) is a panel-type indicator unit, consisting of six indicating elements and one control. The indicating elements, mounted behind a glass window, include horizontal and vertical pointers (fig. 12), horizontal and vertical red flag mechanisms, a TO-FROM meter, and a selector dial calibrated in degrees.

b. Fluorescent blue and yellow sectors (fig. 6) are marked in the area covered by the vertical pointer. These sectors indicate right and left deflections of the vertical pointer, which is pivoted at the top.

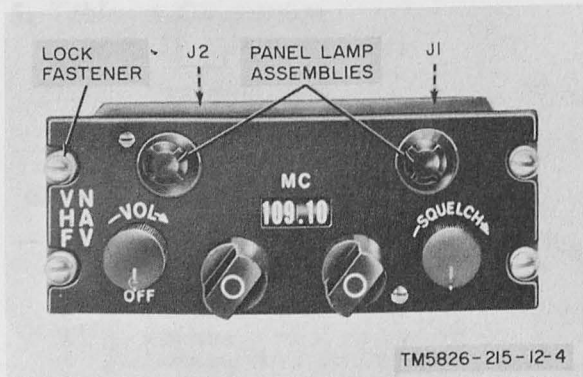

Figure 4. Vhf navigation control unit.

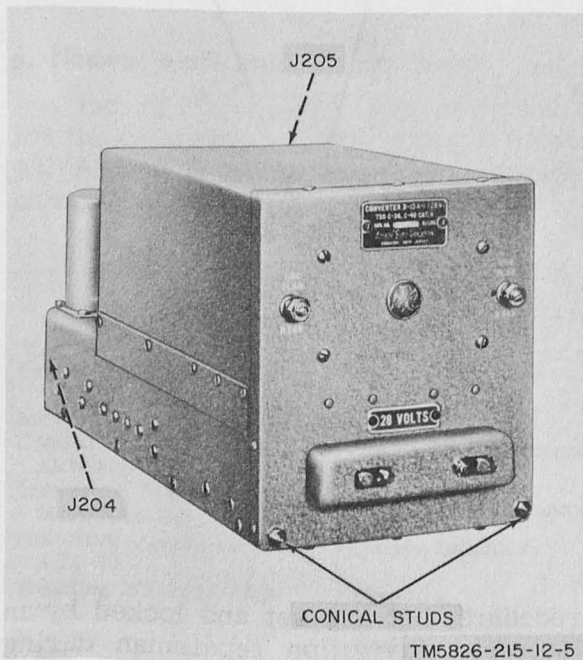

Figure 5. Converter.

The horizontal pointer (fig. 12) associated with glide-slope operation is pivoted at the left side.

c. The course and reciprocal pointers move around the outer rim of the calibrated selector dial as the course selector knob is operated.

d. Connection to other units in the vhf navigation set is provided by an electrical connector at the back of the course indicator (fig. 6). Holes in three of the indicator front-panel corners are used in the installation of the course indicator on the instrument panel of the aircraft.

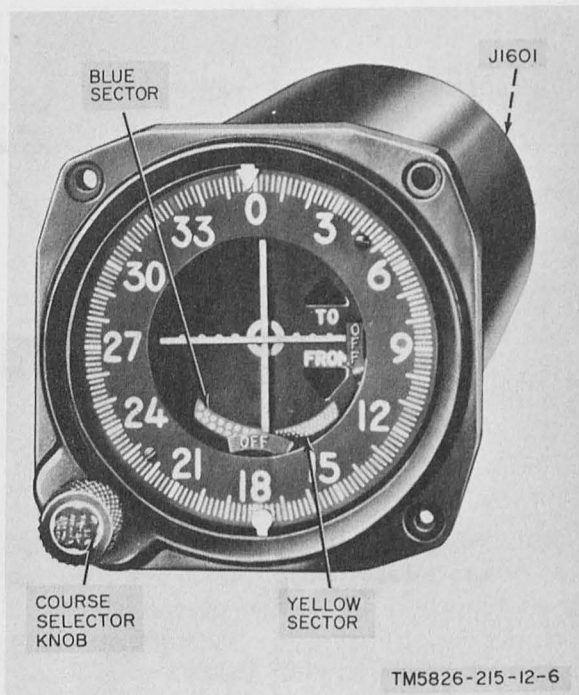

Figure 6. Course indicator.

## 11. Description of Mounting (fig. 7)

a. The mounting is normally mounted in the interior of the aircraft and supports the rack (para 12). Shock mounts are located at each corner of the mounting. Grooved studs on the shock mounts connect to snapslides on the rack to secure the rack. Holes in each of the grooved studs are used for the installation of safety wires.

b. Two ground straps, which are fastened from the two rear shock mounts to the mounting frame, ground all components that set on the mounting to minimize radio-frequency (rf) noise. Eight holes in the channel frame secure the mounting to the frame of the aircraft.

## 12. Description of Rack (fig. 8)

a. The rack provides a shock-mounted support for both the vhf navigation receiver and the converter. These components are installed in individual compartments in the rack, and are secured by

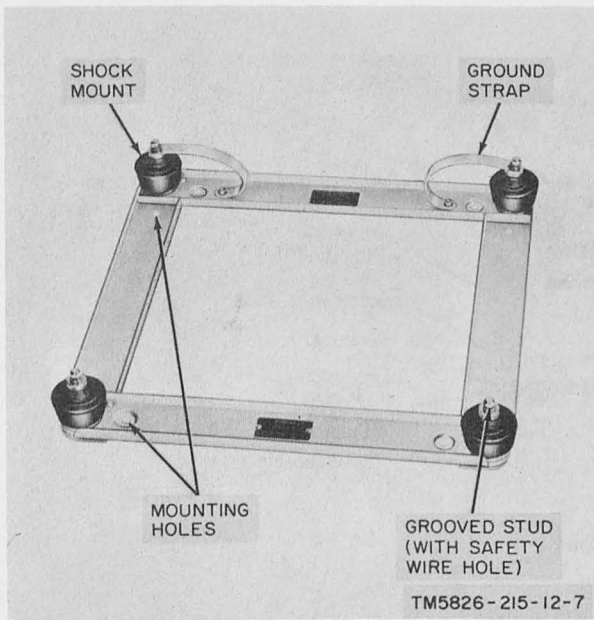

Figure 7. Mounting.

nut-and-link arrangements on the front end of the rack. These nut-and-link arrangements engage conical studs located on the fronts of the components being mounted. Holes in each knurled nut of the nut-and-link arrangements are used for the installation of safety wires.

b. The rear of the rack is a distribution box with electrical connectors on its front and top panels. The front-panel connectors mate with connectors mounted on the vhf navigation receiver and the converter. The connectors on the top of the rack are connected by cables to remotely installed units of the vhf navigation set.

c. Snapslides on the four corners of the rack are used to install the rack on the mounting. These snapslides are secured to the grooved studs on the mounting shock mounts (fig. 7). Holes in the vertical flanges of each of these snapslides (fig. 8) permit the installation of safety wires.

### 13. Description of Power Supply (fig. 9)

The power supply is a single-chassis, plug-in type unit with a fin-type cover for heat dissipation. A receptacle on the bottom of the power supply (J101) mates

with a power supply connector on the vhf navigation receiver. Three studs on the bottom of the power supply are arranged to insure correct mating. The power supply is mounted on four shock mounts located on the vhf navigation receiver (fig. 1). When mounted, the power supply is secured by four snapslide fasteners (fig. 9). These snapslides are similar to Mounting MT-1175/ARN-30A snapslides (para 12c) in that they have holes for safety wires in their vertical flanges.

### 14. Description of Vhf Navigation Receiver (fig. 10)

a. The vhf navigation receiver is a three-chassis assembly. Two of the chassis are contained within a main housing and the third chassis is located both inside the main housing and in an interconnecting box subassembly located at the rear of the main housing.

b. A screwdriver control, two multipin connectors (J2 and J3), and a coaxial connector are located on the front panel of the receiver. One of the multipin connectors has a wire plug inserted in it and a protective cap mounted over it. This protective cap and wired plug can be removed and the connector used to make electrical connection to a vhf communication transmitter. This connection permits use of the vhf navigation receiver as a vhf communication receiver.

c. Four shock mounts and an electrical connector are located on the top of the interconnecting box subassembly. The mounts and connector are used to provide mechanical and electrical connections to the power supply. Another multipin connector (J4), located at the rear of the interconnecting box subassembly, permits connection of the vhf navigation receiver to the rack.

d. Two frequency windows located on the right-hand side of the vhf navigation receiver provide a visual indication of the megacycle and fractional megacycle frequencies to which the circuits of the vhf navigation receiver are tuned. The front window provides visual access to fractional megacycle dial readings. The

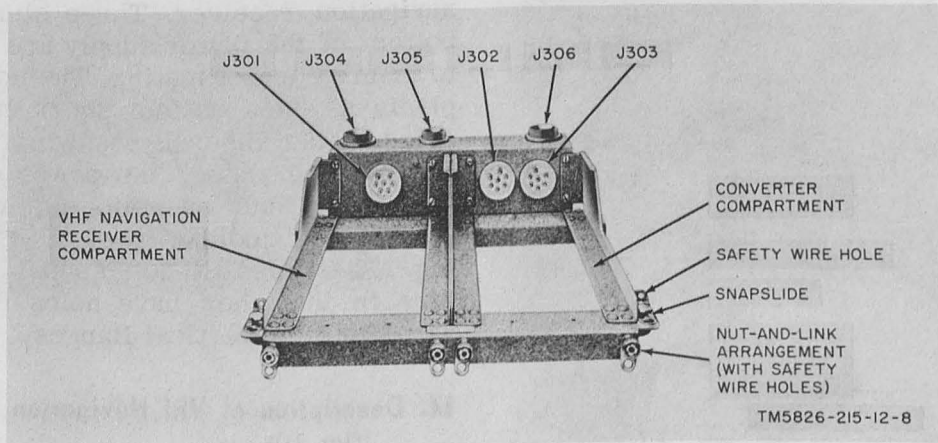

Figure 8. Rack.

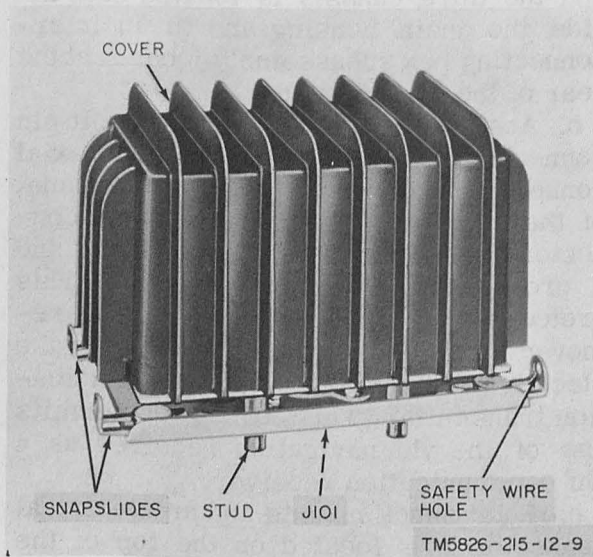

Figure 9. Power supply.

rear window provides visual access to megacycle dial readings. These windows are not viewable when the vhf navigation receiver is installed on the rack, unless the converter is removed from the rack.

## 15. Additional Equipment Required

The following equipments are not supplied with the vhf navigation set but are required for its use. The additional equipments are normally part of the aircraft wiring system.

*a. Coaxial Cable.* Radio Frequency Cable RG-58/U is required to connect the antenna to the vhf navigation receiver. It should be no longer than necessary.

*b. Coaxial Connectors.* Radio Frequency Plugs UG-88/U are required to terminate the ends of the coaxial cable between the antenna and vhf navigation receiver.

*c. Cable Harness Connectors.* Cable harness connectors (2 ARC Type 14050 or equivalent, 1 ARC Type 14320 or equivalent, and 1 ARC Type 15912 or equivalent) are required to terminate various ends of the cable harness between the rack, course indicator, and vhf navigation control unit.

*d. Cable Assembly Connectors.* Two cable assembly connectors (ARC Type 16115 or equivalent) are required to terminate the ends of the cable assembly between the vhf navigation receiver and the vhf navigation control unit.

*e. Power Cable Connector.* A power cable connector (ARC Type 14321 or equivalent) is required to terminate the power cable supplying low-voltage (lv) power to the rack.

*f. Cable Harness and Cable Assembly.* A cable harness and a cable assembly are required for interconnection between the various components of the vhf navigation set. They are fabricated from individual wires, which are not supplied with the vhf navigation set, and from the connectors described in *c* and *d* above. The wire

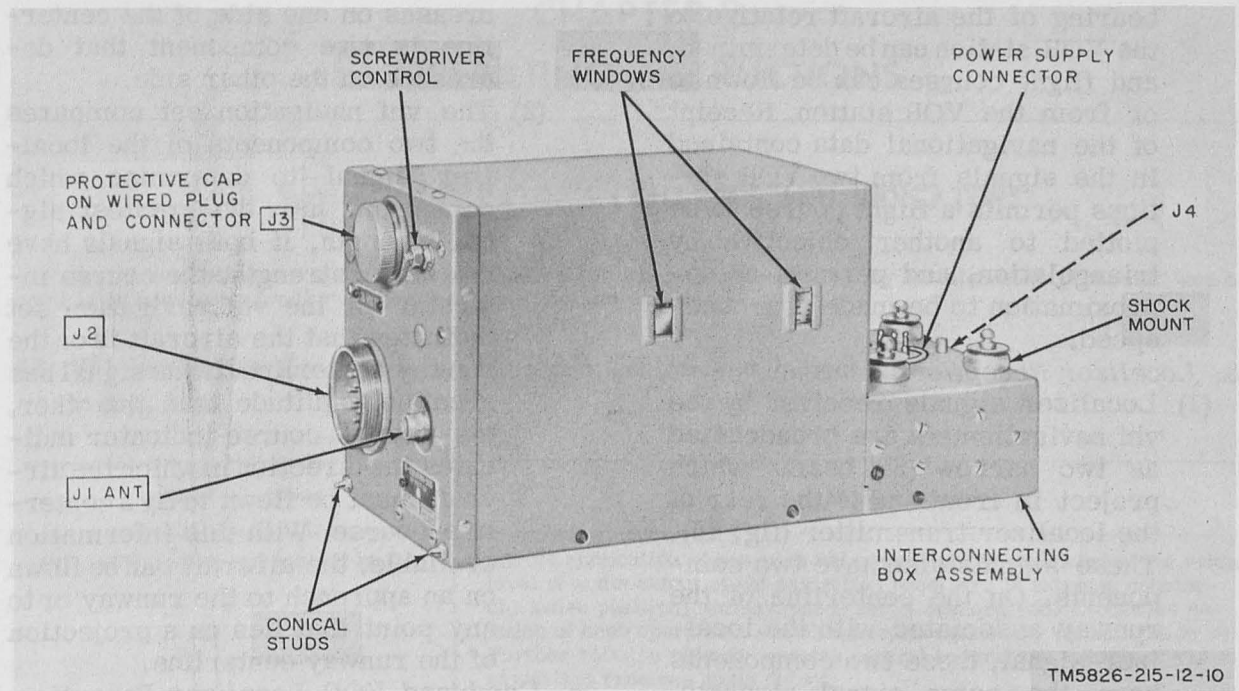

Figure 10. Vhf navigation receiver.

size varies with each installation. The actual length of the cable harness and cable assembly depends upon the location of the various components of the vhf navigation set in the aircraft. Refer to the appropriate aircraft technical manual.

g. *Aircraft Primary Power Source.* A 28-volt direct-current (dc) primary source capable of delivering 2.5 amperes is required to operate the vhf navigation set.

## 16. System Application

The vhf navigation set receives, interprets, and provides indication of aircraft navigational data contained in two types of vhf radio transmissions: VOR and localizer.

### a. VOR Reception.

(1) The VOR signals received by the vhf navigation set are broadcasted in all directions around a VOR station (fig. 13). These signals have two components. The first of these components has a phase which is the same in all directions of transmission. This phase is assigned a reference value of  $0^\circ$ . The

second component has a variable phase which changes with the direction of signal transmission. The difference between the phase of the two signal components is proportional at any given point to the angular difference between the magnetic north heading of the transmitter and the bearing of the transmitted signal at that point. For example, a signal received at a point that lies on the  $90^\circ$  bearing of the VOR station has a difference of  $90^\circ$  between its two signal components.

(2) The vhf navigation set compares the two components of the VOR signal to determine the difference between the phase of the variable component and the fixed (reference) component. This difference is displayed on the course indicator of the vhf navigation set as the magnetic bearing of the VOR station for the point at which the signal is received. With the magnetic bearing determined, the

bearing of the aircraft relative to the VOR station can be determined, and flight courses can be flown to or from the VOR station. Receipt of the navigational data contained in the signals from two VOR stations permits a flight course to be plotted to another objective by triangulation, and permits an approximation to be made of ground-speed.

*b. Localizer Reception.*

- (1) Localizer signals received by the vhf navigation set are broadcasted as two narrow (5°) beams which project in front and to the rear of the localizer transmitter (fig. 16). These signals also have two components. On the centerline of the runway associated with the localizer signal, these two components have the same signal strength. However, on each side of this centerline, the strength of one of the components increases, and the strength of the other component decreases. The component that in-

creases on one side of the centerline is the component that decreases on the other side.

- (2) The vhf navigation set compares the two components of the localizer signal to determine which component has the greatest signal strength. If both signals have the same strength, the course indicator in the vhf navigation set indicates that the aircraft is on the runway centerline. If one signal has greater amplitude than the other, the aircraft course indicator indicates the direction in which the aircraft must be flown to fly a centerline course. With this information available, the aircraft can be flown on an approach to the runway or to any point that lies on a projection of the runway centerline.

*c. Combined VOR-Localizer Reception.*

By alternately tuning to both the VOR and localizer signals, or by using two vhf navigation sets in the same aircraft, the aircraft can be flown to a point of intersection of the localizer and VOR signals.



# CHAPTER 2

## OPERATING INSTRUCTIONS

### Section I. OPERATOR'S CONTROLS AND INDICATORS

*Note.* This section covers only items used *by the operator*; items used by maintenance personnel are covered in instructions for the appropriate maintenance echelon.

#### 17. Vhf Navigation Control Unit, Operator's Control and Indicators (fig. 11)

Control or indicator	Function
VOL-OFF switch and control knob . . .	Controls application of power to vhf navigation set and determines volume level of audio output of vhf navigation receiver. In extreme counter-clockwise position, vhf navigation set is deenergized. Clockwise rotation of knob operates a switch which energizes the vhf navigation set. Further rotation of knob operates control to increase volume of vhf navigation receiver audio output.
SQUELCH control . . . . .	Controls signal level at which vhf navigation receiver squelch action occurs. Squelch action quiets vhf navigation receiver noise when no signal input is present. Clockwise rotation quiets vhf navigation receiver audio output.
Megacycle channel selector switch . . .	Selects frequency to which vhf navigation receiver is tuned. Frequency selection is in 1-mc steps, between 108 mc and 126 mc. Frequency selected is displayed on left-hand MC dial.
Fractional megacycle channel selector switch.	Selects fractional megacycle frequency to which vhf navigation receiver is tuned. Frequency selection is in 0.1-mc-steps, between 0.0 mc and 0.9 mc. Frequency selected is displayed on right-hand MC dial.
MC dials . . . . .	Indicates frequency to which vhf navigation receiver is tuned. Left-hand dial indicates frequency in megacycles in 1-mc steps between 108 and 126. It is positioned by megacycle channel selector switch. Right-hand dial indicates fractional frequency in 10th megacycles in 0.1-mc steps between 0.0 and 0.9. It is positioned by fractional megacycle channel selector switch.

#### 18. Course Indicator, Operator's Controls and Indicators (fig. 12)

Control or indicator	Function
Course selector knob . . . . .	Selects desired magnetic bearing of aircraft, relative to VOR station being received. Its setting is indicated by position of course pointer on the selector dial. Aircraft is at bearing selected when vertical pointer is centered.
Course pointer . . . . .	Indicates magnetic bearing selected by operation of course selector knob. When vertical pointer is centered, aircraft is flying magnetic bearing indicated by course pointer.
Reciprocal pointer . . . . .	Indicates the magnetic bearing which is 180° out of phase with bearing selected by positioning of course selector knob.
OFF vertical flag . . . . .	Indicates that vhf navigation receiver is tuned to VOR or localizer station frequency of usable signal strength by moving out of view.
OFF horizontal flag . . . . .	Indicates proper reception of glide-slope signals (when course indicator is used with glide-slope navigation equipment) by moving out of view.
TO-FROM meter . . . . .	Indicates TO when aircraft is flying towards VOR station being received; indicates FROM when aircraft is flying away from VOR station being received.

Control or indicator	Function
Vertical pointer .....	Indicates whether or not aircraft is flying on selected course. Vertical pointer is centered (selector dial reading of 18) in VOR operation when aircraft is flying magnetic bearing indicated by position of course pointer. Vertical pointer is centered in localizer operation when the aircraft is flying on the runway centerline.
Horizontal pointer .....	

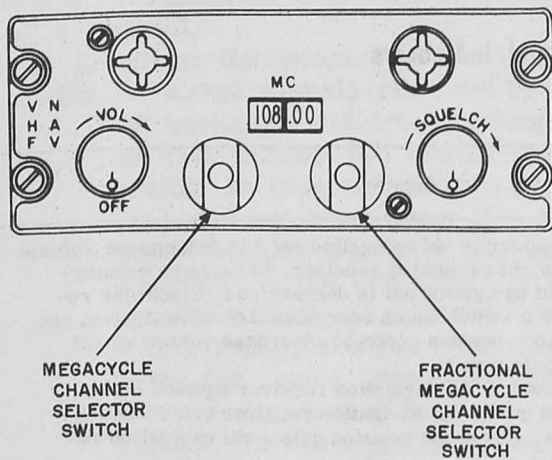

TM 5826-215-12-11

Figure 11. Vhf navigation control unit, operator's controls and indicators.

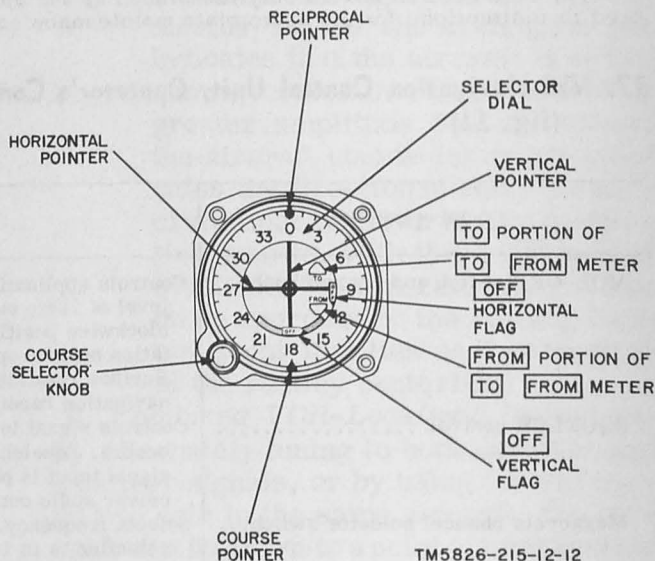

TM 5826-215-12-12

Figure 12. Course indicator, operator's controls and indicators.

## Section II. OPERATION UNDER USUAL CONDITIONS

### 19. Types of Operation

a. The vhf navigation set can be operated with either VOR or localizer stations to perform a number of navigational procedures. The vhf navigation set can also be operated, in part, as communication receiving equipment. During VOR navigational procedures, the vhf navigation set is tuned to an even-numbered, 10th-megacycle frequency between 108.2 mc and 112.0 mc or to either an odd- or even-numbered, 10th-megacycle frequency between 112.1 mc and 117.9 mc. During localizer procedures, the vhf navigation set is tuned to odd-numbered, 10th-megacycle frequencies between 108.1 mc and 111.9 mc. During procedures that use the vhf navigation set as communication receiving equipment, the set is tuned to any

frequency between 108.0 mc and 126.9 mc that corresponds to the operating frequency of an in-range vhf transmitter.

b. During VOR operation, the navigational procedures are used to:

- (1) Determine aircraft bearing relative to a VOR station (para 22).
- (2) Fly a course to or from a VOR station (para 23).
- (3) Make a VOR approach (para 24).
- (4) Fly to an objective other than a VOR station (para 25).
- (5) Make an approximate ground-speed check (para 26).

c. During localizer operation, the navigational procedures are used to:

- (1) Make a front course approach (para 27).
- (2) Make a back course approach (para 28).

d. Localizer and VOR operation can be combined to fly a course to the intersection of the beam transmitted by a localizer station using a specific VOR station bearing (para 29).

e. Use of the vhf navigation set as communication equipment allows the operator to:

- (1) Receive any in-range vhf transmitter station output at a frequency to which the set can be tuned.
- (2) Supply B+ power to a vhf transmitter operating in conjunction with the vhf navigation set.

f. To operate the vhf navigation set for any particular type of operation, perform the following:

- (1) Starting procedure (para 21).
- (2) Procedure for the type of operation desired (para 22 through 30).
- (3) Stopping procedure (para 31).

## 20. Operating Limitations

Performance of the procedures listed in paragraph 19 is limited by the characteristics of vhf transmission. These limitations (a-d below) are usually temporary.

a. *Reception of Reflected Radio Waves.* Vhf radio waves are reflected when they strike an object the conductivity and dielectric constant of which are different from the atmosphere through which they are moving. When reflection occurs, the combined effect of the direct and reflected wave produces a pattern of alternate lobes of reinforced and cancelled waves in the area above the reflecting surface. Radio reception may be subject to fading as the aircraft passes through this area. When fading occurs, the vertical pointer may fluctuate considerably and the OFF vertical flag may show intermittently.

b. *Shadow Effect.* Large obstacles can produce a shadow area on the side away from the transmitting antenna in which reception is very poor or nonexistent. This effect can be overcome by increasing altitude.

c. *Duct Effect.* Trapping of vhf radio waves in atmospheric ducts frequently extends the range of transmitted waves

several times over their normal usable range. This effect can cause a station normally out of range to interfere with the reception of a desired in-range station. Although ducts can extend for miles, a pilot can usually fly out of them since the ducts are frequently shallow.

d. *Usable Transmission Distances.* In vhf transmission, the radiated waves generally travel in an approximately straight line. Therefore, the maximum usable transmission distance depends on the location of the transmitting and receiving antennas. The following chart gives the approximate line-of-sight transmission range for various aircraft altitudes.

Aircraft altitude (ft)	Approximate transmission range (nautical miles)
100	12
200	15
400	25
600	30
800	35
1,000	40
2,000	50
3,000	65
4,000	70
5,000	80
8,500	100
10,000	115
12,500	125
15,000	135
17,500	145
20,000	160

## 21. Starting Procedure

a. Before operating the vhf navigation set, certain controls must be operated which are unique to the particular aircraft in which the equipment is installed. For the application of primary power or the connection of the vhf navigation set audio circuits to the interphone system of the aircraft, these controls may include a radio or communications master power switch, a push-to-reset circuit breaker button, or an intercommunication switch. For proper operation of these controls, refer to the applicable aircraft technical manual.

b. Rotate the SQUELCH control on the vhf navigation control unit (fig. 11) to the extreme counterclockwise position.

c. Operate the VOL-OFF switch and

control knob on the vhf navigation control unit clockwise until a click is heard, indicating that the vhf navigation set is energized.

d. Allow 5 minutes for the vhf navigation set to warm up.

e. Operate the megacycle channel selector switch and/or the fractional megacycle channel selector switch on the vhf navigation control unit so that the MC dials indicate the frequency of an in-range VOR transmitter. Refer to the aeronautical chart used during the flight for the frequency and location of the in-range VOR transmitter.

f. Turn the VOL-OFF switch and control knob on the vhf navigation control unit clockwise until the dot-dash code or voice signal for the station to which the vhf navigation set was tuned (e above) is at the desired volume.

*Note.* In some aircraft, the VOL-OFF switch and control knob on the vhf navigation set is operated to the maximum clockwise position. The amount of audio output from the vhf navigation set to the interphone system of the aircraft is then determined by a control in the interphone system itself. For proper operation of these controls, refer to the applicable aircraft technical manual.

**Warning:** The OFF vertical flag of the course indicator is an indication of signal strength and reliability. If the OFF vertical flag does not go out of view or if it fluctuates, it is an indication that the signal received is not of sufficient strength to be reliable or the vhf navigation set is not functioning properly. Under no circumstances should navigation be attempted with the vhf navigation set if the OFF vertical flag is visible.

g. Check the course indicator (fig. 12) to insure that the OFF vertical flag is out of sight.

h. Operate the megacycle channel selector switch and/or the fractional megacycle channel selector switch on the vhf navigation control unit (fig. 11) so that the MC dials indicate a frequency to which no in-range VOR or localizer station assignment is made. If duct effect (para 20c) is experienced, choose another unassigned or out-of-range frequency.

i. Rotate the SQUELCH control on the vhf navigation control unit (fig. 11) clockwise until the vhf navigation receiver noise output is at the level desired with the aircraft engines and all electrical equipment operating normally.

j. Operate the megacycle channel selector switch and/or the fractional megacycle channel selector switch on the vhf navigation control unit back to the settings established in e above. The station call sign should be heard; if not, back off the SQUELCH control on the vhf navigation control unit (fig. 11) counterclockwise until reception is at a satisfactory level.

## 22. Determining Aircraft Bearing Relative to VOR Station

a. Perform the starting procedure given in paragraph 21.

b. Set the megacycle channel selector switch and fractional megacycle channel selector switch on the vhf navigation control unit (fig. 11) to the positions that cause the MC dials to indicate the frequency of the VOR station relative to which the aircraft bearing is to be determined.

c. Listen for the station call sign. Adjust the audio level to the aircraft intercommunication system if necessary (para 21f). Note the identifying signal to be sure that the proper station is tuned in. Be sure that the OFF vertical flag (fig. 12) is out of sight on the course indicator and that the TO-FROM meter is indicating either TO or FROM.

**Warning:** Do not use the vhf navigation set for navigational purposes if the OFF vertical flag on the course indicator (fig. 12) is visible or if the TO-FROM meter does not indicate.

d. Rotate the course selector knob on the course indicator (fig. 12) until the vertical pointer is centered (selector dial setting 18).

e. Read the course selector bearing to which the course pointer is pointing and note whether it is TO or FROM. This is the bearing of the aircraft relative to the VOR station being received.

*Note.* The TO-FROM meter will indicate TO when the course pointer is set to a course that is toward the VOR station, and FROM when the course pointer is set to a reciprocal heading. The general location of the aircraft with respect to the VOR station may be determined as follows: If the course indicator shows  $135^{\circ}$  TO, the aircraft is *northwest* of the VOR station; if the indicator shows  $135^{\circ}$  FROM, the aircraft is *southeast* of the VOR station.

### 23. Flying Course to or from VOR Station

a. Perform the starting procedure given in paragraph 21.

b. Set the megacycle channel selector switch and/or fractional megacycle channel selector switch on the vhf navigation control unit (fig. 11) to the positions that cause the MC dials to indicate the frequency of the VOR station to which, or from which, the aircraft is to be flown.

c. Listen for the station call sign. Adjust the audio level to the aircraft intercommunication system if necessary (para 21f). Note the identifying signal to be sure that the proper station is tuned in. Be sure that the OFF vertical flag (fig. 12) is out of sight on the course indicator and that the TO-FROM meter is indicating either TO or FROM.

**Warning:** Do not use the vhf navigation set to fly to or from the VOR station if the OFF vertical flag on the course indicator (fig. 12) is visible, or if the TO-FROM meter does not indicate.

d. Rotate the course selector knob on the course indicator (fig. 12) until the course pointer points to the desired course to or from the VOR station. Figure 13 shows six aircraft with a selected course of  $90^{\circ}$ .

*Note.* In the following step, if the course chosen is in the general direction of the VOR station and the aircraft is less than approximately  $70^{\circ}$  from the selected course, the TO-FROM meter indicates TO as shown by aircraft A, B, and C. If the course chosen is in the general direction away from the VOR station and the aircraft is less than approximately  $70^{\circ}$  from the selected course, the TO-FROM meter indicates FROM as shown by aircraft D, E, and F. If the course chosen is in either direction relative to the VOR station, but is in the vicinity of  $90^{\circ}$  from the selected course, the TO-FROM meter indicates neutral (no indication is visible). In the latter case, it is necessary to visually determine aircraft position with respect to the desired course.

e. See that the TO-FROM meter on the course indicator has the required reading for the desired direction of flight.

f. Turn the aircraft until its magnetic heading is the same as the bearing established on the course indicator (c above) if a definite TO or FROM indication is seen on the TO-FROM meter.

g. Observe the position of the vertical pointer on the course indicator (fig. 12).

**Warning:** VOR operation supplies only position information. Direction or heading information must still be obtained from the magnetic compass. The rule of *flying toward the pointer* in the following step is applicable only if the course indicator bearing, the compass heading, and the desired course are the same.

h. Position the aircraft on the desired course by *flying toward the pointer* on the course indicator; that is, if the vertical pointer is left of center (in the blue area), fly a heading somewhat to the left (as illustrated by aircraft C and F) and hold the chosen heading until just prior to reaching the desired course; if the pointer is right of center (in the yellow area), fly a heading somewhat to the right (as illustrated by aircraft A and D) and hold the chosen course until just prior to reaching the desired course. Do not make excessive heading changes to keep the vertical pointer centered. Fly the general trend of the vertical pointer to prevent overcorrecting.

*Note.* In the following step, the initial intercept angle depends on the displacement from the desired course. If far off-course (the vertical pointer is hard over), an initial intercept angle up to  $90^{\circ}$  can be chosen. If only slightly off-course, intercept angles of only  $5^{\circ}$  to  $10^{\circ}$  are required. When the vertical pointer is centered, the aircraft is on the selected course (as shown by aircraft A and E). Attempt to keep the vertical pointer directly in the center. If the vertical pointer fluctuates, fly the general trend of the vertical pointer to prevent overcorrection. If the aircraft compass heading and the course indicator bearing are about  $180^{\circ}$  apart, it indicates that the aircraft is heading in a direction opposite to the desired course. An attempt to *fly toward the pointer* under this condition causes the pointer to move still further left or right. To correct the situation, make a  $180^{\circ}$  turn and then *fly toward the pointer*.

i. Reduce the intercept angle of the aircraft as the desired course is approached to prevent overshooting the course.

j. Maintain the desired course when reached.

## 24. Making VOR Approach

**Warning:** Approaches that use a VOR station must be authorized and performed in accordance with published information.

a. Perform the starting procedure given in paragraph 21.



b. Fly a desired course to the VOR station (para 23).

c. Watch for the following indications that the aircraft has arrived over the VOR station:

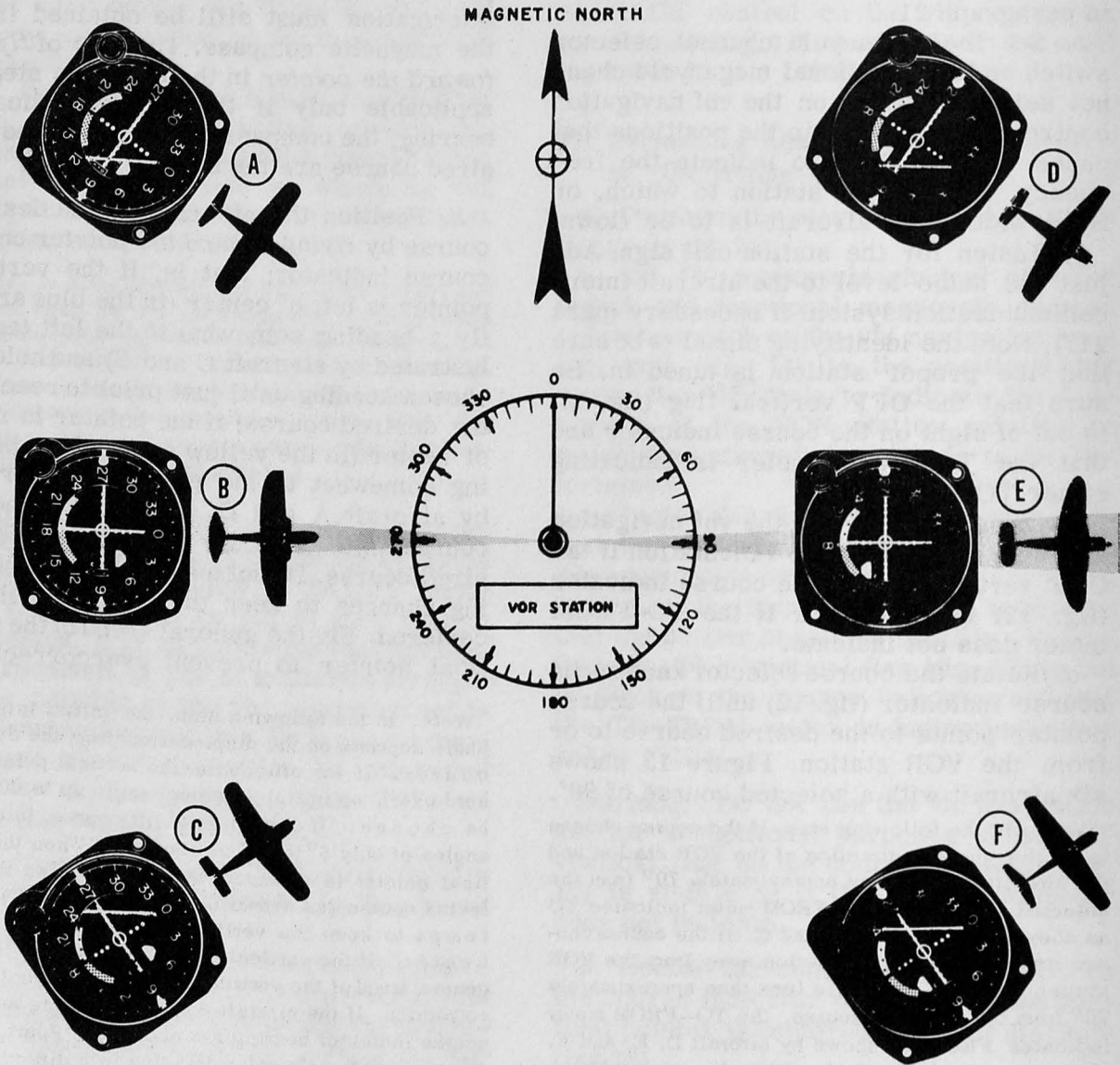
(1) The signal heard on the aircraft intercommunication system increases in volume and may be distorted.



**NOTE**

-  INDICATES BLUE
-  INDICATES YELLOW

TM5826-25-12-13

Figure 13. Flying to or from VOR station.

- (2) The vertical pointer on the course indicator (fig. 12) swings abruptly from side to side.
- (3) The OFF vertical flag may appear and disappear in rapid succession.
- d. Let down in accordance with the instructions published for the VOR station in question.

## 25. Flying to Objective Other Than VOR Station

a. Perform the starting procedure given in paragraph 21.

b. Determine the magnetic bearing of the objective from the two VOR stations closest to the objective, by referring to the appropriate navigation map. (In an example shown in figure 14, the objective lies 30° magnetic from VOR station X and 330° magnetic from VOR station Y, and the aircraft is near VOR station X at the start of the procedure.)

c. Fly the appropriate course to or from one of the VOR stations (30° from station X, in the example), by following the same instructions provided to fly a desired course to or from a VOR station (para 23).

d. Check the vertical pointer on the course indicator (fig. 12) frequently in order to stay on course (A, fig. 14).

*Note.* The time at which station Y is tuned in the following steps depends on the distances between the objective and the VOR stations. Remain tuned to station X as long as possible. If the aircraft is equipped with two vhf navigation sets, use the second set to perform steps e and f below.

e. Operate the megacycle channel selector switch and/or the fractional megacycle channel selector switch on the vhf navigation control unit (fig. 11) so that the frequency of station Y appears on MC dials, before the bearing of VOR station Y (330° in the example) is reached.

f. Listen for the station call sign. Adjust the audio level to the aircraft intercommunication system if necessary (para 21f). Note the identifying signal to be sure that the proper station is tuned in. Be sure that the OFF vertical flag (fig. 12) is out of sight on the course indicator and the TO-FROM meter is indicating either TO or FROM.

g. Rotate the course selector knob on the

course indicator (fig. 12) so that the course pointer is pointed to the VOR station Y bearing (33 for a 330° bearing in B, fig. 14). The vertical pointer will swing towards the side of the course indicator on which the VOR station is located.

h. Use the directional gyro of the aircraft (or the first vhf navigation set) to maintain the course from station A (30°).

i. Observe the vertical pointer on the course indicator (fig. 12) of the vhf navigation set tuned to VOR station Y. When it centers, the aircraft is over the chosen objective (C, fig. 14).

## 26. Making Approximate Groundspeed Checks

a. Perform the starting procedure given in paragraph 21.

b. Chart a desired course of flight. (In an example shown in figure 15, a course has been selected that lies on a 30° bearing from VOR station X.)

c. Set and fly the desired course in accordance with the instructions of paragraph 23. A of figure 15 shows the course selector knob adjusted so that the course pointer lies at the dial reading of 3 (corresponding to 30°), the TO-FROM meter reads FROM, and the vertical pointer is centered. The aircraft heading indicated on the magnetic compass may differ from the desired course (30° in the example) if there is a headwind; however, adjust the heading to keep the vertical pointer centered.

d. Operate the megacycle channel selector switch and the fractional megacycle channel selector switch on the vhf navigation control unit (fig. 11) so that the frequency of a second in-range VOR station is shown on the MC dials. If the aircraft has two vhf navigation sets, use the second set to tune the second VOR station.

e. Listen for the station call sign. Adjust the audio level to the aircraft intercommunication system if necessary (para 21f). Note the identifying signal to be sure that the proper station is tuned in. Be sure that the OFF vertical flag (fig. 12) is out of sight on the course indicator and that the TO-FROM meter is indicating either TO or FROM.

f. Determine the bearing of the second

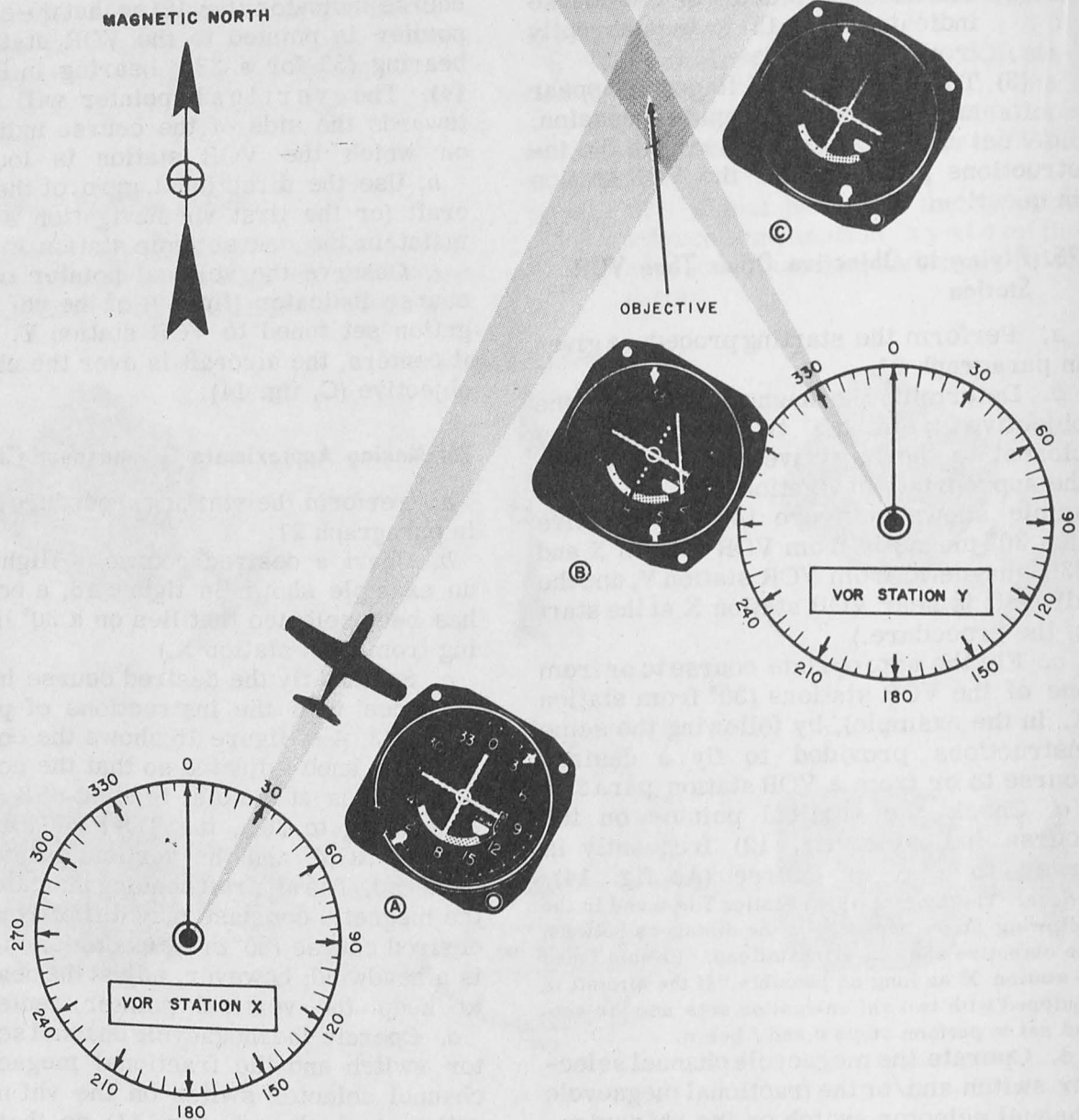

**NOTE**



INDICATES BLUE  
INDICATES YELLOW

TM5 826 - 215 - 12 - 15

Figure 14. Flying to objective other than VOR station.

VOR station (para 22). (B, figure 15, shows that the second station (Y) is on a 270° bearing.) Mark this position on the aeronautical chart used for the flight.

g. Make note of the time and maintain the course flown in c above.

h. Determine the bearing of the second VOR station (para 22) again, at the end of

a selected period of time (0.2 hour for example). (C, figure 15, shows that the second station (Y) is on a 330° bearing.) Mark this position on the aeronautical chart.

i. Measure the distance (D) on the aeronautical chart between the two positions at which the bearings of the second VOR



station were determined. (In figure 15, the distance is 32 miles.)

j. Compute the approximate ground-speed by dividing the distance measured (*i* above) by the time selected (*h* above). In the example shown:

$$\frac{\text{Distance}}{\text{Time}} = \frac{32 \text{ miles}}{0.2 \text{ hour}} = 160 \text{ mph.}$$

## 27. Making Front Course Localizer Approaches

a. Perform the starting procedure given in paragraph 21.

**Warning:** Do not proceed if the OFF vertical flag on the indicator (fig. 12) can be seen after the next step is performed.

b. Operate the megacycle channel selector switch and/or the fractional megacycle channel selector switch on the vhf navigation control unit (fig. 11) to indicate a frequency on the MC dials that corresponds to the frequency of the localizer station to be approached.

c. Listen for the station call sign. Adjust the audio level to the aircraft intercommunication system if necessary (para 21f). Note the identifying signal to be sure that the proper station is tuned in. Be sure that the OFF vertical flag (fig. 12) is out of sight on the course indicator.

d. Perform the preliminary flight procedures which are specified by the published information for the approach being made.

e. Check the position of the vertical pointer on the course indicator (fig. 12) and begin flying toward the localizer station.

f. Fly left if the vertical pointer on the course indicator is left of center (blue area on the dial) (A, fig. 16) and a 150-cycle-per-second (cps) tone is heard on the aircraft intercommunication system (when used); fly right if the vertical pointer is right of center (yellow area on the dial) (B, fig. 16) and a 90-cps tone is heard on the aircraft intercommunication system (when used). Make relatively small changes in heading. Small deviations (2.5°) from the center of the localizer beam produce full-scale deflection of the vertical pointer.

g. Maintain the course that keeps the vertical pointer centered in order to make the approach (C, fig. 16).

## 28. Making Back Course Localizer Approaches

a. Perform the starting procedure given in paragraph 21.

**Warning:** Do not proceed if the OFF vertical flag on the course indicator can be seen after the following step is performed.

b. Operate the megacycle channel selector switch and/or the fractional megacycle channel selector switch on the vhf navigation control unit (fig. 11) to indicate a frequency that corresponds to the frequency of the localizer station to be approached.

c. Perform the preliminary flight procedures which are specified by the published information for the approach being made.

d. Check the position of the vertical pointer on the course indicator (fig. 12) and begin flying toward the localizer station.

**Note.** The indications in the following step are the opposite of the indications in a front course localizer approach (para 27).

e. Fly left if the vertical pointer on the course indicator is right of center (yellow area of the dial) (A, fig. 17) and a 90-cps tone is heard on the aircraft intercommunication system (when used); fly right if the vertical pointer is left of center (blue area of the dial) (B, fig. 17) and a 150-cps tone is heard on the aircraft intercommunication system (when used).

f. Maintain the course that keeps the vertical pointer on the course indicator (fig. 12) centered (C, fig. 17) to make the back approach.

## 29. Intersecting Localizer Signal Using VOR Station

a. Perform the starting procedure given in paragraph 21.

b. Determine the magnetic bearing of the desired point of intersect of the localizer beam and the VOR station by referring

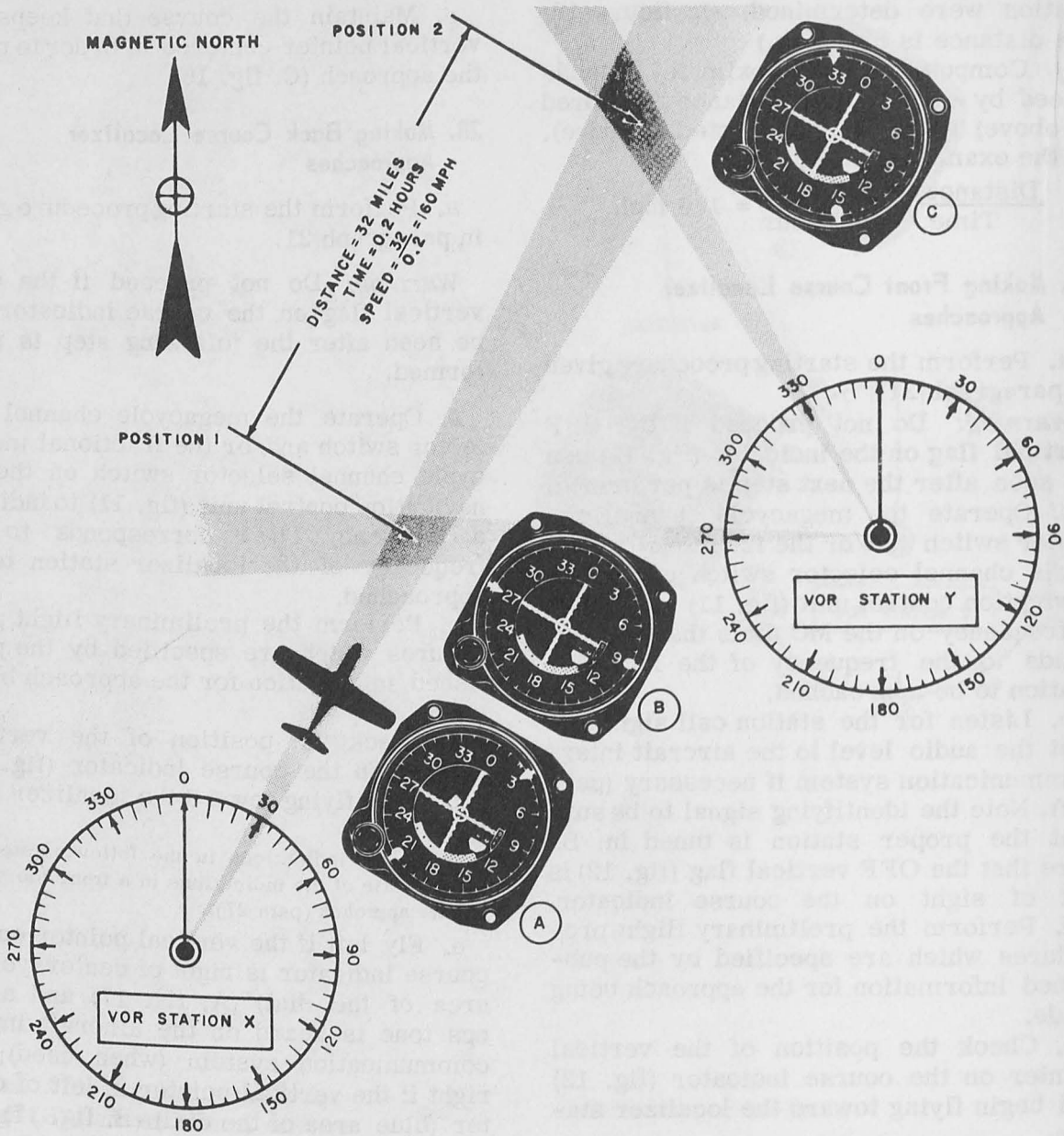

**NOTE**

- INDICATES BLUE
- INDICATES YELLOW

TM5826 -215 -12 -16

Figure 15. Making approximate groundspeed check.



to the appropriate navigation map. (Figure 18 shows an example in which the desired point of intersect of a localizer lies 60° magnetic from the VOR station and the aircraft is southwest of the VOR station.)

*Note.* If, in the following step, it is necessary to fly over a VOR station, the following indications are observed: The signal heard over the aircraft inter-

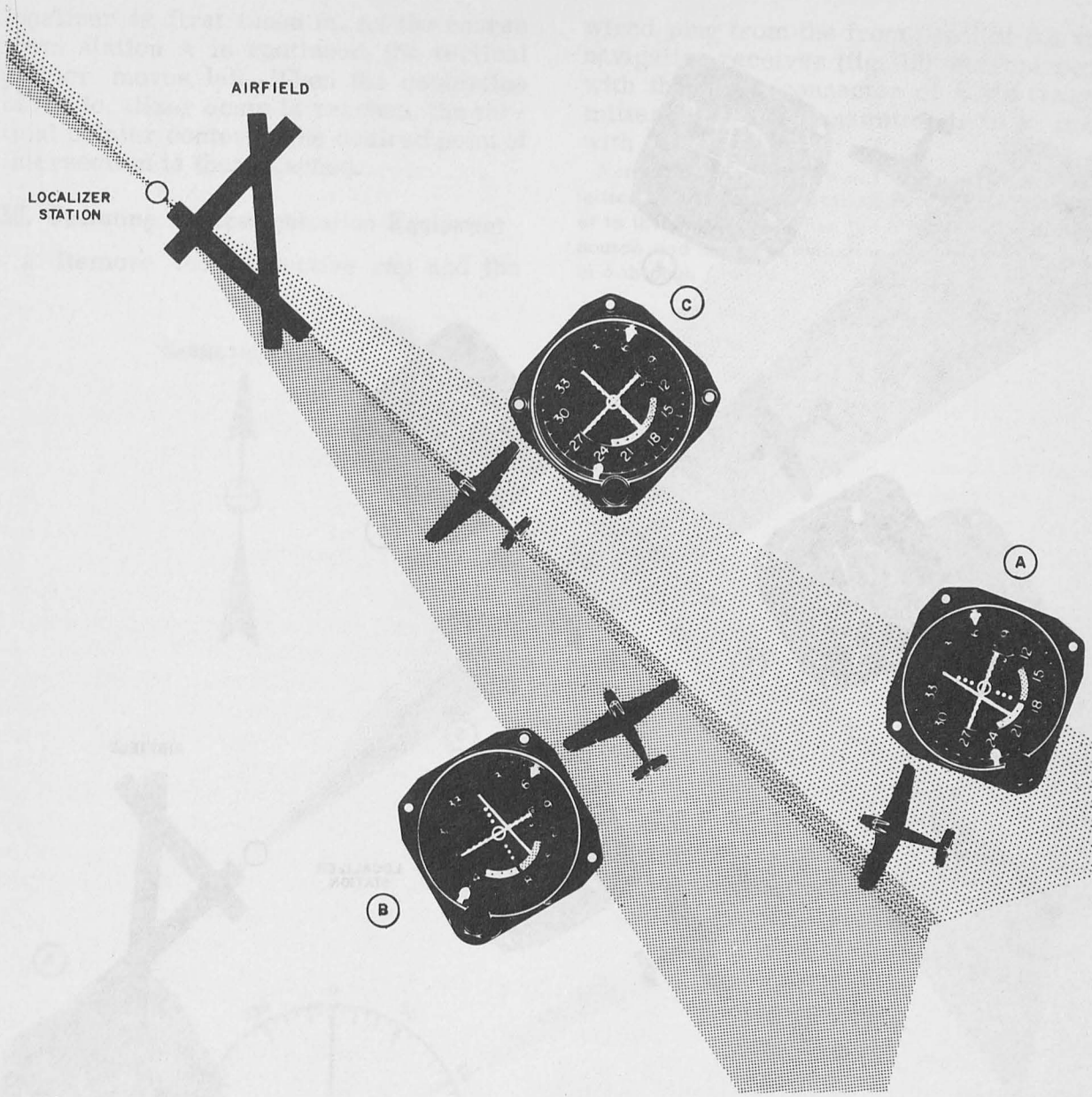
communication system suddenly increases in strength and may be distorted; the vertical pointer on the course indicator (fig. 12) swings abruptly from side to side; the OFF vertical flag on the indicator appears and disappears in rapid succession; the TO-FROM meter on the course indicator indicates erratically, fluctuating between TO and FROM, and finally steadying into the FROM position as the aircraft passes over the VOR station.



**NOTES:**

1.  INDICATES BLUE
2.  INDICATES YELLOW
3. COURSE POINTER POSITION DOES NOT AFFECT VERTICAL POINTER DEFLECTION DURING LOCALIZER OPERATION.

TM5826-215-12-17



Figure 16. Making front course localizer approach.

c. Set and fly the course that corresponds to the bearing of the intersect point relative to the VOR station (para 23). (In the example chosen, this course would be on a 60° bearing TO (A, fig. 18) over, and then FROM (B, fig. 18) the VOR station.)

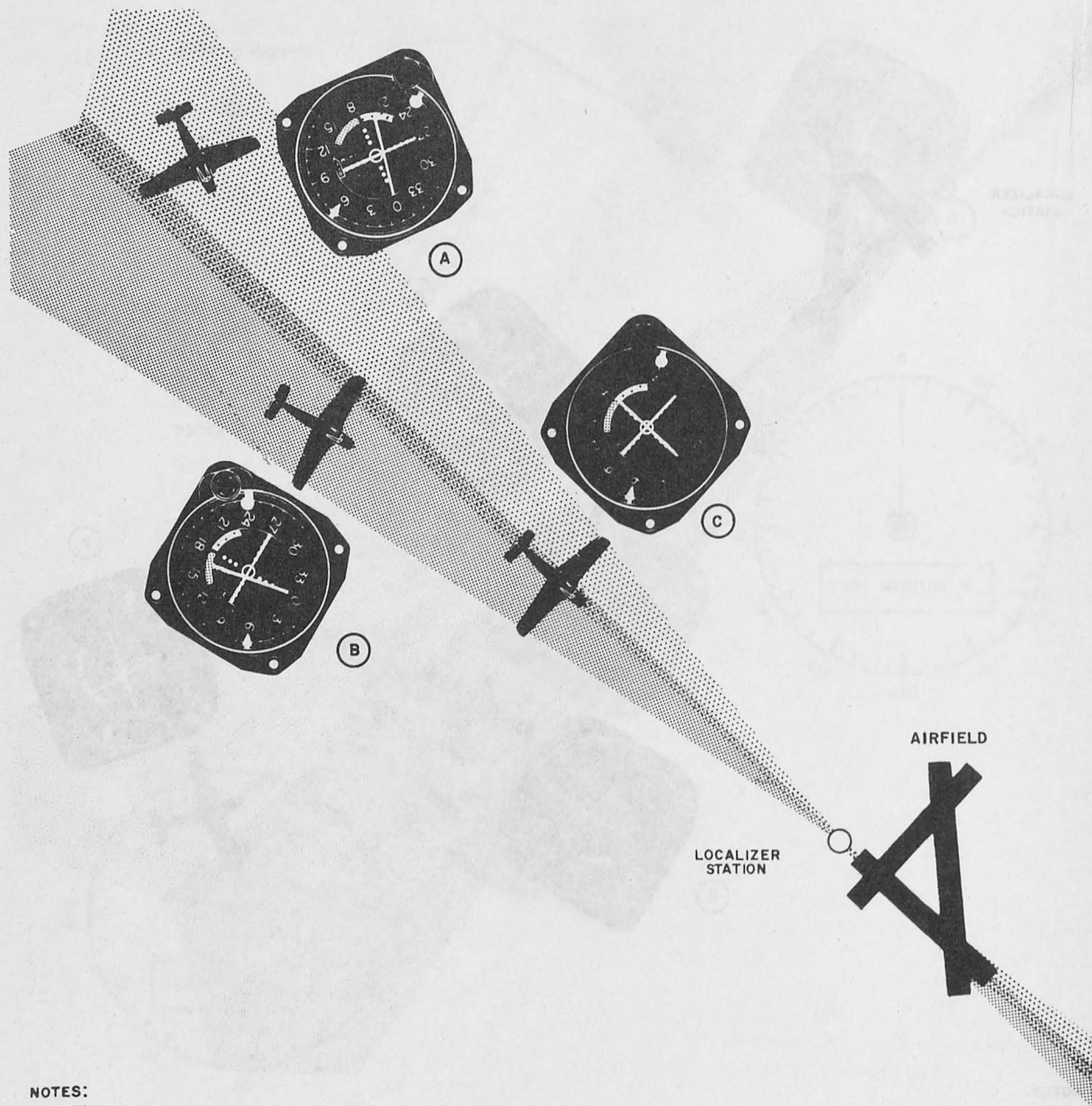
d. Operate the megacycle channel selector switch and/or the fractional megacycle channel selector switch on the vhf navigation control unit (fig. 11) as the localizer station radio beam is approached so that the frequency of the localizer



NOTES:

1.  INDICATES BLUE
2.  INDICATES YELLOW
3. COURSE POINTER POSITION DOES NOT AFFECT VERTICAL POINTER DEFLECTION DURING LOCALIZER OPERATION.

TM5826-215-12-19

Figure 17. Making back course localizer approach.

station appears on the MC dials.

e. Listen for the station call sign. Adjust the audio level to the aircraft intercommunication system if necessary (para 21f). Note the identifying signal to be sure that the proper station is tuned in. Be sure

that the OFF vertical flag (fig. 12) is out of sight on the course indicator.

f. Observe the vertical pointer on the course indicator (fig. 12). The vertical pointer indicates in the yellow area of the vertical pointer dial (C, fig. 18) when the

localizer is first tuned in. As the course from station A is continued, the vertical pointer moves left. When the centerline of the localizer beam is reached, the vertical pointer centers. The desired point of intersection is then reached.

### 30. Operating as Communication Equipment

a. Remove the protective cap and the

wired plug from the front panel of the vhf navigation receiver (fig. 10) and replace it with the cable connector of a vhf transmitter, if a vhf transmitter is to be used with the set.

*Note.* Connection of a vhf communication transmitter as in *a* above automatically applies B+ power to the transmitter when the aircraft 28-volt input source and the vhf navigation set are energized as in *b* through *f* below.

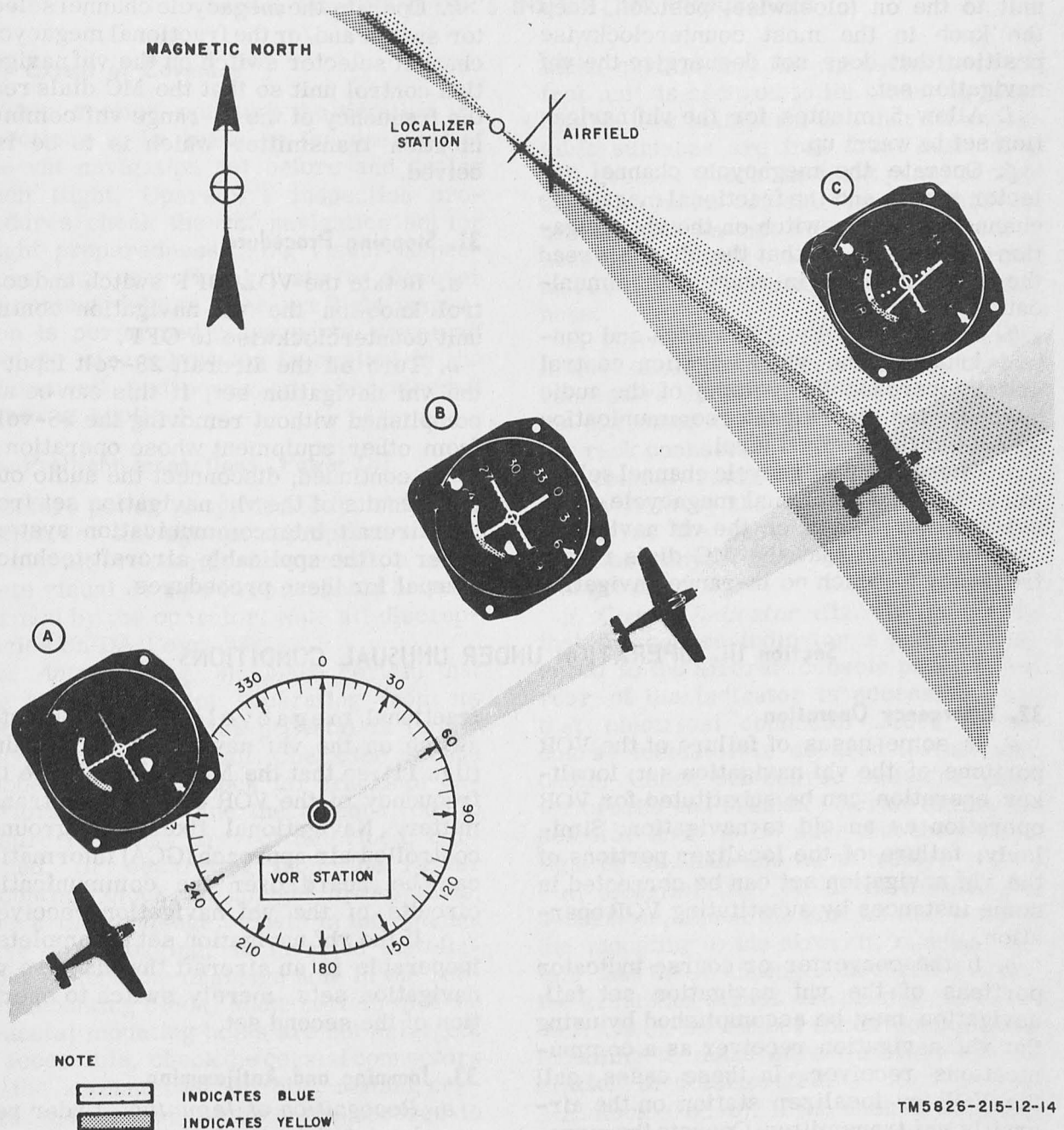

TM5826-215-12-14

Figure 18. Intersecting a localizer course.

b. Turn on the aircraft 28-volt input source to the vhf navigation set, if it is not already on. Refer to paragraph 21a.

c. Allow approximately 3 minutes for warmup.

d. Operate the SQUELCH control on the vhf navigation control unit (fig. 11) to the extreme counterclockwise position.

e. Turn the VOL-OFF switch and control knob on the vhf navigation control unit to the on (clockwise) position. Keep the knob in the most counterclockwise position that does not deenergize the vhf navigation set.

f. Allow 5 minutes for the vhf navigation set to warm up.

g. Operate the megacycle channel selector switch and the fractional megacycle channel selector switch on the vhf navigation control unit so that the MC dials read the frequency of an in-range vhf communication transmitter.

h. Turn the VOL-OFF switch and control knob on the vhf navigation control unit to increase the volume of the audio heard on the aircraft intercommunication system to the desired level.

i. Operate the megacycle channel selector and/or the fractional megacycle channel selector switch on the vhf navigation control unit so that the MC dials read a frequency to which no in-range navigation

or communication station assignment is made. If duct effect (para 20c) is experienced, choose another unassigned or out-of-range frequency.

j. Turn the SQUELCH control on the vhf navigation control unit clockwise until the vhf navigation receiver noise output is at the level desired with the aircraft engines and all electrical equipment operating normally.

k. Operate the megacycle channel selector switch and/or the fractional megacycle channel selector switch on the vhf navigation control unit so that the MC dials read the frequency of the in-range vhf communication transmitter which is to be received.

### 31. Stopping Procedure

a. Rotate the VOL-OFF switch and control knob on the vhf navigation control unit counterclockwise to OFF.

b. Turn off the aircraft 28-volt input to the vhf navigation set, if this can be accomplished without removing the 28-volts from other equipment whose operation is to be continued; disconnect the audio output circuits of the vhf navigation set from the aircraft intercommunication system. Refer to the applicable aircraft technical manual for these procedures.

## Section III. OPERATION UNDER UNUSUAL CONDITIONS

### 32. Emergency Operation

a. In some cases of failure of the VOR portions of the vhf navigation set, localizer operation can be substituted for VOR operation as an aid to navigation. Similarly, failure of the localizer portions of the vhf navigation set can be corrected in some instances by substituting VOR operation.

b. If the converter or course indicator portions of the vhf navigation set fail, navigation may be accomplished by using the vhf navigation receiver as a communications receiver. In these cases, call the VOR or localizer station on the aircraft's vhf transmitter. Operate the megacycle channel selector switch and/or the

fractional megacycle channel selector switch on the vhf navigation control unit (fig. 11) so that the MC dials indicate the frequency of the VOR or localizer transmitter. Navigational fixes and ground-controlled air approach (GCA) information can be heard over the communication circuits of the vhf navigation receiver.

c. If the vhf navigation set is completely inoperable in an aircraft that has two vhf navigation sets, merely switch to operation of the second set.

### 33. Jamming and Antijamming

a. *Recognition of Jamming.* Under real or simulated tactical conditions, the receiver is likely to be jammed by the enemy.

Jamming may be performed by transmitting a strong signal on the VOR or localizer frequencies, thereby making it difficult or impossible to hear the desired signals. Unusual noise or strong interference may also be caused by the enemy.

*b. Antijamming Procedures.* When the

vhf navigation set is being jammed, or reception is disturbed by interference, reception may be improved by increasing the clockwise rotation of VOL-OFF switch and control knob on the vhf navigation control unit (fig. 11). In some cases, tuning to a different ground station may improve reception.

## Section IV. OPERATOR'S INSPECTION PROCEDURE

### 34. Extent of Coverage

This section contains the detailed inspections to be made by the operator of the vhf navigation set before and during each flight. Operator's inspection procedures check the vhf navigation set for flight preparedness using visual inspections and operational tests to discover equipment defects. The preflight inspection is performed in two parts: power off (before aircraft power is applied to the equipment) and power on (after aircraft power is applied).

### 35. Preflight Inspections, Power Off

Before power is applied to the vhf navigation set through the appropriate switch or circuit breaker in the aircraft, a complete visual inspection should be performed by the operator. Note all discrepancies on DA Form 2391-2.

*a. Antenna* (fig. 3). Make certain that the antenna is not separating from its pedestal and that the pedestal is firmly secured to the aircraft. Check the antenna rubber mounting block for cracks or deterioration. Examine the antenna rods to insure that they are not deformed, corroded, or separating from the rubber mounting block. In upright installations, check the drainage tunnels in the antenna base for clogging; in inverted installations, check the drainage hole in the rubber mounting block. Make certain that the pedestal mounting holes are not enlarged. If accessible, check the coaxial connectors at the antenna base for dirt, making certain that the connectors are secured to the base.

*b. Vhf Navigation Control Unit* (fig. 4).

Make certain that the vhf navigation control unit is secured to its mounting panel by the lock fasteners. See that all accessible surfaces are free from dust, dirt, and grease. Check the front panel control knobs to make certain that they are not broken and do not bind when turned. If accessible, check electrical connectors J1 and J2 on the rear panel for dirt and tightness.

*c. Converter* (fig. 5). If the converter is accessible, make certain that electrical connectors J204 and J205 at the rear of the converter are mated with corresponding rack connectors J302 and J303 and that the conical studs on the converter are firmly held by the nut-and-link arrangements on the rack (fig. 8). Make sure that the converter is free of dust, dirt, and grease.

*d. Course Indicator* (fig. 6). Make sure that the course indicator is properly secured to the aircraft console panel. If the rear of the indicator is accessible, see that electrical connector J1601 on the course indicator is secured to the input cable. Check the course indicator glass for cracks and breaks. Operate the course selector knob to be sure that the knob is tight on its shaft and turns freely.

*e. Mounting* (fig. 7). If the mounting is accessible, check the screws that connect the mounting to the aircraft, making certain that the mounting is secured and that the grounding straps are making good contact. Check the rubber shock mounts on the mounting to make sure that they are not cracked or deteriorated.

*f. Rack* (fig. 8). If the rack is accessible, make sure that the rack snapslides are closed, securing the rack to the mounting.

Check the connections to electrical connectors J304, J305, and J306 on the top panel of the rear distribution box of the rack to make sure that they are tight and free of dirt.

*g. Power Supply* (fig. 9). If the power supply is accessible, make sure that the four snapslides are securely connected to the vhf navigation receiver.

*h. Vhf Navigation Receiver* (fig. 10). If the receiver is accessible, make certain that electrical connector J4 at the rear of the unit is mated with corresponding rack connector J301 and that the conical studs on the vhf navigation receiver are firmly held by the nut-and-link arrangements on the rack (fig. 8).

### 36. Preflight Inspections, Power On

The following procedures are to be followed while the aircraft is still on the ground. They may be performed while the aircraft is on the flight line, or, if necessary, on the apron or the taxiway.

*Note.* The following inspection procedure cannot be performed unless there is a VOR station which is in-range, but which is not associated with the airfield at which the inspection is being performed.

*a.* Energize the aircraft switch or circuit breaker applying 28-volt primary power to vhf navigation set (para 21a).

*b.* Allow approximately 3 minutes for warmup.

*c.* Adjust the aircraft panel light control. Refer to the applicable aircraft technical manual for proper procedures. The panel lamps on the vhf navigation control unit (fig. 4) should light.

*d.* Turn the VOL-OFF switch and control knob on the vhf navigation control unit (fig. 11) clockwise to energize the vhf navigation set. A hiss should be heard over the aircraft intercommunication system as the VOL-OFF switch and control knob is turned further clockwise.

*e.* Set the megacycle channel selector switch and/or the fractional megacycle channel selector switch on the vhf navigation control unit so that the MC dials indicate the frequency of the localizer station for the airfield. The OFF vertical flag on the course indicator (fig. 12) should

move out of view, the vertical pointer should center if the aircraft is on the runway centerline, and the station call sign should be heard either in code or voice signal over the aircraft intercommunication system.

*f.* Adjust the VOL-OFF switch and control knob on the vhf navigation control unit (fig. 11). Clockwise rotation of the knob should increase the amplitude of the station call sign heard on the aircraft intercommunication system; counterclockwise rotation should decrease the amplitude of the station call sign.

*g.* Set the megacycle channel selector and/or fractional megacycle channel selector switches on the vhf navigation control unit so that the MC dials indicate an unassigned or out-of-range frequency. The OFF vertical flag on the course indicator (fig. 12) should appear.

*h.* Adjust the SQUELCH control on the vhf navigation control unit (fig. 11). The level of the hissing noise heard over the aircraft intercommunication system should increase with counterclockwise rotation of the SQUELCH control and should decrease with clockwise rotation of the SQUELCH control.

*i.* Set the megacycle channel selector and/or fractional megacycle channel selector switches on the vhf navigation control unit so that the MC dials indicate the frequency of the nearest VOR station not immediately associated with the airport. Refer to the proper aeronautical chart for the frequency and location of the VOR stations. The call sign of the station should be heard on the aircraft intercommunication system, the OFF vertical flag on the course indicator (fig. 12) should move out of view, and the TO-FROM meter should indicate the direction of the VOR station with respect to the heading of the aircraft.

*Note.* It may be necessary to adjust the SQUELCH and/or VOL-OFF switch and control knobs to hear the call sign over the aircraft intercommunication system.

*j.* Note all discrepancies on DA Form 2391-2.



### 37. Flight Inspection

Perform the following checks during airborne operation to check the performance of the vhf navigation set. If the vhf navigation set should fail or operate unsatisfactorily during these checks, note the nature of the unsatisfactory operation and the conditions under which the failure occurred. This information is valuable to the repairman when he corrects the cause of trouble.

a. Apply primary power to the vhf navigation set and connect the audio output circuit of the vhf navigation set to the aircraft intercommunication system. Refer to the applicable aircraft technical manual for the proper procedures.

b. Turn the VOL-OFF switch and control knob on the vhf navigation control unit (fig. 11) clockwise to energize the vhf navigation set.

c. Set the megacycle channel selector and/or the fractional megacycle channel selector switch on the vhf navigation control unit so that the MC dials read the frequency of an in-range VOR station.

d. Listen for the station call sign. Adjust the audio level to the aircraft intercommunication system if necessary (para 21f). Note the identifying signal to be sure that the proper station is tuned in. Be sure that the OFF vertical flag (fig. 12) is out of sight on the course indicator and the TO-FROM meter is indicating either TO or FROM.

e. Adjust the course selector knob on the course indicator so that the course pointer indicates a selected reading on the course dial.

f. Fly the aircraft to center the vertical pointer on the indicator.

g. Set the megacycle channel selector switch and fractional megacycle channel selector switch on the vhf navigation control unit (fig. 11) to the nearest localizer station frequency as read on the MC dials.

h. Check the OFF vertical flag on the course indicator (fig. 12) to make certain that it is out of sight as soon as the localizer transmission can be heard on the aircraft intercommunication system.

i. Note all discrepancies on DA Form 2391-2.

# CHAPTER 3

## ORGANIZATIONAL MAINTENANCE INSTRUCTIONS

### Section I. GENERAL

#### 38. Scope of Maintenance Instructions

*Note.* The pilot will not perform preventive or corrective maintenance.

*a. General.* Organizational maintenance of the vhf navigation set, as performed by the organizational repairman or aircraft crew chief (second echelon) consists of preventive maintenance (para 39), corrective maintenance using visual inspection and the equipment performance checklist (para 40 and 41), and removal and replacement of panel lamps, knobs, and major units (para 42 through 44). Use DA Form 2391 (para 2c) to report all deficiencies, malfunctions, or abnormal conditions that cannot be remedied. For more specific details for performing preventive or corrective maintenance, refer to the technical manual covering the aircraft in which the vhf navigation set is installed.

*b. Tools, Materials, and Test Equipment Required.* The tools, materials, and test equipment required for organizational maintenance consist of the following:

- (1) Tool Equipment TE-41 or TK-115/U (tool kit).
- (2) Multimeter AN/URM-105 (multimeter).
- (3) Fine sandpaper, No. 000.
- (4) A clean dry lint-free cloth.
- (5) A soft bristle brush.
- (6) Cleaning Compound (Federal stock No. 7930-395-9542).

#### 39. Preventive Maintenance

*a. Techniques.*

- (1) Use sandpaper to remove rust and corrosion.
- (2) Use the cloth or brush for cleaning. If necessary, clean the parts, including electrical contacts, with a cloth moistened with cleaning compound; wipe the parts dry with a clean cloth.

*Caution:* Cleaning compound is flammable and its fumes are toxic. Do not use near a flame; provide adequate ventilation.

*b. Instructions.*

- (1) Check for completeness and general condition of the vhf navigation receiver, converter, vhf navigation control unit, mount, rack, course indicator, power supply, and antenna. Make sure that no knobs, screws, or lamps are missing. Replace all missing or broken knobs, all missing screws, and all missing or defective panel lamps. Check the course indicator face for cracks in the glass.
- (2) Remove dirt and moisture from the component panels, cables, and electrical connectors. Disconnect the electrical connectors, clean the contacts, and reconnect them.
- (3) Inspect all metal surfaces on the components and electrical connectors for rust and corrosion. Remove the rust and corrosion with fine sandpaper.
- (4) Inspect the cables and shock mounts for cuts, kinks, breaks, fraying, and signs of excessive strain. Check all components to assure each is properly secure and properly safety-wired.
- (5) Check all controls and accessible items (knobs, screws, nuts, etc) to make sure they are properly tightened. Tighten any loose item.
- (6) Inspect all controls for easy operation.
- (7) Check for normal operation of the vhf navigation set; be alert for any unusual operating conditions. Refer to the equipment performance checklist (para 41).

## Section II. CORRECTIVE MAINTENANCE

### 40. Visual Inspection

a. When the equipment fails to perform properly during the preflight or flight inspection procedures performed by the operator, check for the following:

- (1) Wrong setting of switches and controls on the course indicator or vhf navigation control unit.
- (2) Disconnected or poorly connected cable assemblies, cable harness, primary powerline (LV+), or aircraft intercommunication system connection line.
- (3) Cracks in the course indicator meter face.
- (4) Defective cable harness or cable assembly connector.
- (5) Sharply bent or broken course selector shaft on course indicator; shafting should rotate freely.

(6) Grounded or broken antenna coaxial cable.

b. If the above checks do not locate the trouble, proceed to the equipment performance checklist (para 41).

### 41. Equipment Performance Checklist

The equipment performance checklist is a systematic troubleshooting procedure to isolate trouble with a minimum of wasted effort. Perform the visual inspection (para 40); then, operate the equipment as directed in the equipment performance checklist and look for the normal indications listed. If an abnormal indication is observed, follow the corrective measures outlined in the final column of the checklist and follow each step in order.

	Step	Unit	Action	Normal indication	Corrective measure
P R E L I M I N	1	All.	Perform visual inspection.		
	2	Vhf navigation control unit (fig. 4).	Place SQUELCH control completely counterclockwise. Place VOL-OFF switch and control knob at OFF.		
S T A R T	3	Aircraft switch or circuit breaker for 28-volt input to vhf navigation set.	Energize. Refer to applicable aircraft technical manual for proper procedures.	Panel markings and MC dials on vhf navigation control unit glow.	Check to see if aircraft power is available at switch or circuit breaker; use multimeter. Refer to the applicable aircraft technical manual. Replace defective panel lamps (para 42).
	4	Vhf navigation control unit (fig. 4).	Turn VOL-OFF switch and control knob clockwise.	Receiver noise heard over aircraft intercommunication system.	Perform step 5; if normal indication is obtained on course indicator, check electrical connection between terminal E of connector J2 of vhf navigation control unit and aircraft intercommunication wiring. Remove primary power from vhf navigation set. Rotate VOL-OFF switch and control knob on vhf navigation control unit counterclockwise, but not OFF. Remove cable to electrical connector J2 (fig. 4) and connect multimeter between pins B and E of J2 (fig. 19). Rotate VOL-OFF switch and control knob (fig. 11) clockwise and then counterclockwise. Multimeter should indicate a steady decrease and then increase in resistance. If not, replace vhf navigation control unit (para 44c and d).

	Step	Unit	Action	Normal indication	Corrective measure
					<p>Replace power supply (para 44 <i>i</i> and <i>j</i> ).</p> <p>Replace vhf navigation receiver (para 44 <i>g</i> and <i>h</i> ).</p> <p>Replace rack (para 44 <i>m</i> and <i>n</i> ).</p>
E Q U I P M E N T  P E R F O R M A N C E	5	Vhf navigation control unit.	Set megacycle channel selector switch and/or fractional megacycle switch (fig. 11) so that MC dials indicate frequency of VOR station.	OFF vertical flag on course indicator (fig. 12) drops out of sight. TO-FROM meter indicates either TO or FROM and station call signs can be heard over aircraft intercommunication system.	<p>If normal indications are observed, remove converter from rack (para 44 <i>e</i>) and check windows on right side of vhf navigation receiver (fig. 10) to insure that frequency dials have same reading as MC dials on vhf navigation control unit (fig. 11). If readings are not the same, replace vhf navigation receiver (para 44 <i>g</i> and <i>h</i>). If trouble persists, replace vhf navigation control unit (para 44 <i>c</i> and <i>d</i> ).</p> <p>If indications on course indicator (fig. 12) are normal, but station call signs cannot be heard over aircraft intercommunication system, turn VOL-OFF switch and control knob (fig. 11) clockwise and SQUELCH control counterclockwise. If trouble persists, replace vhf navigation receiver (para 44 <i>g</i> and <i>h</i>). If trouble persists, replace rack (para 44 <i>m</i> and <i>n</i> ).</p> <p>If station call signs can be heard over aircraft intercommunication system, but indications on course indicator (fig. 12) are not normal, replace converter (para 44 <i>e</i> and <i>f</i> ). If trouble persists, replace rack (para 44 <i>m</i> and <i>n</i> ). If trouble persists, replace course indicator (para 44 <i>k</i> and <i>l</i> ).</p>
	6	Course indicator (fig. 12).	Turn course selector knob.	<p>Course pointer should move around course dial.</p> <p>Vertical pointer should center at one point of course selector knob rotation and deflect to the right and left on either side of this point.</p>	<p>Replace course indicator (para 44 <i>k</i> and <i>l</i> ).</p> <p>Replace converter (para 44 <i>e</i> and <i>f</i> ).</p> <p>Replace course indicator (para 44 <i>k</i> and <i>l</i> ).</p> <p>Replace rack (para 44 <i>m</i> and <i>n</i> ).</p>
	7	Vhf navigation control unit (fig. 11).	Set megacycle channel selector and fractional megacycle channel selector switches so that MC dials read frequency of localizer station.	OFF vertical flag on course indicator drops out of sight, and station call letters can be heard over aircraft intercommunication system.	<p>Replace converter (para 44 <i>k</i> and <i>l</i> ).</p> <p>Replace vhf navigation receiver (para 44 <i>g</i> and <i>h</i> ).</p>
	8	Vhf navigation control unit.	Place VOL-OFF switch and control knob completely counterclockwise.	OFF vertical flag on course indicator appears.	Replace course indicator (para 44 <i>k</i> and <i>l</i> ).
	9	Aircraft switch or circuit breaker for 28-volt input to vhf navigation set.	Deenergize. Refer to applicable aircraft technical manual.	Vhf navigation control unit lamps go out.	Check aircraft switch or circuit breaker.

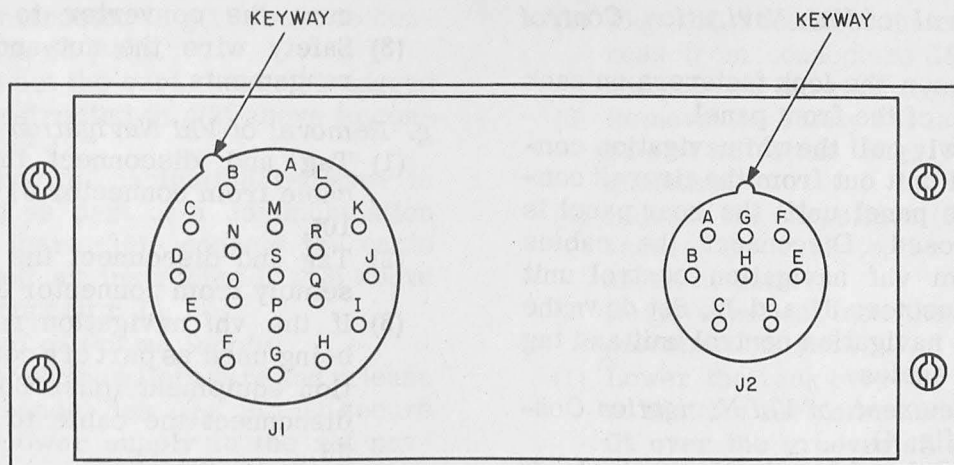

TM5826-215-12-21

Figure 19. Vhf navigation control unit connectors.

#### 42. Removal and Replacement of Vhf Navigation Control Unit Panel Lamps

a. Unscrew the lamp housing on the vhf navigation control unit (fig. 4) by grasping the lamp housing and turning counterclockwise.

b. Insert a knife blade or other sharp edge between the flange on the end of the lamp bulb and the threading on the lamp housing.

c. Pry out the lamp bulb.

d. Replace the defective lamp bulb with a new lamp bulb. Push the replacement lamp bulb into the lamp housing until the lamp bulb flange is flush with the threading on the lamp housing.

e. Press the lamp housing gently into the front panel of the vhf navigation control unit and turn clockwise to lock it in place.

#### 43. Removal and Replacement of Vhf Navigation Control Unit and Course Indicator Knobs

a. Insert an Allen wrench of appropriate size in the head of the setscrew that holds the knob to the control or switch shaft.

b. Turn the Allen wrench counterclockwise to loosen the setscrew.

c. Slide the knob off the shaft.

d. Slide the replacement knob on the shaft.

e. Tighten the replacement knob setscrew with the Allen wrench.

#### 44. Removal and Replacement of Major Components of Vhf Navigation Set

*Note.* These are only *general* procedures for the removal and replacement of the components of the vhf navigation set. For *detailed* procedures and the location of the components in or on a particular aircraft, refer to the applicable aircraft technical manual.

##### a. Removal of Antenna (fig. 3).

(1) Remove the hardware that attaches the antenna to the skin of the aircraft.

(2) Slowly pull the antenna a short distance from the aircraft.

(3) Disconnect the coaxial connector (or connectors if the glide-slope antenna is being used) from the antenna base.

##### b. Replacement of Antenna (fig. 3).

(1) Hold the antenna a short distance from the skin of the aircraft and connect the coaxial cable from the vhf navigation receiver to the VOR and localizer UG-291/U connector. If a glide-slope receiver is used in the aircraft, connect the coaxial cable from the glide-slope receiver to the glide-slope UG-291/U connector.

(2) Secure the antenna to the aircraft with the appropriate hardware.

*c. Removal of Vhf Navigation Control Unit (fig. 4).*

- (1) Loosen the lock fasteners on each side of the front panel.
- (2) Slowly pull the vhf navigation control unit out from the aircraft console panel until the rear panel is exposed. Disconnect the cables from vhf navigation control unit connectors J1 and J2. Set down the vhf navigation control unit and tag the cables.

*d. Replacement of Vhf Navigation Control Unit (fig. 4).*

- (1) Hold the vhf navigation control unit a short distance from the aircraft console panel and connect the cables tagged in c(3) above to connectors J1 and J2.
- (2) Slide the vhf control unit into the aircraft console panel and secure with the lock fasteners.

*e. Removal of Converter.*

- (1) Remove the safety wire between the nut-and-link arrangements on the converter compartment side of the rack (fig. 8).
- (2) Unscrew the knurled nuts on the nut-and-link arrangements which secure the converter to the rack. Remove the links of the nut-and-link arrangements from the conical studs on the converter (fig. 5).
- (3) Slide the converter forward from back of the rack to disconnect connectors J204 and J205 on the converter from connectors J302 and J303 on the rack.
- (4) Remove the converter from the rack.

*f. Replacement of Converter.*

- (1) Place the converter in the converter compartment of the rack (fig. 8). Slide the converter towards the back of the rack to engage connectors J204 and J205 on the converter with connectors J302 and J303 on the rack.
- (2) Place the links of the rack nut-and-link arrangements (fig. 8) over the conical studs on the converter (fig. 5). Tighten the knurled nuts of the nut-and-link arrangements to se-

cure the converter to the rack.

- (3) Safety wire the nut-and-link arrangements.

*g. Removal of Vhf Navigation Receiver.*

- (1) Tag and disconnect the coaxial cable from connector J1 ANT (fig. 10).
- (2) Tag and disconnect the cable assembly from connector J2.
- (3) If the vhf navigation receiver is being used as part of a communication equipment (para 30), tag and disconnect the cable to connector J3.
- (4) Remove the safety wire between the nut-and-link arrangements on the vhf navigation receiver compartment of the rack (fig. 8).
- (5) Unscrew the knurled nuts of the nut-and-link arrangements that secure the vhf navigation receiver to the rack. Remove the links of the nut-and-link arrangements from the conical studs on the vhf navigation receiver.
- (6) Slide the vhf navigation receiver forward away from the back of the rack to disengage connector J4 on the vhf navigation receiver from J301 on the rack.
- (7) Remove the vhf navigation receiver from the rack.

*h. Replacement of Vhf Navigation Receiver.*

- (1) Place the vhf navigation receiver in the vhf navigation receiver compartment of the rack (fig. 8). Slide the vhf navigation receiver towards the back of the rack to engage connector J4 of the vhf navigation receiver with connector J301 of the rack.
- (2) Place the links of the rack nut-and-link arrangements over the conical studs (fig. 10) of the receiver. Tighten the knurled nuts of the nut-and-link arrangements to secure the vhf navigation receiver to the rack.
- (3) Safety-wire the nut-and-link arrangements.
- (4) Connect the coaxial cable tagged

as instructed in *g*(1) above to connector J1 ANT.

- (5) Connect the cable assembly tagged as instructed in *g*(2) above to connector J2.
- (6) If the vhf navigation receiver is used as part of a communication set (para 30), connect the cable tagged as instructed in *g*(3) above to connector J3.

*i. Removal of Power Supply.*

- (1) Remove the safety wire and release the snapslides (fig. 9) that secure the power supply to the vhf navigation receiver (fig. 1).
- (2) Lift the power supply up and away from the vhf navigation receiver.

*j. Replacement of Power Supply.*

- (1) Lower the power supply onto the rear top of the vhf navigation receiver (fig. 1). Push the power supply down until connector J101 on the power supply (fig. 9) mates with the power supply connector on the vhf navigation receiver.
- (2) Secure and safety-wire the snapslides on the power supply.

*k. Removal of Course Indicator.*

- (1) Remove the three machine screws and locknuts that hold the course indicator to the shock-absorbing panel of the aircraft.
- (2) Slowly slide the course indicator out of the aircraft panel.
- (3) Tag and disconnect the indicator plug from the indicator.

*l. Replacement of Course Indicator.*

- (1) Connect the indicator plug tagged as instructed in *k*(3) above to the rear of the course indicator.
- (2) Slide the course indicator into the cutout in the aircraft shock-absorbing panel.
- (3) Secure the indicator to the aircraft panel; use the three machine screws and locknuts.

*m. Removal of Rack.*

- (1) Remove the converter (*e* above) and the vhf navigation receiver (*g* above) from the rack.

- (2) Tag and disconnect the cable harness from connectors J304, J305, and J306 on the rack (fig. 8).

- (3) Remove the safety wires from the grooved studs (fig. 7) on the mounting.

- (4) Release the snapslides (fig. 8) that secure the rack to the mounting shock mounts.

- (5) Remove the rack from the mounting.

*n. Replacement of Rack.*

- (1) Lower the rack over the mounting so that the rack snapslides (fig. 8) fit over the grooved studs (fig. 7) on the mounting shock mounts.

**Warning: Make certain that the grounding straps on the mounting are making contact with the rack at the point of contact of the mounting shock mount and rack snapslide.**

- (2) Secure the rack snapslides (fig. 8).

- (3) Safety-wire the grooved studs on the mounting shock mounts.

- (4) Connect the cable harness tagged as instructed in *m*(2) above to connectors J304, J305, and J306 on the rack.

- (5) Replace the converter (*f* above) and vhf navigation receiver (*h* above) on the rack.

*o. Removal of Mounting.*

- (1) Remove the rack from the mounting (*m* above).

- (2) Remove the hardware that secures the mounting to the surface of the aircraft.

- (3) Remove the mounting.

*p. Replacement of Mounting.*

- (1) Clean the surface around the holes that have been drilled for installation of the mounting. Use emery cloth or fine sandpaper, to insure a bare metal connection for the mounting so that proper grounding can be accomplished.

- (2) Secure the mounting to the aircraft mounting surface with the appropriate hardware.

- (3) Replace the rack on the mounting (*n* above).

## CHAPTER 4

# DEMOLITION OF MATERIEL TO PREVENT ENEMY USE

---

### 45. Authority for Demolition

The demolition procedures in paragraph 46 will be used to prevent the enemy from using or salvaging any parts of the vhf navigation set. Demolition of the vhf navigation set will be accomplished only upon the order of the commander.

### 46. Methods of Destruction

Any or all of the methods of destruction below may be used. The time available will determine the destruction methods. Also, the tactical situation will determine how the destruction order will be carried out. In most cases, it is preferable to demolish completely some portions of the vhf navigation set rather than partially destroy all the components.

*a. Smash.* Smash the vhf navigation set components; use sledges, axes, hammers, crowbars, and any other heavy tools available.

*b. Cut.* Cut the cable harness, cables, and coaxial cables; use axes, handaxes, machetes, and similar tools.

*c. Burn.* Burn as much of the equipment as is flammable; use gasoline, oil, flamethrowers, and similar tools. Burn the instruction literature first. Pour gasoline on the cut cables and internal wiring and ignite it. Use a flamethrower to burn spare parts or pour gasoline on the spares and ignite them. Use incendiary grenades to complete the destruction of the vhf navigation set components.

**Warning:** Be extremely careful with explosives and incendiary devices. Use these items only when the need is urgent.

*d. Explode.* Use explosives to complete demolition or to cause maximum damage, before burning, when time does not permit complete demolition by other means. Powder charges, fragmentation grenades, or incendiary grenades may be used. Incendiary grenades usually are most effective.

*e. Dispose.* Bury or scatter destroyed parts or throw them into nearby waterways. This is particularly important if a number of parts have not been completely destroyed.



# APPENDIX I

## REFERENCES

Following is an applicable reference available to the operator of the vhf navigation set:

TM 11-6625-203-12

Operation and Organizational Maintenance, Multimeter AN/URM-105, including Multimeter ME-77/U

# APPENDIX II

## MAINTENANCE ALLOCATION

### Section I. INTRODUCTION

#### 1. General

a. This appendix assigns maintenance functions and repair operations to be performed by the lowest appropriate maintenance echelon.

b. Columns are as follows:

- (1) *Part or component*. This column shows only the nomenclature or standard item name. Additional descriptive data are included only where clarification is necessary to identify the part. Components and parts comprising a major end item are listed alphabetically. Assemblies and subassemblies are in alphabetical sequence with their components listed alphabetically immediately below the assembly listing.
- (2) *Maintenance function*. This column indicates the various maintenance functions allocated the echelon capable of performing the operations.
  - (a) *Service*. To clean, to preserve, and to replenish fuel and lubricants.
  - (b) *Adjust*. To regulate periodically to prevent malfunction.
  - (c) *Inspect*. To verify serviceability and to detect incipient electrical or mechanical failure by scrutiny.
  - (d) *Test*. To verify serviceability and to detect incipient electrical or mechanical failure by use of special equipment such as gages, meters, etc.
  - (e) *Replace*. To substitute serviceable assemblies, subassemblies, and parts for unserviceable components.
  - (f) *Repair*. To restore an item to serviceable condition through correction of a specific failure

or unserviceable condition. This function includes, but is not limited to, inspecting, cleaning, preserving, adjusting, replacing, welding, riveting, and straightening.

- (g) *Align*. To adjust two or more components of an electrical system so that their functions are properly synchronized.
  - (h) *Rebuild*. To restore an item to a standard as near as possible to original or new condition in appearance, performance, and life expectancy. This is accomplished through the maintenance technique of complete disassembly of the item, inspection of all parts or components, repair or replacement of worn or unserviceable elements using original manufacturing tolerances and/or specifications and subsequent reassembly of the item.
  - (i) *Overhaul*. To restore an item to completely serviceable condition as prescribed by serviceability standards developed and published by heads of technical services. This is accomplished through employment of the technique of "Inspect and Repair Only as Necessary" (IROAN). Maximum utilization of diagnostic and test equipment is combined with minimum disassembly of the item during the overhaul process.
- (3) *1st, 2d, 3d, 4th, 5th echelon*. The symbol X indicates the echelon responsible for performing that particular maintenance operation, but does not necessarily indicate that repair parts will be stocked at that level. Echelons higher than the

echelon marked by X are authorized to perform the indicated operation.

(4) *Tools required.* This column indicates codes assigned to each individual tool equipment, test equipment, and maintenance equipment referenced. The grouping of codes in this column of the maintenance allocation chart indicates the tool, test, and maintenance equipment required to perform the maintenance function.

(5) *Remarks.* Entries in this column will be utilized when necessary to clarify any of the data cited in the preceding columns.

c. Columns in the allocation of tools for maintenance functions are as follows:

(1) *Tools required for maintenance functions.* This column lists tools, test, and maintenance equipment

required to perform the maintenance functions.

(2) *1st, 2d, 3d, 4th, 5th echelon.* The dagger (†) indicates the echelons allocated the facility.

(3) *Tool code.* This column lists the tool code assigned.

## **2. Maintenance by Using Organizations**

When this equipment is used by signal service organizations organic to the theater headquarters or communication zones to provide theater communications, those maintenance functions allocated up to and including fourth echelon are authorized to the organization operating this equipment.

## **3. Mounting Hardware**

The basic entries of the maintenance allocation chart do not include mounting hardware such as screws, nuts, bolts, washers, brackets, and clamps.

## Section II. MAINTENANCE ALLOCATION CHART

42

(1) PART OR COMPONENT	(2) MAINTENANCE FUNCTION	(3) 1ST ECH.	(4) 2ND ECH.	(5) 3RD ECH.	(6) 4TH ECH.	(7) 5TH ECH.	(8) TOOLS REQUIRED	(9) REMARKS
RECEIVING SET RADIO AN/ARN-30D	service		X				27, 28	External
	adjust			X			7, 8, 27, 28	
	inspect		X					External
	test			X			27, 28	
	test		X				14, 29	
	test			X			2, 4, 7, 8, 9, 10, 11, 15, 16, 18, 19, 21, 24, 25, 26, 30	
	test				X		1, 2, 5, 6, 7, 8, 9, 10, 11, 15, 16, 18, 22, 24, 25, 26, 30	
	test						1 thru 13 15 thru 18 20, 22, 23, 25, 26, 30, 31	
	repair			X			27, 28	
	algin			X			27, 28	
ANTENNA AS-580A/ARN-30	service		X					External
	inspect		X					External
	test		X	X			27, 28	
	replace		X				14	
	repair			X			29	
rebuild				X		27, 28		

(1)	(2)	(3)	(4)	(5)	(6)	(7)	(8)	(9)
PART OR COMPONENT	MAINTENANCE FUNCTION	1ST ECH.	2ND ECH.	3RD ECH.	4TH ECH.	5TH ECH.	TOOLS REQUIRED	REMARKS
AN/ARN-30D (continued)								
CONTROL RADIO SET C-3436/ARN-30D	service		X					External
	inspect		X	X				Lubricate External
	test		X	X				Operational
	test			X			11,16,25	At 5th echelon add code 3
	replace		X				29	
	repair rebuild			X	X		27,28 27,28	
CONVERTER, SIGNAL DATA CV-265A/ARN-30A	service		X					External
	adjust			X			27,28	
	inspect		X	X			7,8,27,28	Relay adjustment External
	test		X	X			27,28	Operational
	test			X			11,15,16,24,25	At 5th echelon delete code 25 Add code 23 and code 3
	replace		X				29	
	repair			X			27,28	
	align rebuild			X			11,15,16,25,30 27,28	
INDICATOR ID-453/ARN-30	service		X					External
	inspect		X					External
	test			X			11,25	
	test			X			11,25	
	test					X	3,12,13,17,20, 30,31	
	replace		X				29	
repair rebuild			X	X		27,28 27,28		
MOUNTING MT-1174/ARN-30A	service		X					
	inspect		X					
	replace		X				29	
	repair			X			27,28	
	rebuild					X	27,28	

(1) PART OR COMPONENT	(2) MAINTENANCE FUNCTION	(3) 1ST ECH.	(4) 2ND ECH.	(5) 3RD ECH.	(6) 4TH ECH.	(7) 5TH ECH.	(8) TOOLS REQUIRED	(9) REMARKS
AN/ARN-30D (continued)								
MOUNTING MT-1175/ARN-30A	service		X					External
	adjust			X			7, 8, 27, 28	Relay adjustment
	inspect		X					External
	test			X			11, 16, 25	
	replace		X				29	
	repair				X		27, 28	
POWER SUPPLY PP-2792/ARN-30D	service		X				27, 28	External
	inspect		X	X			27, 28	External
	test			X			11, 16, 26	
	test				X		11, 16, 17, 26	
	replace		X				29	
	repair			X			27, 28	
PRINTED CIRCUIT, AF	replace			X			27, 28	
	repair				X		27, 28	
PRINTED CIRCUIT, IF	replace			X			27, 28	
	repair				X		27, 28	

(1)	(2)	(3)	(4)	(5)	(6)	(7)	(8)	(9)
PART OR COMPONENT	MAINTENANCE FUNCTION	1ST ECH.	2ND ECH.	3RD ECH.	4TH ECH.	5TH ECH.	TOOLS REQUIRED	REMARKS
AN/ARN-30D (continued)								
RECEIVER RADIO R-1021/ARN-30D	service		X				27, 28	External
	inspect		X	X			27, 28	External
	test			X			2, 4, 9, 10, 11, 15, 16, 18, 19, 21, 24, 25, 30	
	test				X		1, 2, 5, 6, 9, 10, 11, 15, 16, 18, 24, 25, 30	
	test					X	1, 2, 3, 5, 6, 9, 10, 11, 12, 15, 16, 18, 23, 25, 30	
	replace		X				29	
	repair			X			27, 28	
	align			X			4, 9, 10, 11, 18, 19, 21, 25, 30	
					X		5, 6, 9, 10, 11, 15, 16, 18, 25, 30	
	rebuild					X	27, 28	

### Section III. ALLOCATION OF TOOLS FOR MAINTENANCE FUNCTIONS

46

(1) TOOLS REQUIRED FOR MAINTENANCE FUNCTIONS	(2)	(3)	(4)	(5)	(6)	(7)	(8) REMARKS
	1ST ECH.	2ND ECH.	3RD ECH.	4TH ECH.	5TH ECH.	TOOL CODE	
AN/ARN-30D (continued)							
ANALYZER, SPECTRUM TS-723/U ✓				+	+	1	
AUDIO OSCILLATOR TS-382/U ✓			+	+	+	2	
COURSE CHECKER (A.R.C. type R-16, or equal)					+	3	
FREQUENCY METER AN/URM-32			+			4	
FREQUENCY METER AN/URM-79 ✓				+	+	5	
FREQUENCY METER AN/URM-81 ✓				+	+	6	
GAGE TL-558/U ✓			+	+	+	7	
GAGE TL-559/U ✓			+	+	+	8	
GENERATOR SIGNAL AN/USM-44 ✓			+	+	+	9	
HEADSET HS-33 (or equiv) ✓			+	+	+	10	
MAINTENANCE KIT ELECTRONIC EQUIPMENT MK-252/ARN ✓			+	+	+	11	Plus adapter kit ARC No. 27452
METER TEST SET TS-682( )/GSM-1					+	12	
MODULATOR MD-83/ARN					+	13	
MULTIMETER AN/URM-105		+				14	
MULTIMETER ME-26/U ✓			+	+	+	15	
MULTIMETER TS-352/U ✓			+	+	+	16	
OHMMETER ZM-21/U ✓				+	+	17	
POWER SUPPLY PP-1104/B ✓				+	+	18	
POWER SUPPLY PP-1243/U			+			19	
RESISTANCE BRIDGE ZM-4/U					+	20	
SIGNAL GENERATOR SG-13/ARN			+			21	
TEST SET I-199 ✓				+	+	22	
TEST SET ELECTRON TUBE TV-2/U					+	23	
TEST SET ELECTRON TUBE TV-7/U ✓			+	+		24	
TEST SET RADIO AN/ARN-5 ✓			+	+	+	25	
TEST SET TRANSISTOR ✓			+	+	+	26	In development
TOOL KIT TK-87/U ✓			+	+	+	27	Use TE-114 until available
TOOL KIT TK-88( )/U ✓			+	+	+	28	Use TE-114 until available
TOOL KIT TK-115/U ✓		+				29	Use TE-41 until available
VOLTMETER METER ME-30/U ✓			+	+	+	30	
FREQUENCY METER AN/USM-26					+	31	



# APPENDIX III

## BASIC ISSUE ITEMS LIST

---

### Section I. INTRODUCTION

#### 1. General

This appendix lists items supplied for initial operation. The list includes tools, parts, and material issued as *part of* the major end item. The list includes all items authorized for basic operator maintenance of the equipment. End items of equipment are issued on the basis of allowances prescribed in equipment authorization tables and other documents that are a basis for requisitioning.

#### 2. Columns

*a. Source, Maintenance, and Recoverability Code.*

*b. Federal Stock Number.* This column lists the 11-digit Federal stock number.

*c. Designation by Model.* Not used.

*d. Description.* Nomenclature or the standard item name and brief identifying data for each item are listed in this column. When requisitioning, enter the nomenclature and description.

*e. Unit of Issue.* The unit of issue is the supply term by which the individual item is counted for procurement, storage, requisitioning, allowances, and issue purposes.

*f. Expendability.* Expendable items are indicated by the letter X; nonexpendable items are indicated by NX.

*g. Quantity Authorized.* Under "Items Comprising an Operable Equipment," the column lists the quantity of items supplied for the initial operation of the equipment.

*h. Illustrations.* The "Item No." column lists the reference designation used for identification of the items in the illustration or text of the manual.



(1) SOURCE MAINTENANCE AND RECOVERABILITY CODE	(2) FEDERAL STOCK NUMBER	(3) DESIGNATION BY MODEL	(4) DESCRIPTION	(5) UNIT OF ISSUE	(6) EXPENDABILITY	(7) QUANTITY AUTHORIZED	(8) ILLUSTRATIONS		(9)
							FIGURE NO.	ITEM NO.	
			AN/ARN-30D (continued)						
	6625-091-0494		MOUNTING MT-1174/ARN-30A: aluminum; ARC type M-10	ea	NX	1			
	5826-611-0865		MOUNTING MT-1175/ARN-30A: aluminum; ARC type E-14	ea	NX	1			
	6145-542-6092		RADIO FREQUENCY CABLE RG-58C/U: (NOTE: Authorized quantity will be a minimum or a multiple of 20 ft)	ft	X	20			W301
	5826-752-5730		RECEIVER RADIO R-1021/ARN-30D: 1 band, 108-126.90 mc, 190 channels; ARC type R-34A (28v)	ea	NX	1			
	5826-752-2508		POWER SUPPLY PP-2792/ARN-30D: crystal rectifier; full wave; ARC type DV-10A		X	1			
			RUNNING SPARES AND ACCESSORY ITEMS						
			RECEIVING SET, RADIO AN/ARN-30D						
			NO PARTS AUTHORIZED FOR STOCKAGE AT FIRST ECHELON						

## GLOSSARY

---

*Back course approach.*— A runway localizer approach in which the centering of the vertical pointer of the indicator is accomplished by flying the aircraft in the direction opposite to the direction of deflection of the vertical pointer. Thus, if the vertical pointer deflects to the left, the aircraft is flown to the right, to center the vertical pointer. Normally, a back course approach involves touching down at that runway end at which the localizer transmitter is located.

*Dipole.*— A special antenna with two poles, each approximately one-fourth the length of the radio waves antenna is to receive.

*Duct effect.*— The trapping of vhf radio waves in atmospheric ducts so that the normal range of those radio waves is greatly extended.

*Front course approach.*— A runway localizer approach in which the aircraft is flown in the same direction as the direction of deflection of the indicator vertical pointer to center the pointer.

Normally, the front course approach involves touching down at the runway end which is across the field from the localizer transmitter.

*Glide-slope.*— A portion of an instrument landing system (ILS) that provides navigational information about the aircraft's angle of glidepath to the runway let-down point.

*Localizer.*— A vhf radio system for guiding aircraft along an approach path to an airport runway.

*Omni.*— A term used for VOR operation.

*Shadow effect.*— The disappearance or reduction of amplitude of a vhf radio wave caused by the presence of large obstacles in the path of the radio beam.

*Squelch.*— To quiet a receiver automatically by reducing the receiver gain when the amplitude of receiver inputs drops below a selected level.

*VOR.*— A vhf radio system that provides navigational data in the form of bearings with respect to the radio transmitter.

By Order of Secretary of the Army:

G. H. DECKER,  
General, United States Army,  
Chief of Staff.

Official:

R. V. LEE,  
Major General, United States Army,  
The Adjutant General.

Distribution:

*Active Army:*

DASA (6)	AFIP (1)
USASA (2)	WRAMC (1)
CNGB (1)	AFSSC (1)
Tech Stf, DA (1) except	USAEPG (2)
CSigO (15)	EMC (1)
Tech Stf Bd (1)	USACA (2)
USCONARC (4)	USASEA (1)
USAARTYBD (1)	USA Caribbean Sig Agcy (1)
USAARMBD (2)	USA Sig Msl Spt Agcy (12)
USAIB (1)	USASSA (20)
USARADBD (2)	USASSAMRO (1)
USAABELCTBD (1)	Army Pictorial Cen (2)
USAAVNBD (1)	USAOMC (3)
USAATBD (1)	USA Trans Tml Comd (1)
ARADCOM (2)	Army Tml (1)
ARADCOM Rgn (2)	POE (1)
OS Maj Comd (2)	OSA (1)
OS Base Comd (2)	AMS (1)
LOGCOMD (2)	Sig Fld Maint Shops (2)
MDW (1)	JBUSMC (2)
Armies (2)	Yuma Test Sta (2)
Corps (5)	Units org under fol TOE:
USATC AD (2)	(2 copies each UNOINDC)
USATC Armor (2)	5-500 (AA-AD)
USATC Engr (2)	11-7
USATC FA (2)	11-16
USATC Inf (2)	11-57
Svc Colleges (2)	11-98
Br Svc Sch (2)	11-117
GENDEP (2) except	11-155
Atlanta GENDEP (None)	11-500 (AA-AE) (4)
Sig Sec, GENDEP (5)	11-557
Sig Dep (12)	11-587
Ft Monmouth (63)	11-592
USASATSA (5)	11-597

NG: State AG (3); Units—Same as Active Army except allowance is one copy for each unit.

USAR: None.

For explanation of abbreviations used, see AR 320-50.



CHANGE

No. 6

HEADQUARTERS,  
DEPARTMENT OF THE ARMY  
WASHINGTON, D.C., 31 July 1973

**Organizational Maintenance Manual**  
**Including Repair Parts and Special Tool Lists**  
**RECEIVING SET, RADIO AN/ARN-30D AND AN/ARN-30E**

TM 11-5826-215-12, 21 August 1961, is changed as follows:

Page 5, paragraph 1.1. Delete paragraph 1.1 and substitute:

**1.1. Indexes of Publications**

a. *DA Pam 310-4.* Refer to the latest issue of DA Pam 310-4 to determine whether there are new editions, changes, or additional publications pertaining to the equipment.

b. *DA Pam 310-7.* Refer to DA Pam 310-7 to determine whether there are modification work orders (MWO's) pertaining to the equipment.

Paragraph 2. Delete paragraph 2 and substitute:

**2. Forms and Records**

a. *Reports of Maintenance and Unsatisfactory Equipment.* Maintenance forms records, and reports which are to be used by maintenance personnel at all maintenance levels are listed in and prescribed by TM 38-750.

b. *Report of Packaging and Handling Deficiencies.* Fill out and forward DD Form

6 (Report of Packaging and Handling Deficiencies) as prescribed in AR 700-58 (Army)/NAVSUP PUB 378 (Navy)/AFR 71-4 (Air Force)/and MCO P4030.29 (Marine Corps).

c. *Discrepancy in Shipment Report (DISREP) (SF 361).* Fill out and forward Discrepancy in Shipment Report (DISREP) (SF 361) as prescribed in AR 55-38 (Army)/NAVSUP PUB 459 (Navy)/AFM 75-34 (Air Force)/and MCO P4610.19 (Marine Corps).

**2.1. Reporting of Equipment Publication Improvements**

The reporting of errors, omissions, and recommendations for improving this publication by the individual user is encouraged. Reports should be submitted on DA Form 2028 (Recommended Changes to Publications) and forwarded direct to Commander, US Army Electronics Command, ATTN: AMSEL-MA-AN, Fort Monmouth, N.J., 07703.

PROPERTY OF TECHNICAL LIBRARY  
FOR REFERENCE

Not To Be Taken From This Room

copy 1/6

5. Items Comprising Operable Receiving Sets, Radio AN/ARN-30D and AN/ARN-30E

FSN	Qty	Nomenclature, Part No., and mfr code	Usable on code
5826-752-5814		Receiving Set, Radio AN/ARN-30D	
5826-892-1056		Receiving Set, Radio AN/ARN-30E	
		consisting of:	
		NOTE	
		In the usable on code column, number 1 refers to Receiving Set, Radio AN/ARN-30D; number 2 refers to Receiving Set, Radio AN/ARN-30E.	
5985-270-8399	1	Antenna AS-580A/ARN-30; ramshorn type; for receiving VHF; ARC type A-13B	1,2
5826-752-5735	1	Control, Radio Set C-3436/ARN-30D; 28vdc; 126.90 MHz max range; ARC type C-81A	1
5826-892-1061	1	Control, Radio Set C-3436A ARN-30D; 28vdc, 108 to 126.90 MHz max range; ARC type C-88A	2
5826-505-0645	1	Converter, Signal Data CV-265A/ARN-30A; converter output indicated on external meters; ARC type B-13A-1	1,2
5826-697-9880	1	Indicator, Course ID-453/ARN-30: combined cross-pointer meter To-From meter and course selector ARC type IN-10	1,2
6625-091-0494	1	Mounting MT-1174/ARN-30A; aluminum; ARC type M-10	1,2
5826-611-0865	1	Mounting MT-1175/ARN-30A; aluminum; ARC type E-14	1,2
5826-752-2508	1	Power Supply PP-2792/ARN-30D; crystal rectifier; full wave; ARC type DV-10A	1,2
		OR	
5821-542-7937	1	Power Supply; ARC type DV-10A: rectifier type; 26 v ac, ARC part/dwg No. 19840	1,2
5826-752-5730	1	Receiver Radio R-1021/ARN-30D; 1 band, 108-126.90 mc, 190 channels; ARC type R-34A (28v)	

Page 47. Delete appendix III in its entirety.

PROPERTY OF TECHNICAL LIBRARY  
FOR REFERENCE  
Not To Be Taken From This Room



By Order of the Secretary of the Army:

CREIGHTON W. ABRAMS  
General, United States Army,  
Chief of Staff.

Official:

VERNE L. BOWERS,  
Major General, United States Army,  
The Adjutant General.

Distribution:

To be distributed in accordance with DA Form 12-36 (qty rqr block No. 148) organizational maintenance requirements for AN/ARN-30.

CHERINGTON W. ABRAMS  
General United States Army  
Chief of Staff

The Chief of the Staff of the Army

Original  
VERNE J. HOWLES  
Major General United States Army  
The Adjutant General

No.	Description
1	To be distributed in accordance with DA Form 13-37 (10-1-58) organizational main- tenance requirements for AN/AG-20
2	
3	
4	
5	
6	
7	
8	
9	
10	
11	
12	

CHANGE

No. 5

HEADQUARTERS  
DEPARTMENT OF THE ARMY  
WASHINGTON, D.C., 10 June 1965

Organizational Maintenance Manual

RECEIVING SET, RADIO AN/ARN-30D AND AN/ARN-30E

Including Repair Parts and Special Tool Lists

(As changed by C 1, 16 Jul 62) TM 11-5826-215-12, 21 August 1961, is changed as indicated so that the manual also applies to the following equipment:

Nomenclature

Order No.

Receiving Set, Radio AN/ARN-30E----- 4294-PP-61

The title (as changed by C 1, 16 Jul 62) is changed to read as shown above.

Note. The parenthetical reference to a previous change (example: "page 5 of C 2") indicates that pertinent material was published in that change.

Page 5 (as changed by C 1, 16 Jul 62). Add the following note below the title of chapter 1:

Note. Receiving Set, Radio AN/ARN-30E is similar to Receiving Set, Radio AN/ARN-30D. Information in this manual applies to both sets unless otherwise specified.

After "Control, Radio Set C-3436/ARN-30D" add "or Control, Radio C-3436A/ARN-30E" in the following places (as added by C 1, 16 Jul 62):

Page 6, figure 2, paragraph 3d, line 9.

Page 7, paragraph 4c, title.

Page 8, paragraph 5, chart, line 2, paragraph 6, chart, line 4.

Page 4, figure 1 (as added by C 1, 16 Jul 62). Add the following note to figure 1:

NOTE:

CONTROL, RADIO SET C-3436A/ARN-30E IS SIMILAR TO CONTROL, RADIO SET C-3436/ARN-30D. THE FRONT PANEL OF THE C-3436A/ARN-30E HAS "VHF ILS" ON THE LEFT SIDE IN PLACE OF "VHF NAV."

Page 5, paragraph 2 (page 1 of C 4). Delete subparagraph c and substitute:

c. Comments on Manuals. The direct reporting by the individual user of errors, omissions,

and recommendations for improving this manual is authorized and encouraged. DA Form 2028 (Recommended Changes to DA Publications) will be used for reporting these improvements. This form will be completed using pencil, pen, or typewriter and forwarded direct to Commanding General, U.S. Army Electronics Command, ATTN: AMSEL-MR-(NMP)-MA, Fort Monmouth, N.J., 07703.

Page 6, paragraph 3d (as added by C 1, 16 Jul 62). Add the following at the end of subparagraph d: Receiver Set, Radio AN/ARN-30D is supplied with Control, Radio Set C-3436/ARN-30D. The control unit is used to tune only Receiver, Radio R-1021/ARN-30D. Receiver Set, Radio AN/ARN-30E is supplied with Control, Radio Set C-3436A/ARN-30E. This control unit in addition to controlling the R-1021/ARN-30D can be used to tune an associated glide slope receiver. It controls the frequency of both Receiver, Radio R-1021/ARN-30D and the glide slope receiver. The control unit automatically tunes the R-1021/ARN-30D and the associated glide slope receiver to associated glide slope and localizer frequencies.

Note. A specific glide slope transmitter frequency is always paired with a specific localizer frequency.

\*This change supersedes C 1, 16 July 1962; TM 11-5826-215-20P, 28 February 1962; and together with TM 11-5826-220-35P, 10 June 1965, supersedes TM 11-5826-220-35P, 21 March 1962, including C 1, 27 May 1964.

Figure 2 (as added by C 1, 16 Jul 62). Add the following note to figure 2:

**NOTE:**

RECEIVING SET, RADIO AN/ARN-30E IS SUPPLIED WITH CONTROL, RADIO SET C-3436A/ARN-30E IN PLACE OF CONTROL, RADIO C-3436/ARN-30D.

Page 8, paragraph 5 (as changed by C 1, 16 Jul 62). In "Width" column, line 2, add superscript <sup>a</sup> after: 3 $\frac{3}{4}$  and add the following footnote:

Page 9, paragraph 8 (as added by C 1, 16 Jul 62). Add subparagraph *d*.

*d*. Control, Radio Set C-3436/ARN-30D has two electrical connectors mounted on the rear panel. Control, Radio Set C-3436A/ARN-30E has three electrical connectors mounted on the rear panel and has a slight increase in the physical depth of the unit.

Page 10, figure 4 (as added by C 1, 16 Jul 62). Add the following note to figure 4:

**NOTE:**

CONTROL, RADIO SET C-3436A/ARN-30E IS SIMILAR TO CONTROL, RADIO SET C-3436/ARN-30D. THE FRONT PANEL OF THE C-3436A/ARN-30E HAS "VHF ILS" ON THE LEFT SIDE IN PLACE OF "VHF NAV."

Page 14, paragraph 16 (as added by C 1, 16 Jul 62). Add paragraph *d*.

*d*. The use of Control, Radio Set C-3436A/ARN-30E with a glide slope receiver having similar frequency selection control wiring as the

<sup>a</sup>The width of the C-3436A/ARN-30E is 5 $\frac{1}{2}$  inches.

R-1021/ARN-30D permits the automatic selection of the associated glide slope frequency with the selected localizer frequency.

Page 15, paragraph 17, chart (as changed by C 1, 16 Jul 62). "Control or indicator" column, line 3. Add superscript <sup>a</sup> after "switch." Line 5. Add superscript <sup>a</sup> after "switch."

Add the following footnote:

Page 16, paragraph 19*a*, line 16 (as added by C 1, 16 Jul 62). Add the following after "111.9 mc.": When the Control, Radio Set C-3436A/ARN-30E is used and an associated glide slope receiver is connected into the system, the associated glide slope receiver frequency will be selected automatically with the selection of the localizer frequency.

Page 29, paragraph 35*b*, line 10 (as added by C 1, 16 Jul 62). Add the following sentence at end of subparagraph *b*: If Control, Radio Set C-3436A/ARN-30E is used, also check electrical connector J3.

Page 32, paragraph 39.4*e*, last line (page 3 of C 4). Delete "TM 9-213" and substitute: TB SIG 364.

Page 33, paragraph 41, chart. In item 4 "Corrective measures" column, line 14 (as changed by C 1, 16 Jul 62). Change "(fig. 19)" to: (fig. 19 and 19.1).

Page 35, figure 19, caption (as changed by C 1, 16 Jul 62). Delete the figure caption and substitute: Control, Radio Set C-3436/ARN-30D, electrical connectors.

Add figure 19.1 (as added by C 1, 16 Jul 62) after figure 19:

<sup>a</sup>For Control, Radio Set C-3436A/ARN-30E, this control, in addition to selecting the VHF navigation receiver frequency, also selects the frequency to which an associated glide slope receiver is tuned.

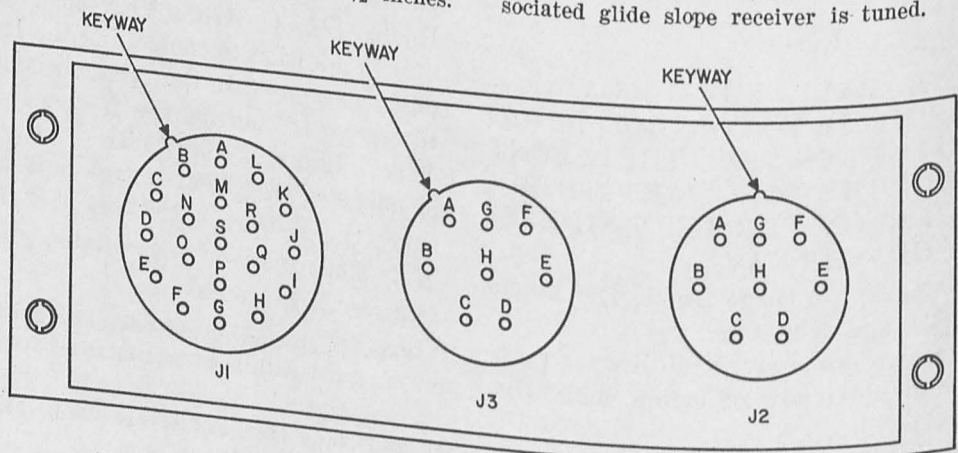

Figure 19.1. Control, Radio Set C-3436A/ARN-30E, electrical connectors.

TM5826-215-12-C1-1

Page 36, paragraph 44 (as changed by C 1, 16 Jul 62), subparagraph c(2). Delete the second sentence and substitute: Disconnect the cables from the VHF navigational control unit (fig. 19 and 19.1).

Subparagraph d(1). Delete the last two lines and substitute: cables tagged in c(2) above.

Page 39 (page 6 of C 4). Delete appendix I and substitute:

## APPENDIX I

### REFERENCES

Following is a list of references available to the operator and organizational repairman of VHF navigation set.

DA Pam 310-4	Index of Technical Manuals, Technical Bulletins, Supply Manuals (Types 7, 8, and 9), Supply Bulletins, Lubrication Orders, and Modification Work Orders.
TB SIG 364	Field Instructions for Painting and Preserving Electronics Command Equipment.
TM 11-530	Installation Practices for Aircraft Electric and Electronic Wiring.
TM 11-6625-203-12	Operator and Organizational Maintenance, Multimeter AN/URM-105, Including Multimeter ME-77/U.
TM 11-6625-366-20P	Organizational Maintenance Repair Parts and Special Tool Lists: Multimeter TS-352/U, TS-352A/U, and TS-352B/U.
TM 38-750	Army Equipment Record Procedures.

Page 44, appendix II, section II (page v of C 2). Delete the item after "Mounting MT-1175/ARN-30A" and substitute:

Part or component	Maintenance function	1st echelon	2d echelon	3d echelon	4th echelon	5th echelon	Tools required	Remarks
Power Supply PP-2792/ARN-30D and Power Supply ARC Type DV-10A (P/DWG 19840).	Service-----		X				5, 6	External.
	Inspect-----		X				5, 6	External.
	Test-----			X			1, 2, 4	
	Replace-----		X		X		1, 2, 3, 4	
	Repair-----			X			5, 6	
	Rebuild-----					X	5, 6	

Page 49. Add appendix IV after appendix III:

## APPENDIX IV

### ORGANIZATIONAL REPAIR PARTS LIST

#### Section I. INTRODUCTION

##### 1. General

a. This manual lists the repair parts authorized for organizational maintenance and constitutes a basis of requisitioning when the major item of

equipment is authorized to the organization. These equipments are issued on the basis of allowances prescribed in equipment authorization tables and other documents which are a basis of requisitioning. This equipment is combat essential.

b. Columns are as follows:

- (1) *Federal stock number.* This column lists the 11-digit Federal stock number.
- (2) *Designation by model.* The dagger (†) indicates model in which the part is used.
- (3) *Description.* Nomenclature or the standard item name and brief identifying data for each item are listed in this column. When requisitioning, enter the nomenclature and description.
- (4) *Unit of issue.* The unit of issue is each unless otherwise indicated and is the supply term by which the individual item is counted for procurement, storage, requisitioning, allowances, and issue purposes.
- (5) *Expendability.* Nonexpendable items are indicated by NX. Expendable items are not annotated.
- (6) *Quantity incorporated in unit.* This column lists the quantity of each part found

in a given assembly, component, or equipment.

- (7) *Organizational.* An asterisk indicates that an item is not authorized for stockage but if required, may be requisitioned for immediate use only.
- (8) *Illustration.* The "Figure No." column lists the figure and reference numbers used for identification of the items in the illustration.

## 2. Parts for Maintenance

When this equipment is used by signal service organizations organic to theater headquarters or communication zones to provide theater communications, those repair parts authorized up to and including general support are authorized for stockage by the organization operating this equipment.

SECTION II. ORGANIZATIONAL FUNCTIONAL PARTS LIST

FEDERAL STOCK NUMBER	DESIGNATION BY MODEL	DESCRIPTION	UNIT OF ISSUE	EXP	QTY IN UNIT	MAINT ORG ALLOW.	ILLUSTRATION	
							FIGURE NO.	ITEM NO.
5826-752-5814		RECEIVING SET, RADIO AN/ARN-30D: 1 band; 108-126.90 mc freq. range; 190 channels; 28 vdc; rack mts; ARC type 15F.		NX			1	
5826-892-1056		RECEIVING SET, RADIO AN/ARN-30E: 1 band, 108-126.90 mc freq. range; 190 channels; 28 vdc; rack mts; ARC type 15F.		NX				
		CONTROL, RADIO SET C-3436/ARN-30D; CONTROL, RADIO SET C-3436A/ARN-30D						
		CONTROL, RADIO SET C-3436/ARN-30D; CONTROL, RADIO SET C-3436A/ARN-30D		NX			1	
		NOTE: Model Column 1 refers to C-3436/ARN-30D; Model Column 2 refers to C-3436A/ARN-30D						
5820-502-9376	+ +	CAP ELECTRICAL: plastic; 25/32 in lg by 47/64 in dia			2	*		
6250-542-8507	+ +	CAP, ELECTRICAL: aluminum black anodized finished; 0.741 in lg by 0.500 in dia w/bossed edge; mts by 3/8 in -24 thd, incl red filter and rubber seal.			2	*		
5355-524-0053	+ +	KNOB: setscrew type; rd shape; 0.687 in max O cl by 0.500 in thk o/a; ARC part No. 16331			2	*		
5355-863-3783	+ +	KNOB: setscrew type; bar shape; 0.750 in max dia by 1.063 in thk o/a; ARC part No. 20403			2	*		
6240-155-7836	+ +	LAMP, INCANDESCENT: 28 vdc; T-1-3/4 bulb; General Electric type No. 327			2	*		
6250-542-6103	+ +	RETAINER, INDICATOR LIGHT: 27/32 in lg by 19/32 in dia o/a spring contact terminal hex nut. Grimes part No. A-4996			2	*		
		RECEIVER, RADIO R-1021/ARN-30D						
		RECEIVER, RADIO R-1021/ARN-30D		NX			1	
5935-614-0066		COVER, ELECTRICAL CONNECTOR: ARC part No. 14588			1	*		

AN/ARN-30D & 30E 2

By Order of the Secretary of the Army:

Official:

J. C. LAMBERT,  
*Major General, United States Army,  
The Adjutant General.*

HAROLD K. JOHNSON,  
*General, United States Army,  
Chief of Staff.*

Distribution:

To be distributed in accordance with DA Form 12-36 requirements for operator and crew for CV-2B, OV-1A, OV-1B, OV-1C, RU-8D, TO-1D, U-1A, U-6A, U-8D, U-8F, CH-21C, CH-37B, CH-47A, UH-1A, UH-1B, UH-19C, CH-34A and CH-34C aircraft.





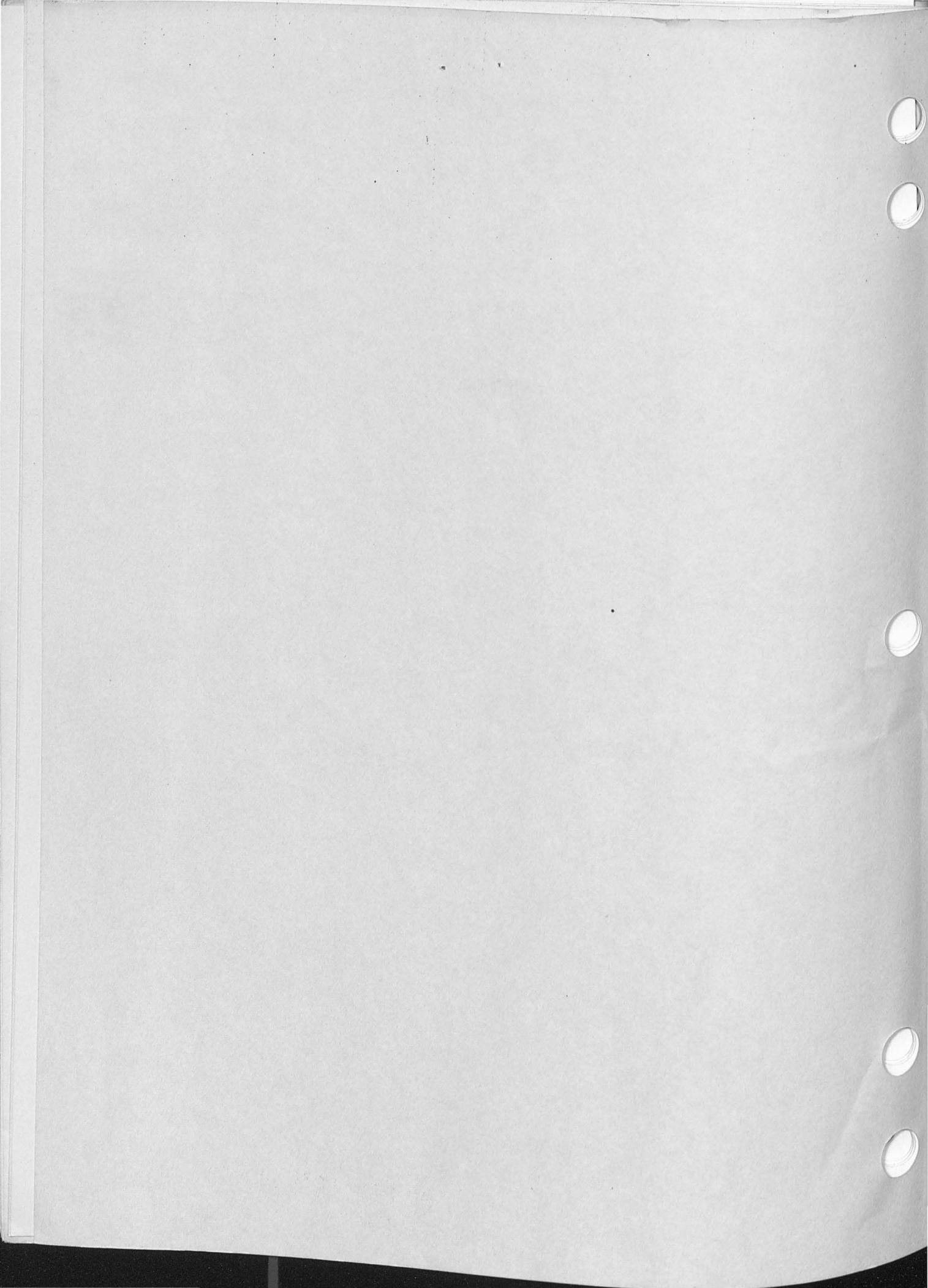

# TECHNICAL MANUAL

## Operator and Organizational Maintenance Manual

### RECEIVING SET, RADIO AN/ARN-30D AND AN/ARN-30E

TM 11-5826-215-12 }  
CHANGES No. 4 }

HEADQUARTERS,  
DEPARTMENT OF THE ARMY  
WASHINGTON 25, D.C., 19 February 1963

TM 11-5826-215-12, 21 August 1961, is changed as follows:

Change "DA Form 2391-2" to: DA Form 2408-13 in the following places:  
Page 29, paragraph 35, line 6.  
Page 30, paragraph 36j.  
Page 31, paragraph 37i.  
Page 5. Make the following changes:  
After paragraph 1, add—

#### 1.1. Index of Publications

Refer to the latest issue of DA PAM 310-4 to determine whether there are new editions, changes, or additional publications pertaining to your equipment. Department of the Army Pamphlet No. 310-4 is a current index of technical manuals, technical bulletins, supply bulletins, lubrication orders, and modification work orders that are available through publications supply channels. The index lists the individual parts (-10, -20, -35P, etc.) and the latest changes to and revisions of each equipment publication.

Delete paragraph 2 and substitute:

#### 2. Forms and Records

a. *Reports of Maintenance and Unsatisfactory Equipment.* Use equipment forms and records accordance with instructions in TM 38-750.

b. *Report of Damaged or Improper Shipment.* Fill out and forward DD Form 6 (Report of Damaged or Improper Shipment) as prescribed in AR 700-58, (Army), NAVSANDA publication 378 (Navy), and AFR 71-4 (Air Force).

c. *Comments on Manual.* Forward all comments on this publication direct to: Commanding Officer, U.S. Army Electronics Materiel Support Agency, ATTN: SELMS-MP, Fort Monmouth, N.J. (DA Form 1598 (Record of Comments on Publications), DA Form 2496 (Disposition Form), or letter may be used.)

Page 32. Delete section I and substitute:

## Section I. MAINTENANCE SERVICE AND INSPECTION

### 38. Scope of Maintenance

*Note.* The pilot will not perform preventive or corrective maintenance.

The maintenance duties assigned to the organizational maintenance repairman are listed below together with a reference to the paragraphs covering the specific maintenance function. The duties include instructions for performing preventive maintenance and corrective maintenance and do not require tools or test equipment other than those allocated at second echelon (par. 39).

a. Daily maintenance service and inspection (par. 39.2).

b. Cleaning (par. 39.4).

c. Intermediate maintenance service and inspection (par. 39.5).

d. Periodic maintenance service and inspection (par. 39.7).

e. Repairs and adjustments:

(1) Removal and replacement of vhf navigation control unit panel lamps (par. 42).

Copy 3/4

- (2) Removal and replacement of vhf navigation control unit and course indicator knobs (par. 43).
- (3) Removal and replacement of major components of vhf navigation set (par. 44).

### 39. Tools, Materials, and Test Equipment Required

The tools, materials, and test equipment required for maintenance at the organizational level are:

- a. Tool Kit, Radio Repair TK-115/G.
- b. Multimeter AN/URM-105 (multimeter).
- c. Fine sandpaper, No. 000.
- d. A clean, dry, lint-free cloth.
- e. A soft bristle brush.
- f. Cleaning Compound (Federal stock No. 7930-395-9542).

#### 39.1. Preventive Maintenance

Preventive maintenance is the systematic care, servicing, and inspection of equipment to prevent the occurrence of trouble, to reduce downtime, and to assure that the equipment is serviceable. Preventive maintenance is the responsibility of all echelons concerned with the equipment and includes the inspection, testing, and repair or replacement of components that inspection and tests indicate would probably fail before the next scheduled service period. Preventive maintenance service and inspections of Receiving Sets Radio AN/ARN-30D and AN/ARN-30E at the organizational level are made at daily, intermediate, and periodic intervals unless otherwise directed by the commanding officer. The maintenance services should be performed concurrently with the inspection schedules of the aircraft.

a. *Systematic Care.* The procedure given in paragraphs 39.2 through 39.8 cover systematic care essential to proper upkeep and operation of the equipment. The cleaning operations (par. 39.4 a through d) should be performed once a day. If the equipment is not used daily, however, the cleaning operations must be performed before operation, after any extended

shutdown, or once a week while the equipment is kept in *standby* condition. The other items must be checked before the equipment is placed in operation after shutdown, during operation, or after it is turned off, as specified in the applicable paragraph.

b. *Maintenance and Service Inspection.* The maintenance service and inspection charts (par. 39.3, 39.6, and 39.8) outline inspections to be made at specific intervals. These inspections are made to determine combat serviceability; that is, to determine that the equipment is in good general (physical) condition, in good operating condition, and likely to remain combat serviceable. To assist the organizational repairman in determining and maintaining combat serviceability, the charts indicate what to inspect, how to inspect, and what the normal conditions are; the *References* column lists the paragraph that contains additional information. If the defect cannot be remedied by the organizational maintenance repairman, higher echelon maintenance or repair is required. Records and reports of these inspections must be made in accordance with TM 38-750.

c. *Maintenance Forms and Records.* Maintenance forms and records to be used and maintained on this equipment are specified in TM 38-750. Paragraph 2 contains additional information concerning submission of specific forms.

#### 39.2. Daily Maintenance Service and Inspection

Daily maintenance service and inspections of the AN/ARN-30D and AN/ARN-30E are required in an aircraft installation. Paragraph 39.3 specifies services and inspections that must be accomplished daily and under special conditions listed below:

- a. Following the last flight of each day or preceding the next day's flight.
- b. When the equipment is replaced after removal for any reason.
- c. At least once a week if the equipment is maintained in *standby* condition.

### 39.3. Daily Maintenance Service and Inspection Chart

*Note.* The items numbers in the chart below are not consecutive; they are taken from the complete periodic maintenance service and inspection chart (par. 39.8).

Item No.	Procedure		References
	Item	Normal condition or result	
1	SET: Inspect all equipment components for completeness and general operational condition. Check for evidence of damage, security of mounting, and safety wiring.	Equipment must be complete, clean, and installed properly for operation. Equipment components must be properly secured and in good external condition.	Applicable aircraft technical manual and par. 39.4.
5	CONNECTIONS: Check external cables, connectors, and receptacles for evidence of external damage. Check antenna lead-in for evidence of damage and security of installation.	Connectors and receptacles are clean and intact. Cables are clean, secure, and in good condition.	Applicable aircraft technical manual.
6	KNOBS, DIALS, AND SWITCHES: Check for proper mechanical action by setting each control to each of its possible settings. NO CONTROL CHECK IS MADE ON THE CONVERTER, the controls are set and locked during alignment.	Action is positive and smooth. There is no evidence of binding or scraping. (Upon completion of the checks, return all controls to their <i>off</i> positions.)	Par. 35b and d.
8	OPERATIONAL CHECK: Perform a complete operational check.	Equipment operates in accordance with referenced operating instructions.	Par. 36 and 37.

### 39.4. Cleaning

*Note.* Perform the following procedures as referenced by the maintenance and service inspection charts.

Inspect all components of the vhf navigation set. The exterior surfaces should be clean, free of moisture, dirt, grease, and fungus.

a. Remove moisture and loose dirt with the clean soft cloth.

**Warning:** Cleaning compound is flammable and its fumes are toxic. Provide adequate ventilation. Do not use near a flame.

b. Remove grease, fungus, and ground-in dirt with a cloth dampened (not wet) with cleaning compound..

c. Remove dirt from the exposed connectors with a brush, and remove moisture with a dry cloth.

**Caution:** Do not press on the course indicator glass when cleaning; the glass may be damaged.

d. Clean the front panel of the vhf navigation control unit and the course indicator glass; use a soft clean cloth. If dirt is difficult to remove, dampen the cloth with water; mild soap may be used to make the cleaning more effective.

e. Remove rust and corrosion from metal surfaces by lightly sanding them with fine sandpaper. Brush two thin coats of paint on the bare metal to protect it from further corrosion. Refer to applicable cleaning and refinishing practices specified in TM 9-213.

### 39.5. Intermediate Maintenance Service and Inspection

The intermediate inspection provides verification of satisfactory operation at intervals between the daily and periodic inspections. Perform the maintenance functions indicated in the intermediate maintenance and inspection chart (par. 39.6) every 25 flying hours. The intermediate inspection should be performed concurrently with the intermediate maintenance performed on the aircraft in which the equipment is installed. Adjustments of the maintenance interval must be made to compensate for any unusual operating conditions. Equipment maintained in a standby (ready for immediate operation) condition, must have intermediate maintenance performed on it. Equipment in limited storage (requires service before operation) does not require intermediate inspection.

### 39.6. Intermediate Maintenance Service and Inspection Chart

Note. The items numbers in the chart below are not consecutive; they are taken from the complete periodic maintenance service and inspection chart (par. 39.8).

Item No.	Procedure		References
	Item	Normal condition or result	
1	SET: Inspect the equipment for preservation.	<ul style="list-style-type: none"> <li>a. Equipment must be externally clean and dry; free from grease, dirt, corrosion, and fungus.</li> <li>b. Painted surfaces must be free of bare spots, rust, and corrosion.</li> </ul>	<ul style="list-style-type: none"> <li>a. Par. 39.4.</li> <li>b. TM 9-213 and par. 39.4e.</li> </ul>
4	MOUNTING AND RACK: Inspect seating and stability of the mounting and rack. Check for loose or missing hardware.	All bolts, nuts, and washers are present and properly tightened. Mounting and rack show no evidence of weakness or deformity.	Par. 35e and f and applicable aircraft technical manual.
5	CONNECTIONS: Check all intercomponent cabling and wiring connections for cuts, kinks, breaks, fraying and undue strain.	All cables, connectors, and connections are clean, intact, and not loose-fitting.	Applicable aircraft technical manual.
7	ANTENNA: Inspect the antenna for: <ul style="list-style-type: none"> <li>a. Dirt -----</li> <li>b. Damage -----</li> </ul>	<ul style="list-style-type: none"> <li>a. Antenna drainage ducts are free from dirt and free to drain accumulated moisture.</li> <li>b. Dipoles are not bent or corroded. Antenna mounting must be secured to airframe.</li> </ul>	Par. 35a.

### 39.7. Periodic Maintenance Service and Inspection

Periodic maintenance on Receiving Sets, Radio AN/ARN-30D and AN/ARN-30E will be scheduled in accordance with the requirements of TM 38-750. The equipment will normally be part of an aircraft installation. The periodic maintenance inspection should be scheduled concurrently with the periodic maintenance service schedule out-of-service time to a minimum. Refer to the applicable aircraft technical manual for the hours between service periods. All deficiencies or shortcomings will

be immediately reported to a higher echelon by use of forms and procedures specified in TM 38-750. Equipment that has a deficiency that cannot be corrected by second echelon should be deadlined in accordance with TM 38-750. Perform all the services listed in the periodic maintenance inspection chart in the sequence listed. Whenever a *normal condition or result* is not observed, take corrective action in accordance with the *references*.

Note. The periodic maintenance and inspection is performed by an Aviation Electronic Equipment Repairman, MOS 284.1.

### 39.8. Periodic Maintenance Service and Inspection Chart

Item No.	Procedure		References
	Item	Normal condition or result	
1	SET: Inspect the equipment for: <ul style="list-style-type: none"> <li>a. Completeness -----</li> <li>b. Mounting -----</li> <li>c. Cleanliness -----</li> <li>d. Preservation -----</li> </ul>	<ul style="list-style-type: none"> <li>a. Equipment must be complete-----</li> <li>b. Equipment must be securely mounted with safety wiring attached where applicable.</li> <li>c. Equipment must be clean and dry, free from dust, dirt, and grease.</li> <li>d. Painted surfaces must be free of bare spots, rust, and corrosion. All decals, stencils, and other insignia must be legible.</li> </ul>	<ul style="list-style-type: none"> <li>a. Applicable aircraft manual.</li> <li>b. Par. 35 and TM 11-530.</li> <li>c. Par. 29.4.</li> <li>d. Par. 39.4 and TM 9-213.</li> </ul>

### 39.8. Periodic Maintenance Service and Inspection Chart—(Continued)

Item No.	Procedure		References
	Item	Normal condition or result	
2	PUBLICATIONS: See that pertinent publications are available.	<p>a. This technical manual must be complete and in usable condition without missing pages.</p> <p>b. All Changes pertinent to the equipment are on hand.</p> <p>c. Organizational maintenance manual is complete and in usable condition.</p>	<p>a. App. I.</p> <p>b. DA Pam 310-4 for requirements.</p> <p>c. None.</p>
3	MODIFICATION WORK ORDERS: Check DA Pam 310-4 to determine if new applicable MWO's have been published.	All URGENT MWO's have been applied to the equipment. All ROUTINE MWO's have been scheduled. MWO stencils must be legible.	Par. 35e and f.
4	MOUNTING AND RACK: Inspect seating and stability of mounting and rack. Check for loose or missing hardware.	All bolts, nuts, and washers are present and properly tightened. Mounting and rack show no evidence of weakness or deformity. Shock mounts must be free from deterioration and the rubber on the vibration absorbers must be in good condition.	
5	CONNECTIONS: Check all intercomponent cables, connectors, and connections.	All cables, connectors, and connections are clean, intact, and not loose-fitting. All safety wiring to connectors must be secure.	Applicable aircraft technical manual. Refer to TM 11-530 for safety wiring procedures.
6	KNOBS, DIALS, AND SWITCHES: Check for proper mechanical action by setting each control to each of its possible settings. NO CONTROL CHECK IS MADE ON THE CONVERTER, the controls are set and locked during alignment.	Action is positive and smooth. There is no evidence of binding or scraping. (Upon completion of the checks, return all controls to their <i>off</i> positions.)	Par. 35b, c, and d, and applicable aircraft technical manual. Knobs that require frequent tightening should have their set-screws replaced.
7	ANTENNA: a. Installation -----  b. Dirt -----	<p>a. Antenna is complete and properly installed, all bolts are secure.</p> <p>b. Antenna drainage ducts are free from dirt and free to drain accumulated moisture.</p> <p>c. Dipoles are not bent or corroded.</p>	Par. 35a.
8	OPERATIONAL CHECK. Perform a complete operational check.	Equipment operates in accordance with referenced operating instructions.	Par. 41.

## APPENDIX I REFERENCES

Following is a list of references available to the operator and organizational maintenance repairman of the vhf navigation set:

DA Pam 310-4	Index of Technical Manuals, Technical Bulletins, Supply Bulletins, Lubrication Orders, and Modification Work Orders.
TM 9-213	Painting Instructions for Field Use.
TM 11-530	Installation Practices for Aircraft Electric and Electronic Wiring.
TM 11-6625-203-12	Operation and Organizational Maintenance, Multimeter AN/URM-105, including Multimeter ME-77/U.
TM 38-750	The Army Equipment Record System and Procedures.

By Order of the Secretary of the Army:

Official:

**J. C. LAMBERT,**  
*Major General, United States Army,*  
*The Adjutant General.*

**EARLE G. WHEELER,**  
*General, United States Army,*  
*Chief of Staff.*

Distribution:

To be distributed in accordance with DA Form 12-31 requirements for Operators and Crew Members Instructions for all fixed and rotor wing aircraft.



MEMORANDUM FOR THE RECORD

Organization of the Department

Chief of Staff

and Executive

Procedure

General  
Chief of Staff

1. The Department is organized as follows:

2. The Chief of Staff is the principal advisor to the Secretary of Defense and is responsible for the coordination of the Department's operations.

3. The Department is organized into the following offices:

4. The Department's operations are conducted in accordance with the following procedures:

5. The Department's operations are conducted in accordance with the following procedures:

6. The Department's operations are conducted in accordance with the following procedures:

7. The Department's operations are conducted in accordance with the following procedures:

8. The Department's operations are conducted in accordance with the following procedures:



**TECHNICAL MANUAL**

**Operator and Organizational Maintenance Manual**

**RECEIVING SET, RADIO AN/ARN-30D AND AN/ARN-30E**

TM 11-5826-215-12

CHANGES No. 2

HEADQUARTERS,  
DEPARTMENT OF THE ARMY  
WASHINGTON 25, D.C., 17 September 1962

TM 11-5826-215-12, 21 August 1961, is changed as follows:

what Changes to or revisions of this publication are current.

Page 5, paragraph 2. Delete subparagraph *d* and substitute the following:

Page 39. APPENDIX I. REFERENCES. Add the following:

*d. Parts Lists Form.* Forward DA Form 2028 (Recommended Changes to DA Technical Manual Parts Lists or Supply Manuals 7, 8, and 9) direct to the Commanding Officer, U.S. Army Signal Materiel Support Agency, ATTN: SIGMS-ML, Fort Monmouth, N.J., with comments on Appendix II and Appendix III.

Additional instructions concerning maintenance of this equipment are contained in the following publication:

Field and Depot Maintenance Repair Parts and Special Tools List and Maintenance Allocation Chart:

Add paragraph 2.1 after paragraph 2.

TM 11-5826-220-35P, Power Supply PP-2792/ARN-30D; Power Supply, ARC Type DV-10A (PT/DWG 19840).

**2.1. Index of Equipment Publications**

Pages 40 thru 49. Appendix II and Appendix III. Delete and substitute the following:

Refer to DA Pamphlet 310-4 to determine

**APPENDIX II (SUPERSEDED)**

**MAINTENANCE ALLOCATION**

**Section I. INTRODUCTION**

**1. General**

*a.* This section assigns maintenance functions to be performed on components, assemblies, and subassemblies by the lowest appropriate maintenance echelon.

*b.* Columns in the maintenance allocation chart are as follows:

- (1) *Component.* This column shows only the nomenclature or standard item name. Additional descriptive data is included only where clarification is necessary to identify the component. Components, assemblies, and subas-

semblies are listed in topdown order. That is, the assemblies which are part of a component are listed immediately below that component, and the subassemblies which are part of an assembly are listed immediately below that assembly. Each generation break-down (components, assemblies, or sub-assemblies) are listed in disassembly order or alphabetical order.

- (2) *Maintenance function.* This column indicates the various maintenance functions allocated to the echelons.

PROPERTY OF THE TECHNICAL LIBRARY  
DO NOT REMOVE FROM BUILDING

Copy!

- (a) *Service*. To clean, to preserve, and to replenish lubricants.
- (b) *Adjust*. To regulate periodically to prevent malfunction.
- (c) *Inspect*. To verify serviceability and to detect incipient electrical or mechanical failure by scrutiny.
- (d) *Test*. To verify serviceability and to detect incipient electrical or mechanical failure by use of special equipment such as gages, meters, etc.
- (e) *Replace*. To substitute serviceable components, assemblies, or subassemblies, for unserviceable components, assemblies, or subassemblies.
- (f) *Repair*. To restore an item to serviceable condition through correction of a specific failure or unserviceable condition. This function includes but is not limited to welding, grinding, riveting, straightening, and replacement of parts other than the trial and error replacement of running spare type items such as fuses, lamps, or electron tubes.
- (g) *Align*. To adjust two or more components of an electrical system so that their functions are properly synchronized.
- (h) *Calibrate*. To determine, check, or rectify the graduation of an instrument, weapon, or weapons system, or components of a weapons system.
- (i) *Overhaul*. To restore an item to *completely serviceable* condition as prescribed by serviceability standards developed and published by heads of technical services. This is accomplished through employment of the technique of "Inspect and Repair Only as Necessary" (IROAN). Maximum utilization of diagnostic and test equipment is combined with minimum disassembly of the item during the overhaul process.
- (j) *Rebuild*. To restore an item to a standard as near as possible to original or new condition in appearance, performance, and life expectancy. This is accomplished through the maintenance technique of complete

disassembly of the item, inspection of all parts or components, repair or replacement of worn or unserviceable elements using original manufacturing tolerances and/or specifications, and subsequent reassembly of the item.

- (3) *1st, 2d, 3d, 4th, and 5th echelon*. The symbol X indicates the echelon responsible for performing that particular maintenance operation, but does not necessarily indicate that repair parts will be stocked at that level. Echelons higher than the echelon marked by X are authorized to perform the indicated operation.
- (4) *Tools required*. This column indicates codes assigned to each individual tool equipment, test equipment, and maintenance equipment referenced. The grouping of codes in this column of the maintenance allocation chart indicates the tool, test, and maintenance equipment required to perform the maintenance function.
- (5) *Remarks*. Entries in this column will be utilized when necessary to clarify any of the data cited in the preceding columns.

c. Columns in the allocation of tools for maintenance functions are as follows:

- (1) *Tools required for maintenance functions*. This column lists tools, test, and maintenance equipment required to perform the maintenance functions.
- (2) *1st, 2d, 3d, 4th, and 5th echelon*. The dagger (†) symbol indicates the echelons normally allocated the facility.
- (3) *Tool code*. This column lists the tool code assigned.

## 2. Maintenance by Using Organizations

When this equipment is used by signal services organizations organic to theater headquarters or communication zones to provide theater communications, those maintenance functions allocated up to and including fourth echelon are authorized to the organization operating this equipment.

## SECTION II MAINTENANCE ALLOCATION CHART

(1)	(2)	(3)	(4)	(5)	(6)	(7)	(8)	(9)
PART OR COMPONENT	MAINTENANCE FUNCTION	1ST ECH	2ND ECH	3RD ECH	4TH ECH	5TH ECH	TOOLS REQUIRED	REMARKS
RECEIVING SET RADIO AN/ARN-30D,E	service		X				27, 28	External
	adjust			X			7, 8, 27, 28	
	inspect		X					External
	test		X				27, 28 14, 29	
	test			X			2, 4, 7, 8, 9, 10, 11, 15, 16, 18, 19, 21, 24, 25, 26, 30	
	test				X		1, 2, 5, 6, 7, 8, 9, 10, 11, 15, 16, 18, 22, 24, 25, 26, 30	
	test					X	1 thru 13 15 thru 18 20, 22, 23, 25, 26, 30, 31	
	replace		X				29	
	repair				X		27, 28	
	align				X		2, 4, 9, 10, 11, 15, 16, 18, 19, 21, 25, 30	
	rebuild					X	2, 5, 6, 9, 10, 11, 15, 16, 30 27, 28	
	ANTENNA AS-580A/ARN-30	service		X				
inspect			X					External
test			X				27, 28 14	
replace			X				29	
repair				X			27, 28	
rebuild						X	27, 28	
CONTROL RADIO SET C-3436/ARN-30D	service		X					External
	inspect		X		X			Lubricate
	test		X		X			External
	test		X		X			Operational
	replace		X				11, 16, 25 29	At 5th echelon add code 3
	repair			X			27, 28	
	rebuild						X	27, 28

NAVY-200'S

(1) PART OR COMPONENT	(2) MAINTENANCE FUNCTION	(3) 1ST ECH.	(4) 2ND ECH.	(5) 3RD ECH.	(6) 4TH ECH.	(7) 5TH ECH.	(8) TOOLS REQUIRED	(9) REMARKS
AN/ARN-30D,E (continued)								
CONTROL, RADIO SET C-3436A/ARN-30D	service		X					External
	inspect			X				Lubricate External
	test		X	X				Operational
	replace			X			11,16,25	At 5th echelon add code 3
	repair rebuild			X	X		29 27,28 27,28	
CONVERTER, SIGNAL DATA CV-265A/ARN-30A	service		X				27,28	External
	adjust			X			7,8,27,28	Relay adjustment
	inspect		X					External
	test		X	X			27,28	Operational
	test			X			11,15,16,24,25	At 5th echelon delete code 25 Add code 23 and code 3
	replace repair algin rebuild			X	X		29 27,28 11,15,16,25,30 27,28	
INDICATOR ID-453/ARN-30	service		X					External
	inspect		X					External
	test			X			11,25	
	test					X	3,12,13,17,20, 30,31	
	replace repair rebuild			X	X		29 27,28 27,28	
MOUNTING MT-1174/ARN-30A	service		X					
	inspect		X					
	replace		X				29	
	repair			X			27,28	
	rebuild					X	27,28	

(1) PART OR COMPONENT	(2) MAINTENANCE FUNCTION	(3) 1ST ECH.	(4) 2ND ECH.	(5) 3RD ECH.	(6) 4TH ECH.	(7) 5TH ECH.	(8) TOOLS REQUIRED	(9) REMARKS
AN/ARN-30D,E (continued)								
MOUNTING MT-1175/ARN-30A	service		X					External
	adjust			X			7, 8, 27, 28	Relay adjustment
	inspect		X		X			External
	test				X		11, 16, 25	
	replace			X			29	
	repair rebuild				X		27, 28 27, 28	
POWER SUPPLY PP-2792/ARN-30D AND POWER SUPPLY, ARC TYPE DV-10A (P/DWG 19840)	replace		X					See seperate MAC
PRINTED CIRCUIT, AF	replace			X			27, 28	
PRINTED CIRCUIT, IF	repair				X		27, 28	
PRINTED CIRCUIT, IF	repair				X		27, 28	
RECEIVER RADIO R-1021/ARN-30D	service		X				27, 28	External
RECEIVER RADIO R-1021/ARN-30D	inspect		X	X			27, 28	External
RECEIVER RADIO R-1021/ARN-30D	test			X	X		2, 4, 9, 10, 11, 15,	
RECEIVER RADIO R-1021/ARN-30D	test						16, 18, 19, 21, 24,	
RECEIVER RADIO R-1021/ARN-30D	test					X	25, 30	
RECEIVER RADIO R-1021/ARN-30D	test						1, 2, 5, 6, 9, 10, 11,	
RECEIVER RADIO R-1021/ARN-30D	test					X	15, 16, 18, 24, 25, 30	
RECEIVER RADIO R-1021/ARN-30D	test						1, 2, 3, 5, 6, 9, 10, 11,	
RECEIVER RADIO R-1021/ARN-30D	test						12, 15, 16, 18, 23,	
RECEIVER RADIO R-1021/ARN-30D	replace			X			25, 30	
RECEIVER RADIO R-1021/ARN-30D	repair				X		29	
RECEIVER RADIO R-1021/ARN-30D	align				X		27, 28	
RECEIVER RADIO R-1021/ARN-30D	align				X		4, 9, 10, 11, 18, 19,	
RECEIVER RADIO R-1021/ARN-30D						X	21, 25, 30	
RECEIVER RADIO R-1021/ARN-30D						X	5, 6, 9, 10, 11, 15,	

(1)	(2)	(3)	(4)	(5)	(6)	(7)	(8)	(9)
PART OR COMPONENT	MAINTENANCE FUNCTION	1ST ECH.	2ND ECH.	3RD ECH.	4TH ECH.	5TH ECH.	TOOLS REQUIRED	REMARKS
AN/ARN-30D,E (continued)								
CONTROL, RADIO SET C-3436A/ARN-30D	service		X					External
	inspect			X				Lubricate
	test			X				External
	replace			X			11,16,25	Operational
	repair			X			29	At 5th echelon add code 3
CONVERTER, SIGNAL DATA CV-265A/ARN-30A	rebuild			X			27,28	
	service		X				27,28	External
	adjust			X			7,8,27,28	Relay adjustment
	inspect		X				27,28	External
	test		X				27,28	Operational
INDICATOR ID-453/ARN-30	test			X			11,15,16,24,25	At 5 th echelon delete code 25
	replace		X				29	Add code 23 and code 3
	repair			X			27,28	
	algin			X			11,15,16,25,30	
	rebuild					X	27,28	
MOUNTING MT-1174/ARN-30A	service		X					External
	inspect		X					External
	test			X			11,25	
	test					X	3,12,13,17,20, 30,31	
	replace		X				29	
MOUNTING MT-1174/ARN-30A	repair			X			27,28	
	rebuild					X	27,28	
	service		X					
	inspect		X					
	replace		X				29	
MOUNTING MT-1174/ARN-30A	repair			X			27,28	
	rebuild					X	27,28	
	service		X					



(1)	(2)	(3)	(4)	(5)	(6)	(7)	(8)	(9)	
PART OR COMPONENT	MAINTENANCE FUNCTION	1ST ECH.	2ND ECH.	3RD ECH.	4TH ECH.	5TH ECH.	TOOLS REQUIRED	REMARKS	
AN/ARN-30D,E (continued)									
MOUNTING MT-1175/ARN-30A	service		X					External	
	adjust			X			7,8,27,28	Relay adjustment	
	inspect		X					External	
	test			X			11,16,25		
	replace			X			29		
	repair rebuild				X		27,28 27,28		
POWER SUPPLY PP-2792/ARN-30D AND POWER SUPPLY, ARC TYPE DV-10A (P/DWG 19840)	replace		X					See separate MAC	
PRINTED CIRCUIT, AF	replace			X			27,28		
	repair				X		27,28		
PRINTED CIRCUIT, IF	replace			X			27,28		
	repair					X	27,28		
RECEIVER RADIO R-1021/ARN-30D	service		X		X		27,28	External	
	inspect		X				27,28	External	
	test				X		2,4,9,10,11,15, 16,18,19,21,24, 25,30		
	test					X	1,2,5,6,9,10,11, 15,16,18,24,25,30		
	test					X	1,2,3,5,6,9,10,11, 12,15,16,18,23, 25,30		
	replace			X			29		
	repair				X		27,28		
	align				X		4,9,10,11,18,19, 21,25,30		
							X	5,6,9,10,11,15, 16,18,25,30	
	rebuild						X	27,28	

## SECTION III ALLOCATION OF TOOLS FOR MAINTENANCE FUNCTIONS

(1)	(2)	(3)	(4)	(5)	(6)	(7)	(8)
TOOLS REQUIRED FOR MAINTENANCE FUNCTIONS	1ST ECH.	2ND ECH.	3RD ECH.	4TH ECH.	5TH ECH.	TOOL CODE	REMARKS
AN/ARN-30D,E (continued)							
ANALYZER, SPECTRUM TS-723/U				+	+	1	
AUDIO OSCILLATOR TS-382/U			+	+	+	2	
COURCE CHECKER (A.R.C. type R-16, or equal)					+	3	
FREQUENCY METER AN/URM-32			+			4	
FREQUENCY METER AN/URM-79				+	+	5	
FREQUENCY METER AN/URM-81				+	+	6	
GAGE TL-558/U			+	+	+	7	
GAGE TL-559/U			+	+	+	8	
GENERATOR SIGNAL AN/USM-44			+	+	+	9	
HEADSET HS-33 (or equiv)			+	+	+	10	
MAINTENANCE KIT ELECTRONIC EQUIPMENT MK-252/ARN			+	+	+	11	Plus adapter kit ARC No. 27452
METER TEST SET TS-682( )/GSM-1					+	12	
MODULATOR MD-83/ARN					+	13	
MULTIMETER AN/URM-105		+				14	
MULTIMETER ME-26/U			+	+	+	15	
MULTIMETER TS-352/U			+	+	+	16	
OHMMETER ZM-21/U				+	+	17	
POWER SUPPLY PP-1104/B			+	+	+	18	
POWER SUPPLY PP-1243/U			+			19	
RESISTANCE BRIDGE ZM-4/U					+	20	
SIGNAL GENERATOR SG-13/ARN			+			21	
TEST SET I-199				+	+	22	
TEST SET ELECTRON TUBE TV-2/U					+	23	
TEST SET ELECTRON TUBE TV-7/U			+	+		24	
TEST SET RADIO AN/ARN-5			+	+	+	25	
TEST SET TRANSISTOR			+	+	+	26	In development
TOOL KIT TK-87/U			+	+	+	27	Use TE-114 until available
TOOL KIT TK-88( )/U			+	+	+	28	Use TE-114 until available
TOOL KIT TK-115/U		+				29	Use TE-41 until available
VOLTMETER METER ME-30/U			+	+	+	30	
FRQUENCY METER AN/USM-26					+	31	

APPENDIX III (SUPERSEDED)

BASIS ISSUE ITEMS LIST

Section I. INTRODUCTION

1. Scope

This appendix lists items supplied for initial operation. The list includes tools, parts, and material issued as part of the major end item. The list includes all items authorized for basic operator maintenance of the equipment. End items of equipment are issued on the basis of allowances prescribed in equipment authorization tables and other documents that are a basis for requisitioning.

2. Columns

- a. *Source, maintenance, and recoverability code.* Not used.
- b. *Federal stock number.* This column lists the 11-digit Federal stock number.
- c. *Designation by model.* The dagger (†) indicates model in which the part is used.

d. *Description.* Nomenclature or the standard item name and brief identifying data for each item are listed in this column. When requisitioning, enter the nomenclature and description.

e. *Unit of issue.* The unit of issue is each unless otherwise indicated and is the supply term by which the individual item is counted for procurement, storage, requisitioning, allowances, and issue purposes.

f. *Expendability.* Nonexpendable items are indicated by NX. Expendable items are not annotated.

g. *Quantity authorized.* Under "Items Comprising an Operable Equipment," the column lists the quantity of items supplied for the initial operation of the equipment.

h. *Illustration.* The Item No. column lists the reference symbols used for identification of the items in the illustration or text of the manual.

## SECTION II FUNCTIONAL PARTS LIST

(1) SOURCE MAINTENANCE AND RECOVERABILITY CODE	(2) FEDERAL STOCK NUMBER	(3) DESIGNATION BY MODEL				(4) DESCRIPTION	(5) UNIT OF ISSUE	(6) EXPENDABILITY	(7) QUANTITY AUTHORIZED	(8) ILLUSTRATIONS		(9)
										FIGURE NO	ITEM NO.	
	5826-752-5814	1	2			RECEIVING SET RADIO AN/ARN-30D: 1 band, 180-126.90 mc freq range, 190 channels; 28 vdc, rack mts ARC type 15F		NX				
	5826-892-1056					RECEIVING SET, RADIO AN/ARN-30E: 1 band, 108-126.90 mc freq range, 190 channels, 28 vdc, rack mts, ARC type 15F		NX				
						NOTE: Model Column 1 refers to AN/ARN-30D; Column 2 refers to AN/ARN-30E						
						ITEMS COMPRISING AN OPERABLE EQUIPMENT						
	Ord thru AGC	+	+			TECHNICAL MANUAL: TM 11-5826-215-12			2			
	5985-270-8399	+	+			ANTENNA AS-580A/ARN-30: ramshorn type; for receiving VHF; ARC type A-13B		NX	1			
	5935-195-4066	+	+			CONNECTOR, PLUG, ELECTRICAL UG-88C/U: single rd female cont; straight			2		P1301	
	5935-258-5828	+	+			CONNECTOR, PLUG, ELECTRICAL: 2 rd female cont; banana type; ARC part/dwg No. 14321			1		P1304	
	5935-549-7486	+	+			CONNECTOR, PLUG, ELECTRICAL: 6 female cont; banana type; ARC part/dwg No. 15911			1		P1307	
	5935-549-7487	+	+			CONNECTOR, PLUG, ELECTRICAL: 8 female cont; banana type; ARC part/dwg No. 15912			1		P1305	
	5935-295-5438	+	+			CONNECTOR, PLUG, ELECTRICAL: 8 rd female cont; straight; ARC part/dwg No. 14050			2		P1303 P1306	
	5935-678-8491	+	+			CONNECTOR, PLUG, ELECTRICAL: 8 rd female cont; straight; ARC part/dwg No. 16210			1			
	5935-257-8311	+	+			CONNECTOR, PLUG, ELECTRICAL: 19 rd female cont; locking type; ARC part/dwg No. 14320			1			
	5935-549-4212	+	+			CONNECTOR, PLUG, ELECTRICAL: 19 cont; straight; ARC part/dwg No. 16115			2			
	5826-752-5735	+				CONTROL, RADIO SET C-3436/ARN-30D; 28vdc; 126.90 mc max range; ARC type C-81A		NX	1			
	5826-892-1061	+				CONTROL, RADIO SET C-3436A/ARN-30D; 28v dc, 108 to 126.90 mc max range; ARC type C-88A		NX	1			
	5826-505-0645	+	+			CONVERTER, SIGNAL DATA CV-265A/ARN-30A: converter output indicated on external meters; ARC type B-13A-1		NX	1			
	5826-697-9880	+	+			INDICATOR, COURSE ID-453/ARN-30: combined cross-pointer meter To-From meter and course selector ARC type IN-10		NX	1			

(1) SOURCE MAINTENANCE AND RECOVERABILITY CODE	(2) FEDERAL STOCK NUMBER	(3) DESIGNATION BY MODEL				(4) DESCRIPTION	(5) UNIT OF ISSUE	(6) EXPENDABILITY	(7) QUANTITY AUTHORIZED	(8) (9) ILLUSTRATIONS	
		1	2							FIGURE NO	ITEM NO
	6625-091-0494	+	+			AN/ARN-30D,E (continued)					
	5826-611-0865	+	+			MOUNTING MT-1174/ARN-30A: aluminum; ARC type M-10		NX	1		
	5826-752-2508	+	+			MOUNTING MT-1175/ARN-30A: aluminum; ARC type E-14		NX	1		
						POWER SUPPLY PP-2792/ARN-30D: crystal rectifier; full wave; ARC type DV-10A		NX	1		
						OR					
	5821-542-7937	+	+			POWER SUPPLY: ARC type DV-10A: rectifier type; 26v ac, ARC part/dwg No. 19840		NX	1		
	6145-542-6092	+	+			RADIO FREQUENCY CABLE RG-58C/U: (NOTE: Authorized quantity will be a minimum or a multiple of 20 ft)	ft		20	W301	
	5826-752-5730					RECEIVER RADIO R-1021/ARN-30D: 1 band, 108-126.90 mc, 190 channels; ARC type R-34A (28v)		NX	1		
						RUNNING SPARES AND ACCESSORY ITEMS					
						NO PARTS AUTHORIZED FOR STOCKAGE AT FIRST ECHELON					

BY ORDER OF THE SECRETARY OF THE ARMY:

G. H. DECKER,  
*General, United States Army,*  
*Chief of Staff.*

Official:

J. C. LAMBERT,  
*Major General, United States Army,*  
*The Adjutant General.*

Distribution:

To be distributed in accordance with DA Form 12-31 requirements for Organizational Maintenance Instructions for all fixed and rotor wing aircraft.

X



TM 11-5826-215-12 RECEIVING SET, RADIO AN/ARN-30D-1961