

NASA WORKMANSHIP STANDARDS

PICTORIAL REFERENCE

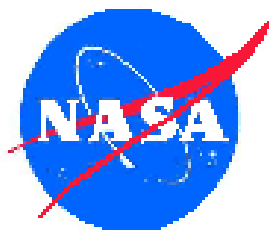

National Aeronautics and
Space Administration

Johnson Space Center
Houston, Texas USA 77058

INTRODUCTION

SECTION 1 WIRE PREPARATION

%20

- [1.01 - General Requirements](#)
- [1.02 - Mechanical Stripping](#)
- [1.03 - ELA and Thermal Stripping](#)
- [1.04 - Chemical Stripping](#)

SECTION 2 CRIMPED TERMINATIONS

- [2.01 - General Requirements](#)
- [2.02 - Crimp Pins & Sockets](#)
- [2.03 - Multiple Crimp Pins & Sockets](#)
- [2.04 - Blade/Pin Terminals](#)
- [2.05 - Ring Lug Terminals](#)
- [2.06 - Spade Lug Terminals](#)
- [2.07 - Butt Splices](#)
- [2.08 - End Splices](#)
- [2.09 - Parallel Splices](#)
- [2.10 - Shield Crimps](#)

SECTION 3 DISCRETE WIRING

- [3.01 - Solderless Wrapped Electrical Connections-Wire Wrap](#)
- [3.02 - Jumper Wires](#)
- [3.03 - Deadbugs](#)

SECTION 4 CABLES AND HARNESS

- [4.01 - General Requirements](#)
- [4.02 - Discrete Conductor](#)
- [4.03 - Multi-Conductor Cable](#)
- [4.04 - Coaxial Cable](#)
- [4.05 - Flat/Ribbon Cable](#)
- [4.06 - Solder Sleeves](#)
- [4.07 - Splices](#)

SECTION 5 PRINTED WIRING BOARD (PWB)

- [5.01 - General Requirements](#)
- [5.02 - Rigid Laminate](#)
- [5.03 - Flexible Laminate](#)
- [5.04 - Rigid-Flexible Laminate](#)

SECTION 6 THROUGH-HOLE SOLDERING (PWB)

- [6.01 - General Requirements](#)
- [6.02 - Preparation of Conductors](#)
- [6.03 - Mechanical Assembly-Hardware](#)
- [6.04 - Mechanical Assembly-Power Semiconductors & Heatsinks](#)
- [6.05 - Mechanical Assembly-Swaged Terminals](#)
- [6.06 - Mechanical Assembly-Component Support, Mechanical](#)
- [6.07 - Soldered Connectors](#)
- [6.08 - Solderless \(Press-Fit\) Connectors](#)
- [6.09 - Axial Components](#)
- [6.10 - Radial Components](#)
- [6.11 - Component Installation-Dual In-Line Packages \(DIPS\)](#)
- [6.12 - Single In-Line Package \(SIP\)](#)
- [6.13 - Terminals](#)

[6.14 - Solder Cups](#)

[6.15 - Discrete Wires](#)

[6.16 - Service Lead Splices](#)

[6.17 - High-Voltage Terminations](#)

SECTION 7 SURFACE MOUNT TECHNOLOGY (SMT)

[7.01 - General Requirements](#)

[7.02 - Solder Paste/Solder Preform Application](#)

[7.03 - Adhesive Application](#)

[7.04 - Chip Components/Bottom-Only Terminations](#)

[7.05 - Chip Components-Rectangular/Square End Terminations](#)

[7.06 - Metallized Electrode Face \(MELF\)](#)

[7.07 - Gull-Wing/"L" Leaded Packages](#)

[7.08 - Butt "I" Leaded Packages](#)

[7.09 - "J" Leaded Packages](#)

[7.10 - Inward-Formed "L" Leaded Packages](#)

[7.11 - Leaded Packages/Parts Round or Flattened \(Coined\) Leads.](#)

[7.12 - Leadless Chip Carriers \(LLCC\)](#)

[7.13 - Ball Grid Array \(BGA\)](#)

SECTION 8 CONFORMAL COATING AND STAKING (BONDING)

[8.01 - General Requirements](#)

[8.02 - Adhesive Bonding/Staking](#)

[8.03 - Conformal Coating](#)

SECTION 9 POLYMERIC SYSTEMS

[9.01 - General Requirements](#)

SECTION 10 FIBER OPTICS

[10.01 - General Requirements](#)

[10.02 - Fiber Optic Assemblies](#)

[10.03 - Fiber Optic Cable Assemblies](#)

SECTION 11 ELECTROSTATIC DISCHARGE (ESD)

[11.01 - General Requirements](#)

APPENDIX

DEFINITIONS

INTRODUCTION

The Inspectors Pictorial Reference provides full color visual examples of acceptance / rejection criteria which may be used for the design, manufacture and inspection of electrical / electronic equipment for high-reliability and space flight applications, and is a reference-only companion to the NASA Technical Standard, NASA-STD-8739 series of workmanship requirements documents.

ACCEPTANCE/ REJECTION CRITERIA

The following classification terms are used to identify acceptable and unacceptable workmanship conditions:

- * PREFERRED – A condition that is close to “perfect”.
- * MANDATORY – A hard requirement that must be met.
- * ACCEPTABLE – A condition that may not be perfect, but meets the requirement.
- * UNACCEPTABLE – Does not meet the minimum requirement and that may be insufficient to ensure the form, fit, or function of the hardware in its end use.

REQUIREMENT REFERENCES

Each Acceptance / Rejection Criteria example contains a reference to the applicable requirement(s) from the NASA Technical Standard Series, NASA-STD-8739.x. In instances where there is no specific requirement, the reference defaults to Best Workmanship Practice, which identifies a procedure, practice, or process attribute that has been demonstrated through use and experience, to result in a robust design and high reliability.

SPECIAL REQUIREMENTS

Special requirements may exist which are not covered by, or do not comply with, the visual examples depicted in this reference, and which are in conflict with the requirements specified in the NASA-STD-8739 series documents. Engineering documentation shall contain the details for such instances, and shall take precedence over appropriate sections of this reference and the requirements document.

CONTROL COPY NUMBER/DISTRIBUTION

Each Pictorial Reference is issued with a Control Copy Number, and all subsequent releases will be distributed in accordance with this numbering system. Each assignee will be required to remove and insert pages of each release in their assigned manual in accordance with instructions given on each release, to maintain an up-to-date and useful reference. Should an assignee no longer require a manual, it shall be returned to the Technology Division (NX) of Safety, Reliability, and Quality Assurance (SR&QA).

This document shall not be rewritten or reissued in any other form not approved by NASA.

ACKNOWLEDGEMENTS

The illustrations and photographs contained in this reference represent a compilation of workmanship and “best design practices” from currently used industrial, military, and NASA-approved workmanship standards, compiled from technical expert sources within NASA, and from the Association Connecting Electronics Industries (IPC).



[Need a printed copy?](#)
[\(May take a while to load.\)](#)
Requires Adobe Reader.

[Need Adobe Reader?](#)
[Click here to download.](#)

[Questions? Suggestions?](#)

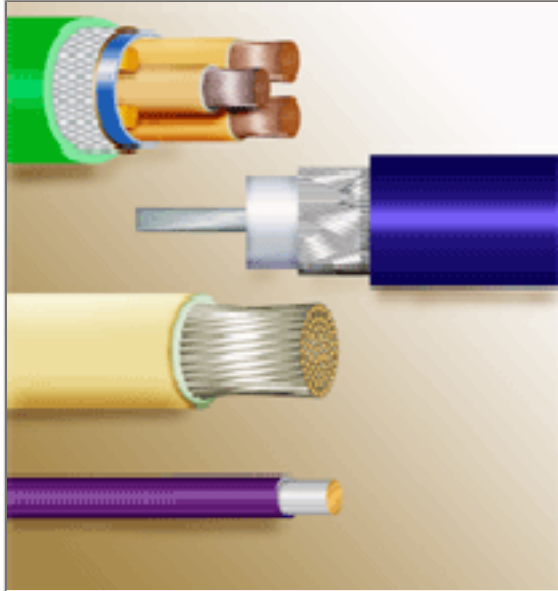
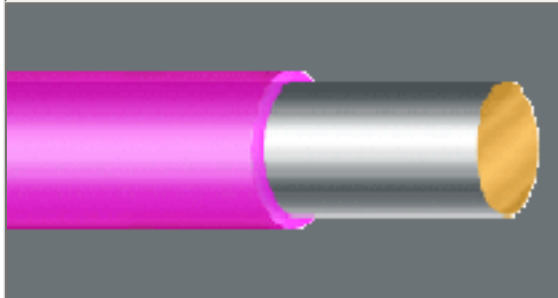
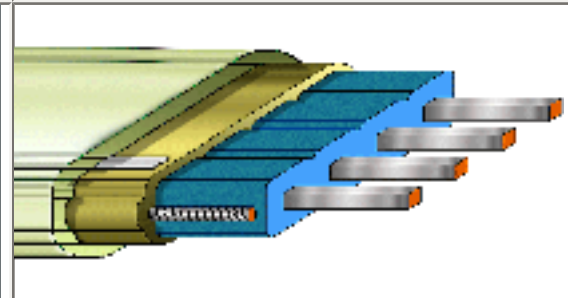
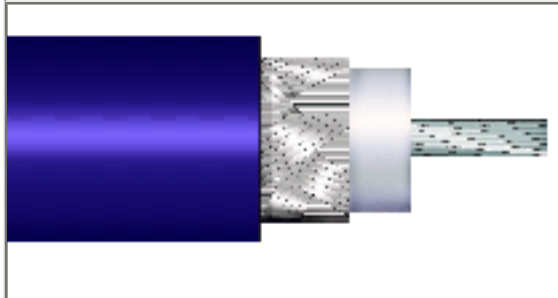
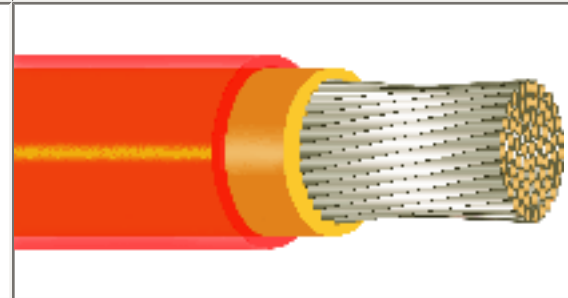
WIRE PREPARATION GENERAL REQUIREMENTS	
	<p style="text-align: center;"><u>WIRE PREPARATION GENERAL REQUIREMENTS</u></p> <p>Wire conductors are available in many forms, ranging from single, solid insulated conductors, to highly integrated, multiple conductor cables.</p> <p>Wires and cables can function as simple discrete jumpers on circuit boards, or woven into intricate harnesses that snake through a vehicle, functioning as the nervous system for the routing of command, control and signal impulses.</p> <p>The correct preparation of conductors will result in a termination of high quality and reliability.</p>
	
<p style="text-align: center;">PREFERRED CHEMICAL STRIPPING PROCESS</p> <p>The insulation jacket has been neatly removed, with no damage to the conductor or insulation. No wicking of stripper or cleaner agents evident.</p> <p><i>Note: Chemical stripping is suitable for solid conductors only.</i></p>	<p style="text-align: center;">PREFERRED FLAT CABLE</p> <p>The outer jacket, conductive shield (if supplied), and conductor insulation jackets have been neatly trimmed and removed, with minimal edge flash and no mechanical damage. The conductors are in planar orientation, and the drain conductor and/or shield are undamaged.</p>
	
<p style="text-align: center;">PREFERRED FLEXIBLE COAXIAL CABLE</p> <p>The insulation jacket and shield(s) have been neatly trimmed, with minimal edge flash and no mechanical damage to the conductors, shielding, dielectric or insulation jacket. The center conductor stranding exhibits a normal twist pattern (lay).</p>	<p style="text-align: center;">PREFERRED KAPTON® INSULATED CONDUCTORS</p> <p>Kapton®-insulated conductors must be trimmed neatly and squarely, with minimal edge flash and no mechanical damage to the conductor or insulation.</p>

NASA WORKMANSHIP STANDARDS

	Released: 03.31.2000	Revision: B	Revision Date: 07.03.2002
--	-------------------------	----------------	------------------------------



WIRE PREPARATION
 GENERAL REQUIREMENTS (cont.)

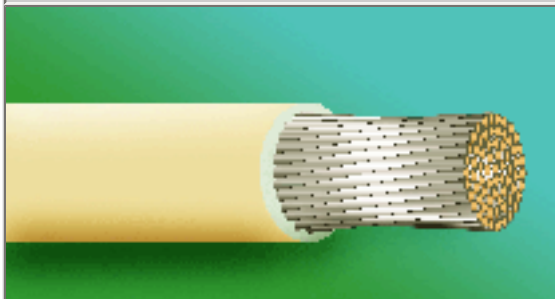

PREFERRED
 MECHANICAL STRIPPING PROCESS

The insulation jacket has been neatly trimmed, with minimal edge flash and no mechanical damage to the conductor or insulation. Conductor stranding lay (twist pattern) is undisturbed.

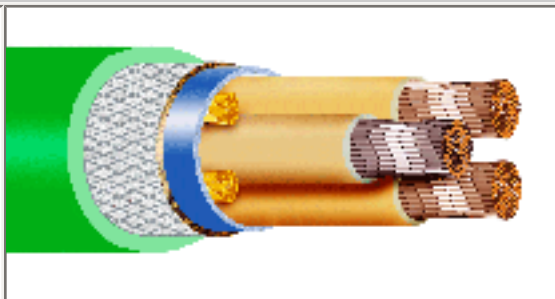

PREFERRED
 MULTI-CONDUCTOR CABLE

The outer jacket, shield, strength members and conductor insulation have been neatly trimmed and removed, with minimal edge flash and no mechanical damage. Conductor stranding lay (twist pattern) is undisturbed.

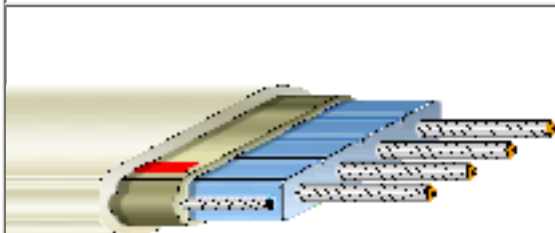

PREFERRED
 RIBBON CABLE

The outer jacket, conductive shield (if supplied), and conductor insulation have been neatly trimmed and removed, with minimal edge flash and no mechanical damage. The conductors are in normal planar orientation, and the drain conductor and/or shield are undamaged.

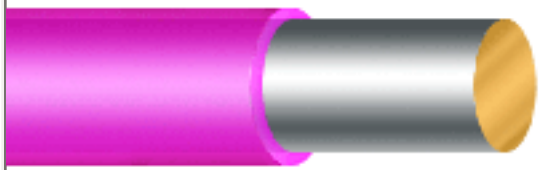

PREFERRED
 SOLID CONDUCTOR

The insulation jacket has been neatly trimmed, with minimal edge flash and no mechanical damage to the conductor or insulation. Chemical/thermal/laser-trimmed conductors may exhibit slight discoloration of the insulation jacket(s) at the trimmed edge.

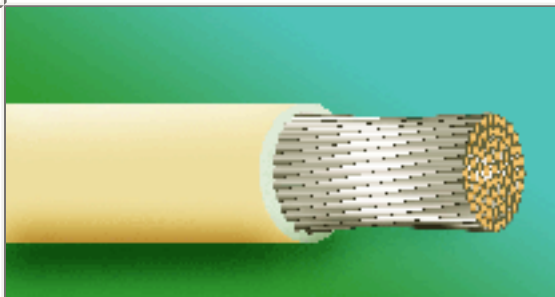
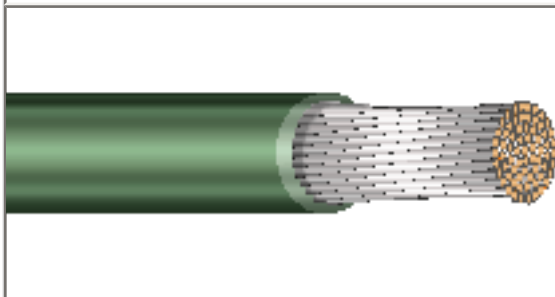

<p>PREFERRED STRANDED CONDUCTOR</p> <p>The insulation jacket has been neatly trimmed, with minimal edge flash and no mechanical damage to the conductor or insulation. Conductor stranding lay (twist pattern) is undisturbed.</p>	<p>PREFERRED THERMAL/ EXCIMER LASER STRIPPING</p> <p>The insulation jacket has been neatly trimmed, with minimal edge flash and no damage to the conductor or insulation. Slight discoloration of the insulation jacket(s) at the trimmed edge.</p>
---	--

NASA WORKMANSHIP STANDARDS

 <p>NATIONAL AERONAUTICS AND SPACE ADMINISTRATION JOHNSON SPACE CENTER HOUSTON, TEXAS USA 77058</p>	Released:	Revision:	Revision Date:
	03.31.2000	B	07.03.2002
	Book:	Section:	Page:
1	1.01	2	

**WIRE PREPARATION
GENERAL REQUIREMENTS (cont.)**

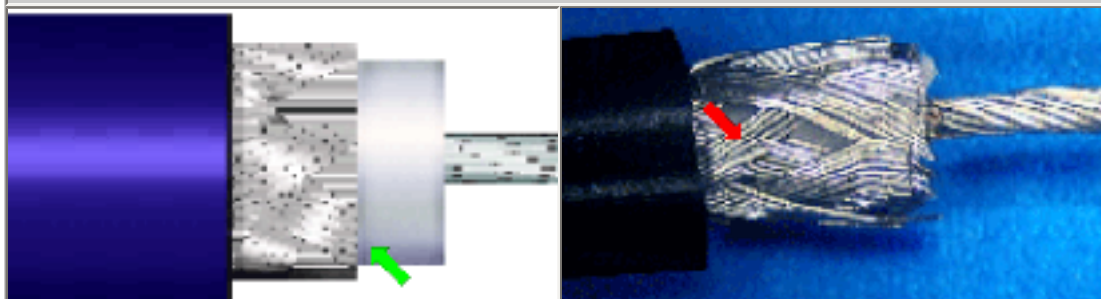

**ACCEPTABLE
BRAIDED SHIELD**

The shield has been properly stripped, evenly trimmed, and exhibits a fairly uniform coverage pattern (braid weave). No severed strands.

[NASA-STD-8739.4 \[10.2 \] \[19.6.1.a\]](#)

**UNACCEPTABLE
SEVERED SHIELD STRANDS**

Severed shield braid strands shall be cause for rejection.

[NASA-STD-8739.4 \[10.2 \] \[19.6.2.a.4 \]](#)

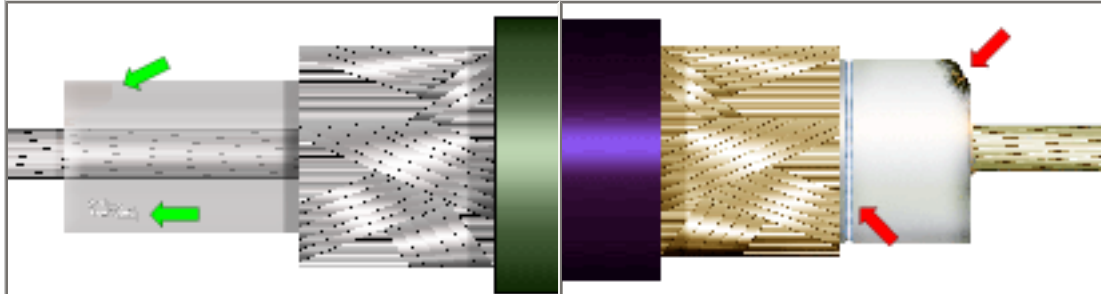

**ACCEPTABLE
DIELECTRIC**

The dielectric has been properly exposed, exhibiting a smooth, clean cut with minimal edge flash. Minor edge discoloration (due to thermal stripping) and/or surface scuffing is acceptable.

[NASA-STD-8739.3 \[7.2.2 \]](#)
[NASA-STD-8739.4 \[10.1.2 \]](#)

**UNACCEPTABLE
DIELECTRIC DAMAGE**

Coaxial cables with center conductors exhibiting damage to the dielectric (i.e.: burns, charring, cracks, crushing, cuts, deformation, necking, nicks, ringing, etc.) shall be rejected.

[>NASA-STD-8739.3 \[13.6.2.a.1 \]](#)
[NASA-STD-8739.4 \[10.1.2 \], \[19.6.2.a.1\]](#)

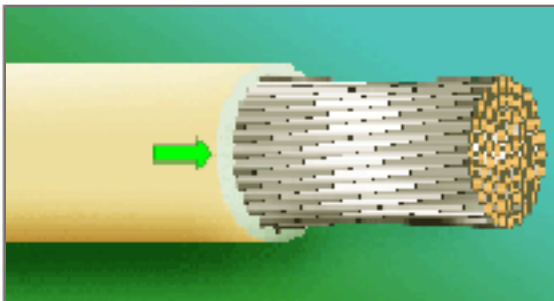
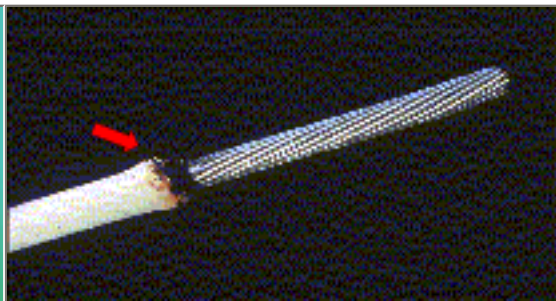
	
<p style="text-align: center;">ACCEPTABLE DISCOLORED INSULATION</p> <p>Slight discoloration of the insulation jacket(s) at the trimmed edge is acceptable. Evidence of burning or charring is not acceptable.</p> <p>NASA-STD-8739.3 [7.2.2] NASA-STD-8739.4 [10.1.2], [19.6.1.a.1]</p>	<p style="text-align: center;">UNACCEPTABLE BURNED/CHARRED/MELTED INSULATION</p> <p>Burned, charred, or melted insulation is an indicator of improper process controls and/or stripping procedures, resulting in embrittlement, reduced dielectric properties and reduced reliability.</p> <p>NASA-STD-8739.3 [13.6.2.a.1] NASA-STD-8739.4 [19.6.2.a.2]</p>

NASA WORKMANSHIP STANDARDS

 <p>NATIONAL AERONAUTICS AND SPACE ADMINISTRATION JOHNSON SPACE CENTER HOUSTON, TEXAS USA 77058</p>	<p>Released: 03.31.2000</p>	<p>Revision: B</p>	<p>Revision Date: 07.03.2002</p>
	<p>Book: 1</p>	<p>Section: 1.01</p>	<p>Page: 3</p>

**WIRE PREPARATION
GENERAL REQUIREMENTS (cont.)**

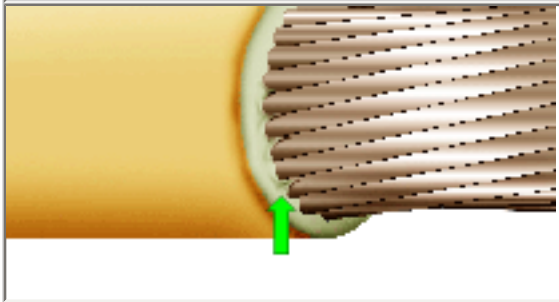
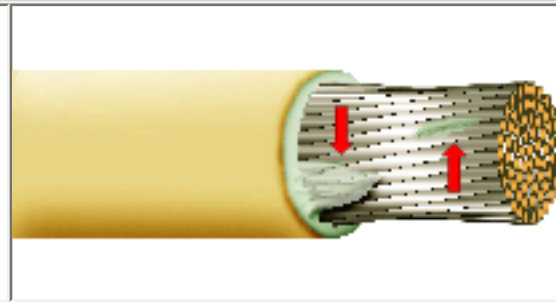
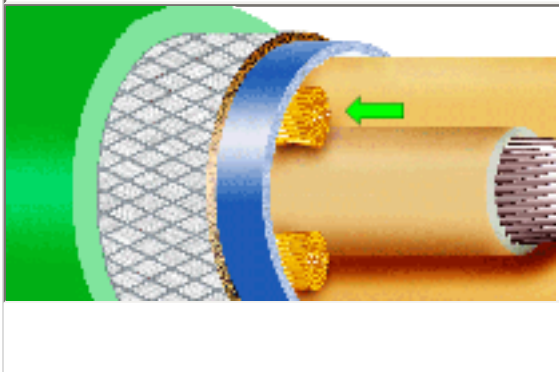
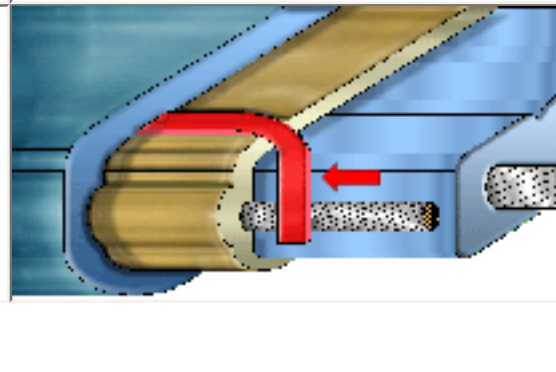
	
<p style="text-align: center;">ACCEPTABLE EDGE FLASH</p> <p>Edge flash shall not exceed one-quarter insulated wire diameter (1/4 d). Edge flash is considered a contaminant, which may interfere with crimped or soldered terminations.</p> <p>NASA-STD-8739.4 [10.1.6]</p>	<p style="text-align: center;">UNACCEPTABLE EDGE FLASH/SMEARING</p> <p>The edge flash is in excess of one-quarter insulated wire diameter (1/4 d), and the stripped section exhibits smearing (melted insulation/film) which is considered a contaminant.</p> <p>NASA-STD-8739.4 [10.1.6]</p>
	

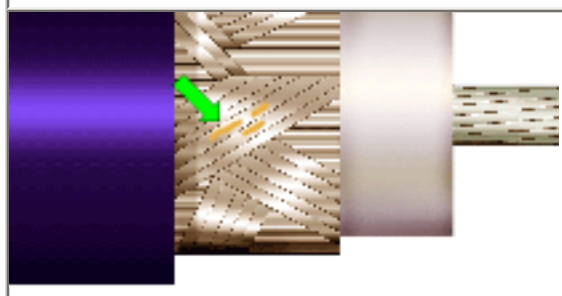
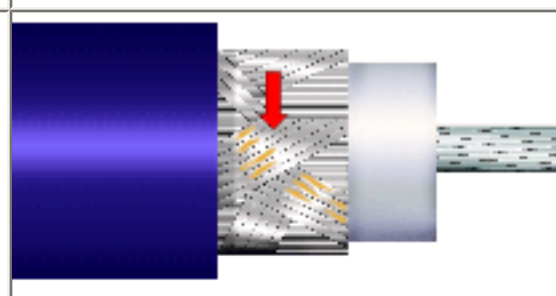

<p style="text-align: center;">ACCEPTABLE ID RIBBON/STRENGTH MEMBER</p> <p>The identification ribbon and/or strength member should be trimmed back to the insulation to prevent its inclusion into a soldered or crimped termination.</p> <p>Best Workmanship Practice</p>	<p style="text-align: center;">UNACCEPTABLE UNTRIMMED ID RIBBON/STRENGTH MEMBER</p> <p>The identification ribbon and/or strength member has not been trimmed properly, which can interfere with the proper assembly of the soldered or crimped termination.</p> <p>Best Workmanship Practice</p>
	
<p style="text-align: center;">ACCEPTABLE NICKED SHIELD STRANDS</p> <p>Nicked shield strands shall not exceed 10% of the total number of strands.</p> <p>NASA-STD-8739.4 [10.2] [19.6.1.3]</p>	<p style="text-align: center;">UNACCEPTABLE NICKED SHIELD STRANDS</p> <p>The number of nicked shield strands is in excess of 10% of the total number of strands.</p> <p>NASA-STD-8739.4 [10.2], [19.6.2.b.2]</p>

NASA WORKMANSHIP STANDARDS

 <p>NATIONAL AERONAUTICS AND SPACE ADMINISTRATION JOHNSON SPACE CENTER HOUSTON, TEXAS USA 77058</p>	<p>Released: 03.31.2000</p>	<p>Revision: B</p>	<p>Revision Date: 07.03.2002</p>
	<p>Book: 1</p>	<p>Section: 1.01</p>	<p>Page: 4</p>

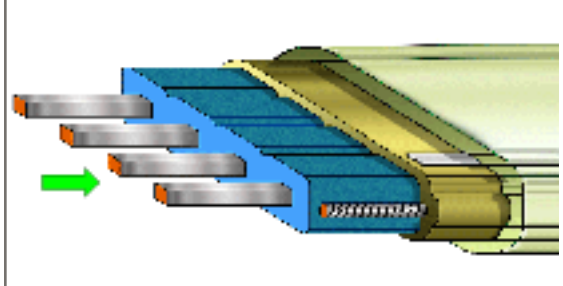
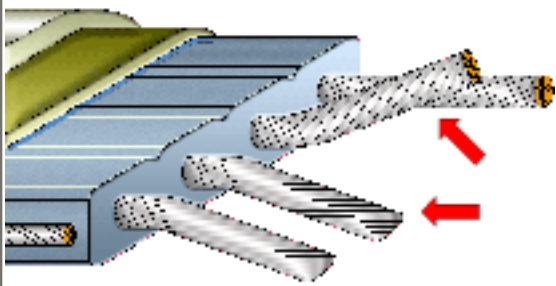
**WIRE PREPARATION
GENERAL REQUIREMENTS (cont.)**

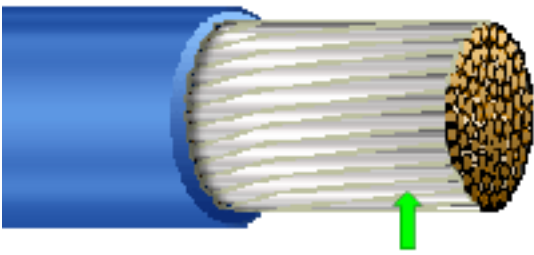
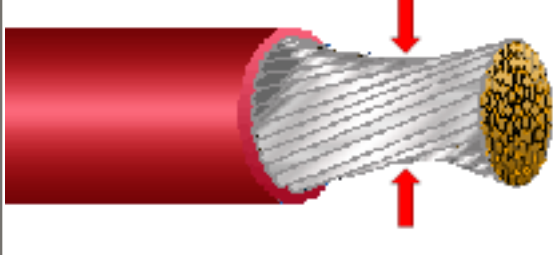

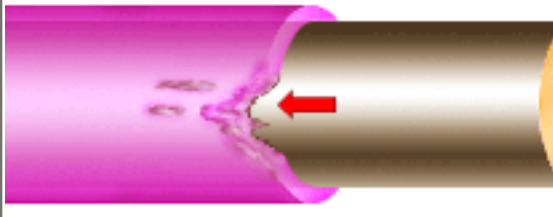
	
<p style="text-align: center;">ACCEPTABLE PLANAR ORIENTATION FLAT/RIBBON CABLE</p> <p>The individual exposed conductors should be in parallel (planar) orientation to each other, following stripping.</p> <p>Best Workmanship Practice</p>	<p style="text-align: center;">UNACCEPTABLE NON-PLANAR ORIENTATION FLAT/RIBBON CABLE</p> <p>Non-planar oriented conductors are typically the result of poor handling. The conductors may be returned to their original orientation, provided no other damage is present.</p> <p>Best Workmanship Practice</p>

	
<p style="text-align: center;">ACCEPTABLE RETWISTED LAY</p> <p>If the twist pattern (lay) of wire strands is disturbed, it shall be restored as nearly as possible to the original pattern. Retwisted lay is acceptable, provided no other damage is evident.</p> <p>NASA-STD-8739.3 [7.2.4] NASA-STD-8739.4 [10.1.4], [19.6.1.a.2]</p>	<p style="text-align: center;">UNACCEPTABLE OVERTWISTED STRANDS</p> <p>Strands twisted in excess of the normal twist pattern (lay) exert increased stress on individual strands, and may result in conductor breakage.</p> <p>NASA-STD-8739.3 [7.2.4] NASA-STD-8739.4 [10.1.4]</p>
	
<p style="text-align: center;">ACCEPTABLE SCUFFED INSULATION/JACKET</p> <p>Slight scuffing (a dull or rubbed appearance) of the insulation surface finish is acceptable, provided no other damage is evident.</p> <p>NASA-STD-8739.3 [7.2.2] NASA-STD-8739.4 [10.1.2]</p>	<p style="text-align: center;">UNACCEPTABLE DAMAGED INSULATION/JACKET</p> <p>The conductor insulation and /or cable jacket shall not exhibit any damage, such as nicks, cuts, or charring. Conductors/Jackets exhibiting damage (other than minor scuffing) shall not be used.</p> <p>NASA-STD-8739.3 [13.6.2.a.1] NASA-STD-8739.4 [19.6.2.a.2]</p>



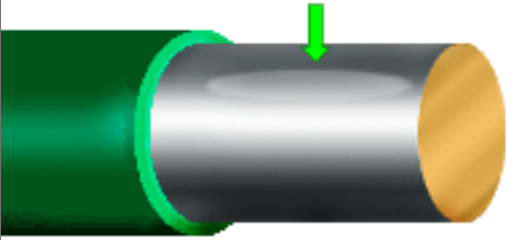
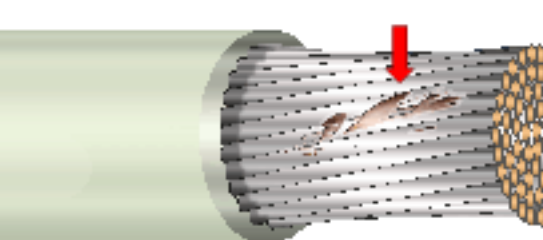

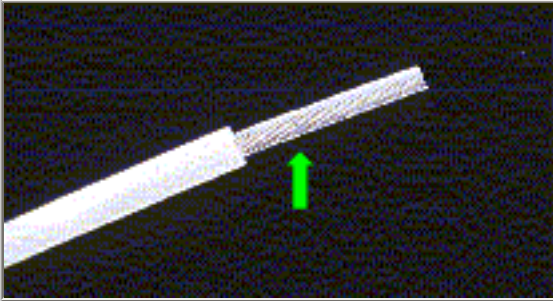
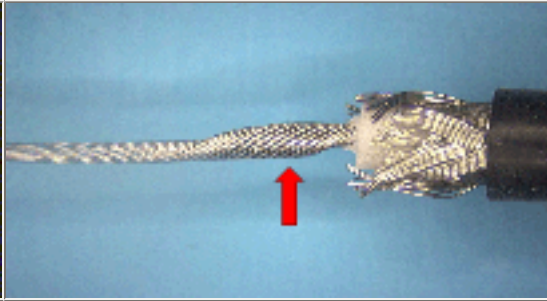
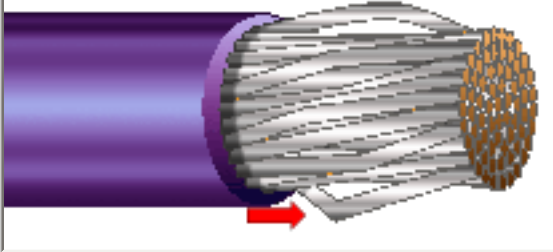
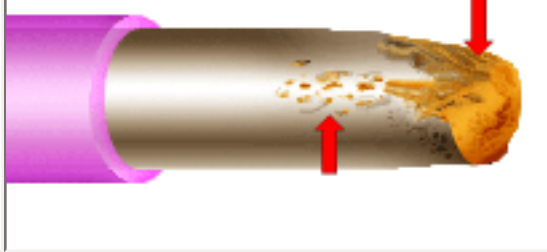
NASA WORKMANSHIP STANDARDS

 <p>NATIONAL AERONAUTICS AND SPACE ADMINISTRATION JOHNSON SPACE CENTER HOUSTON, TEXAS USA 77058</p>	Released:	Revision:	Revision Date:
	03.31.2000	B	07.03.2002
	Book:	Section:	Page:
1	1.01	5	

WIRE PREPARATION GENERAL REQUIREMENTS (cont.)	
	

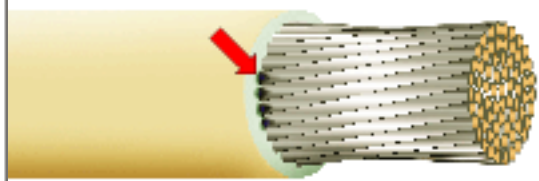
<p style="text-align: center;">ACCEPTABLE SMOOTH TOOL IMPRESSION MARKS</p> <p>Smooth tool impression marks (slight cuts, nicks, scratches or scrapes) on the conductor surface, which do not expose base metal or reduce cross-sectional area, are acceptable.</p> <p>NASA-STD-8739.3 [7.2.3] NASA-STD-8739.4 [10.1.3]</p> 	<p style="text-align: center;">UNACCEPTABLE CONDUCTOR DAMAGE</p> <p>Cuts, nicks, scratches or scrapes which reduce the conductor's overall cross-sectional area, reduce the current carrying capability and/or expose conductor base metal are rejectable.</p> <p>NASA-STD-8739.3 [7.2.3], [13.6.2.a.8] NASA-STD-8739.4 [10.1.3], [19.6.2.a.2]</p> 		
<p style="text-align: center;">ACCEPTABLE STRANDING LAY/TWIST PATTERN</p> <p>Conductor stranding exhibits a normal twist pattern (lay).</p> <p>NASA-STD-8739.3 [7.2] NASA-STD-8739.4 [10.1], [19.6.1.a]</p>	<p style="text-align: center;">UNACCEPTABLE DISTURBED LAY</p> <p>Standard conductors exhibiting a disturbed twist pattern (lay) shall be rejected. Stranding which has been returned to the original lay is acceptable, provided no other damage is present.</p> <p>NASA-STD-8739.3 [7.2.4] NASA-STD-8739.4 [10.1.4], [19.6.1.a.2]</p>		
			
<p style="text-align: center;">UNACCEPTABLE BIRDCAGED STRANDS</p> <p>Birdcaged strands are typically the result of poor handling. The strands may be returned to the original twist pattern (lay), provided no other damage is present.</p> <p>NASA-STD-8739.3 [7.2.4], [13.6.2.a.4]</p>	<p style="text-align: center;">UNACCEPTABLE BURNED/CORRODED CONDUCTOR (CHEMICAL STRIPPING)</p> <p>Burns and/or corrosion are typically caused by the use of an extremely aggressive or chemically incompatible stripping agent, or excessive exposure.</p> <p>NASA-STD-8739.3 [6.6.2.c], [13.6.2.a.7] NASA-STD-8739.4 [19.6.2.a.2]</p>		
<p>NASA WORKMANSHIP STANDARDS</p>			
 <p>NATIONAL AERONAUTICS AND SPACE ADMINISTRATION JOHNSON SPACE CENTER HOUSTON, TEXAS USA 77058</p>	<p>Released: 03.31.2000</p>	<p>Revision: B</p>	<p>Revision Date: 07.03.2002</p>
	<p>Book: 1</p>	<p>Section: 1.01</p>	<p>Page: 6</p>

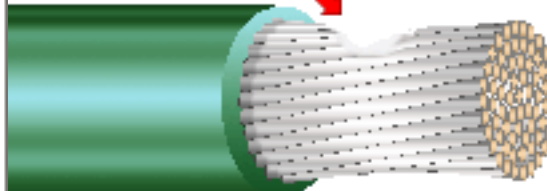
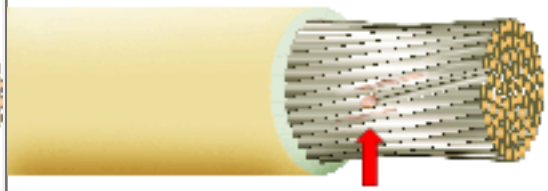
**WIRE PREPARATION
GENERAL REQUIREMENTS (cont.)**

	
<p style="text-align: center;">UNACCEPTABLE BURNED/ETCHED STRANDS (THERMAL STRIPPING)</p> <p>Burned or etched strands are typically caused by current flow between the thermal stripper blades, or as a result of stripping an energized conductor.</p> <p>NASA-STD-8739.3 [6.6.2.b], [13.6.3.a.7] NASA-STD-8739.4 [19.6.2.a.2]</p>	<p style="text-align: center;">UNACCEPTABLE CHEMICAL STRIPPING PROCESS INCORRECT CONDUCTOR TYPES</p> <p>Chemical stripping of other than solid, single-conductor wire (i.e.: coaxial cable, flat cable, multi-conductor cable, ribbon cable, shielded, stranded, etc.) is prohibited.</p>
	
<p style="text-align: center;">UNACCEPTABLE CRUSHED STRANDS</p> <p>Crushed strands are an indicator of improper tooling, resulting in reduced conductor cross-sectional area, reduced current carrying capability and reduced reliability.</p> <p>NASA-STD-8739.3 [7.2.3] NASA-STD-8739.4 [10.1.3], [19.6.2.a.2]</p>	<p style="text-align: center;">UNACCEPTABLE CUT OR FRAYED STRANDS</p> <p>Cut or frayed strands are an indicator of an improper process or tooling, resulting in reduced current carrying capability and reduced reliability.</p> <p>NASA-STD-8739.3 [7.2.3], [13.6.2.a.8] NASA-STD-8739.4 [10.1.3], [19.6.2.a.3]</p>
	
<p style="text-align: center;">UNACCEPTABLE DAMAGED SHIELD</p> <p>Cut, crushed, gouged, damaged or nicked shielding may result in reduced electrical isolation and/or short circuits.</p> <p>Best Workmanship Practice</p>	<p style="text-align: center;">UNACCEPTABLE OVERLAPPING STRANDS</p> <p>Strands, retwisted and overlapping each other, will result in increased stress and difficulty in insertion, or the forming of a mechanical wrap.</p> <p>NASA-STD-8739.3 [7.2.4] NASA-STD-8739.4 [10.1.4]</p>

NASA WORKMANSHIP STANDARDS

 <p>NATIONAL AERONAUTICS AND SPACE ADMINISTRATION JOHNSON SPACE CENTER HOUSTON, TEXAS USA 77058</p>	Released: 03.31.2000	Revision: B	Revision Date: 07.03.2002
	Book: 1	Section: 1.01	Page: 7

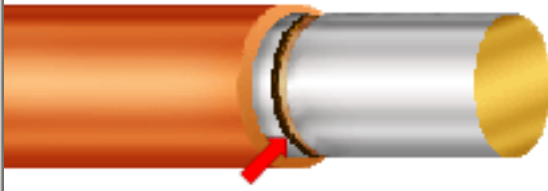
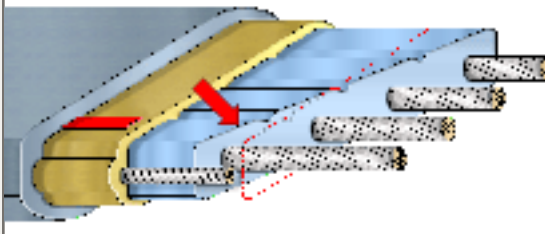
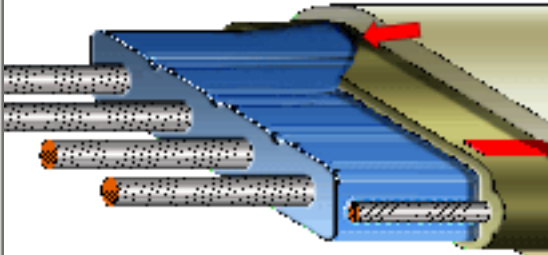
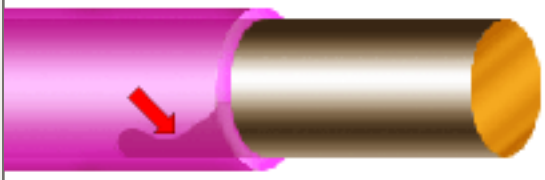
WIRE PREPARATION GENERAL REQUIREMENTS (cont.)	
	
<p style="text-align: center;">UNACCEPTABLE RINGED CONDUCTORS/STRANDS</p> <p>Ringing is a symptom of an improper process or tooling. Ringing which reduces the overall cross-sectional area and/or results in exposed base metal shall be cause for rejection.</p> <p>NASA-STD-8739.3 [6.6.1], [7.2.3], [13.6.2.a.8] NASA-STD-8739.4 [6.6.1], [10.1.3], [19.6.2.a.2]</p>	<p style="text-align: center;">UNACCEPTABLE UNEVENLY TRIMMED INSULATION</p> <p>Unevenly trimmed insulation may result in reduced electrical isolation and/or short circuits, and may interfere with terminations.</p> <p>Best Workmanship Practice</p>
	
<p style="text-align: center;">UNACCEPTABLE UNEVENLY TRIMMED SHIELD</p> <p>Unevenly trimmed shielding indicates poor technique and may result in improper electrical termination during connector assembly.</p> <p>Best Workmanship Practice</p>	<p style="text-align: center;">UNACCEPTABLE WICKING</p> <p>Wicking of chemical stripping and/or cleaning agents under the insulation jacket is a long-term reliability concern.</p> <p>NASA-STD-8739.3 [13.6.2.a.9]</p>

NASA WORKMANSHIP STANDARDS			
 <p>NATIONAL AERONAUTICS AND SPACE ADMINISTRATION JOHNSON SPACE CENTER HOUSTON, TEXAS USA 77058</p>	Released:	Revision:	Revision Date:
	03.31.2000	B	07.03.2002
	Book:	Section:	Page:
	1	1.01	8





[Need a printed copy?](#)
[\(May take a while to load.\)](#)
Requires Adobe Reader.



[Need Adobe Reader?](#)
[Click here to download.](#)

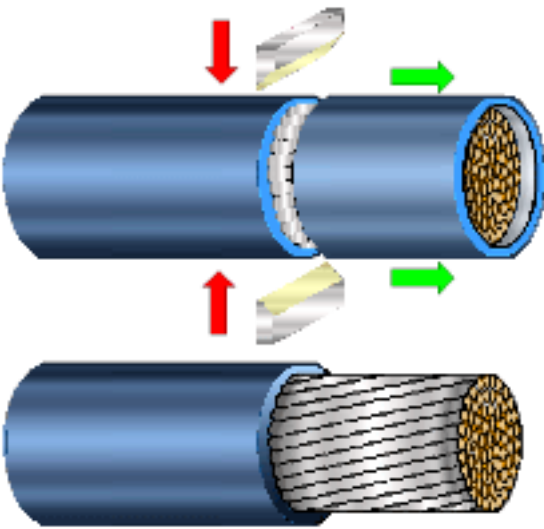
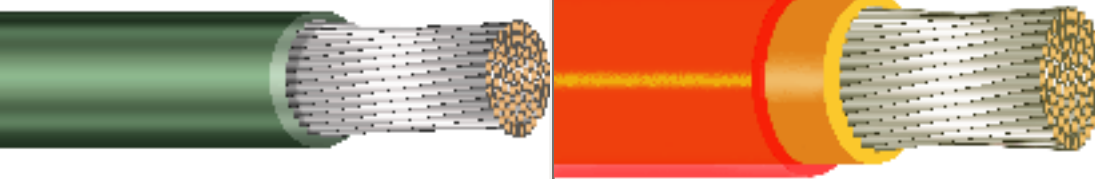
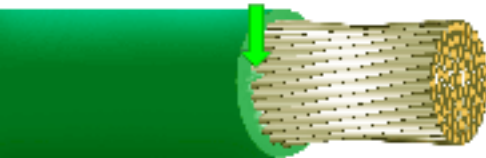
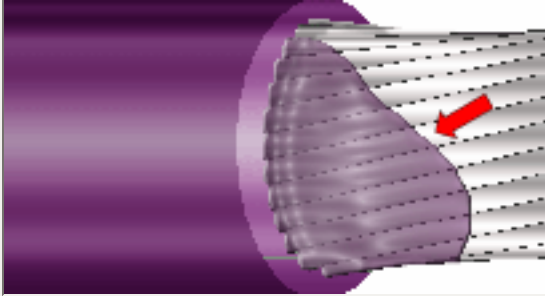

[Questions? Suggestions?](#)

WIRE PREPARATION MECHANICAL STRIPPING				
	<p style="text-align: center;"><u>MECHANICAL STRIPPING</u></p> <p>Mechanical stripping is an inexpensive, easy method of stripping most commonly used insulation materials and is the preferred method for manually stripping film insulations such as Kapton®.</p> <p>In the process, a grooved knife-edge is used to cut the insulation jacket down to the conductor. The severed insulation section is then manually removed without damaging the conductor.</p> <p>See Section 1.01 "Wire Preparation, General Requirements", for common accept/reject criteria.</p>			
				
<p>PREFERRED GENERAL REQUIREMENTS (ALL CONDUCTOR/INSULATION TYPES)</p> <p>The insulation jacket has been neatly trimmed, with no edge flash and no mechanical damage to the conductor or insulation. Conductor stranding exhibits a normal twist pattern (lay).</p>	<p>PREFERRED KAPTON® INSULATED CONDUCTORS</p> <p>The insulation jacket has been trimmed neatly and squarely, with minimal edge flash and no mechanical damage to the conductor or insulation. Conductor stranding lay (twist pattern) is undisturbed.</p>			
				
<p>ACCEPTABLE EDGE FLASH</p> <p>Edge flash shall not exceed one-quarter insulated wire diameter (1/4 d.). Edge flash is a thin layer of insulation that is produced during the stripping process, and is considered a contaminant.</p> <p>NASA-STD-8739.4 [10.1.6]</p>	<p>UNACCEPTABLE EXCESSIVE EDGE FLASH</p> <p>The edge flash is in excess of one-quarter insulated wire diameter (1/4 d.), and may interfere with the proper completion of a crimped or soldered termination.</p> <p>NASA-STD-8739.4 [10.1.6]</p>			
NASA WORKMANSHIP STANDARDS				
 <p>NATIONAL AERONAUTICS AND SPACE ADMINISTRATION JOHNSON SPACE CENTER HOUSTON, TEXAS USA 77058</p>	<table border="1" style="width: 100%;"> <tr> <td style="width: 33%;">Released: 03.31.2000</td> <td style="width: 33%;">Revision: B</td> <td style="width: 33%;">Revision Date: 07.03.2002</td> </tr> </table>	Released: 03.31.2000	Revision: B	Revision Date: 07.03.2002
Released: 03.31.2000	Revision: B	Revision Date: 07.03.2002		

	Book: 1	Section: 1.02	Page: 1
--	------------	------------------	------------

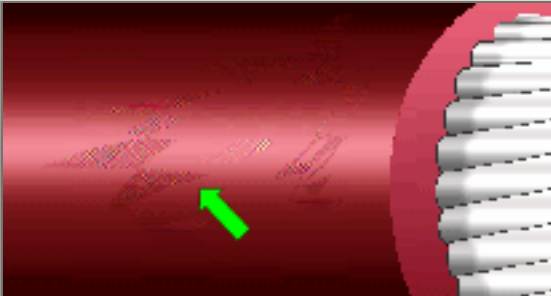
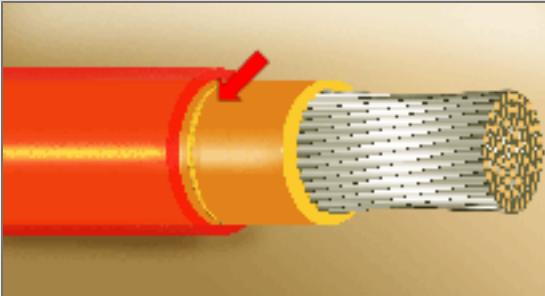
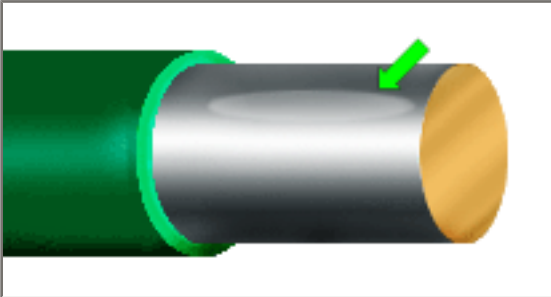
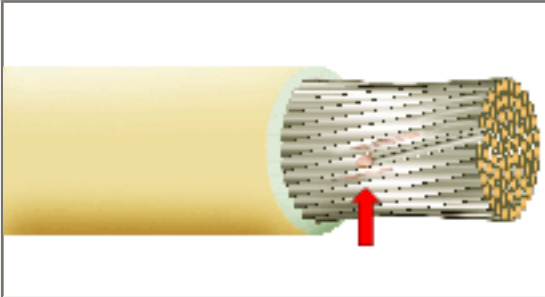
WIRE PREPARATION MECHANICAL STRIPPING (cont.)	
	
<p>ACCEPTABLE SCUFFED INSULATION/JACKET</p> <p>Slight scuffing (a dull or rubbed appearance) of the insulation surface finish is acceptable, provided no other damage is evident.</p> <p>NASA-STD-8739.3 [7.2.2] NASA-STD-8739.4 [10.1.2]</p>	<p>UNACCEPTABLE DAMAGED INSULATION/JACKET</p> <p>The conductor insulation and/or cable jacket shall not exhibit any damage, such as nicks, cuts or charring. Conductors/Jackets exhibiting damage (other than minor scuffing) shall not be used.</p> <p>NASA-STD-8739.3 [7.2.2], [13.6.2.a.1] NASA-STD-8739.4 [10.1.2], [19.6.2.a.1]</p>
	
<p>ACCEPTABLE SMOOTH TOOL IMPRESSION MARKS</p> <p>Smooth tool impression marks (slight cuts, nicks, scratches or scrapes) on the conductor surface, which do not expose base metal or reduce cross-sectional area, are acceptable.</p> <p>NASA-STD-8739.3 [7.2.3] NASA-STD-8739.4 [10.1.3]</p>	<p>UNACCEPTABLE DAMAGE TO CONDUCTORS</p> <p>Conductors that exhibit reduced cross-sectional area or exposed base metal shall be rejected.</p> <p>NASA-STD-8739.3 [7.2.3], [13.6.2.a.8] NASA-STD-8739.4 [10.1.3], [19.6.2.a.2]</p>

 NATIONAL AERONAUTICS AND SPACE ADMINISTRATION JOHNSON SPACE CENTER HOUSTON, TEXAS USA 77058	Released: 03.31.2000	Revision: B	Revision Date: 07.03.2002
	Book: 1	Section: 1.02	Page: 2



[Need a printed copy?](#)
(May take a while to load.)
Requires Adobe Reader.



[Need Adobe Reader?](#)
[Click here to download.](#)



[Questions? Suggestions?](#)

WIRE PREPARATION EXCIMER LASER ABLATIVE AND THERMAL STRIPPING	
	<p>EXCIMER LASER ABLATIVE (ELA) AND THERMAL STRIPPING</p> <p>Excimer laser ablative (ELA) stripping employs a laser to achieve extremely precise stripping of "difficult to strip" insulation materials and intricate conductor stripping geometries.</p> <p>Thermal stripping is performed using a heated tool to melt a ring or groove into the insulation down to the conductor. The severed insulation section is then manually removed without damaging the conductor.</p> <p>See Section 1.01 "Wire Preparation, General Requirements", for common accept/reject criteria.</p>
<p>PREFERRED GENERAL REQUIREMENTS</p> <p>The insulation jacket has been neatly trimmed, with no edge flash, smearing or damage. The conductor stranding lay (twist pattern) is undisturbed, and the conductor is undamaged.</p>	<p>ACCEPTABLE THERMAL DISCOLORATION</p> <p>Slight discoloration of the insulation jacket(s) at the trimmed edge is acceptable. Evidence of burning or charring is not acceptable.</p> <p>NASA-STD-8739.3 [7.2.2] NASA-STD-8739.4 [10.1.2], [19.6.1.a.1]</p>
<p>ACCEPTABLE EDGE FLASH</p> <p>Edge flash shall not exceed one-quarter insulated wire diameter (1/4 d.). Edge flash (as depicted) is considered normal, and should not contaminate or interfere with a crimped or soldered termination.</p> <p>NASA-STD-8739.4 [10.1.6]</p>	<p>UNACCEPTABLE EDGE FLASH/SMEARING</p> <p>The edge flash is in excess of one-quarter insulated wire diameter (1/4 d.), and the stripped section exhibits smearing (melted insulation/film), which is considered a contaminant.</p> <p>NASA-STD-8739.4 [10.1.6]</p>

NASA WORKMANSHIP STANDARDS





**NATIONAL AERONAUTICS AND
SPACE ADMINISTRATION**
JOHNSON SPACE CENTER
HOUSTON, TEXAS USA 77058

Released:
03.31.2000

Revision:
B

Revision Date:
07.03.2002

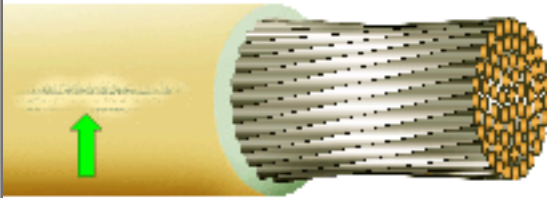
	Book: 1	Section: 1.03	Page: 1
--	------------	------------------	------------

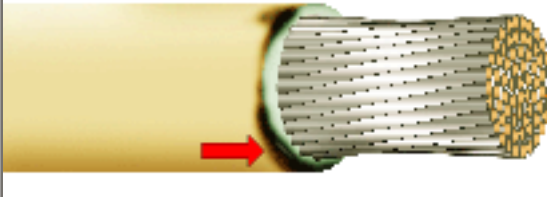
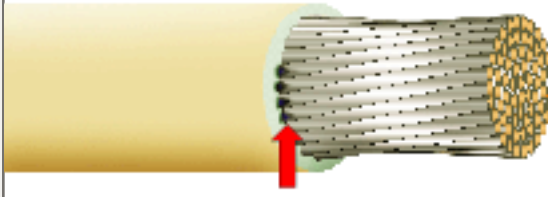
WIRE PREPARATION EXCIMER LASER ABLATIVE AND THERMAL STRIPPING (cont.)	
	
<p>ACCEPTABLE SCUFFED INSULATION/JACKET</p> <p>Slight scuffing (a dull or rubbed appearance) of the insulation surface finish is acceptable, provided no other damage is evident.</p> <p>NASA-STD-8739.3 [7.2.2] NASA-STD-8739.4 [10.1.2]</p>	<p>UNACCEPTABLE DAMAGED INSULATION/JACKET</p> <p>The conductor insulation and/or cable jacket shall not exhibit any damage, such as nicks, cuts or charring. Conductors/Jackets exhibiting damage (other than minor scuffing) shall not be used.</p> <p>NASA-STD-8739.3 [13.6.2.a.1] NASA-STD-8739.4 [19.6.2.a.2]</p>
	
<p>UNACCEPTABLE BURNED/CHARRED/PITTED INSULATION</p> <p>Burned or charred insulation is the result of excessive heat application during the stripping process.</p> <p>NASA-STD-8739.3 [6.6.1], [7.2.2], [13.6.2.a.1] NASA-STD-8739.4 [6.6.1], [10.1.2], [19.6.2.a.1]</p>	<p>UNACCEPTABLE BURNED/ETCHED STRANDS</p> <p>Burned or etched strands are typically caused by current flow (leakage) between the thermal stripper blades, or as a result of stripping an energized conductor.</p> <p>NASA-STD-8739.3 [6.6.2.b] NASA-STD-8739.4 [19.6.2.a.2]</p>

 NATIONAL AERONAUTICS AND SPACE ADMINISTRATION JOHNSON SPACE CENTER HOUSTON, TEXAS USA 77058	Released: 03.31.2000	Revision: B	Revision Date: 07.03.2002
	Book: 1	Section: 1.03	Page: 2







[Need a printed copy?](#)
(May take a while to load.)
Requires Adobe Reader.



[Need Adobe Reader?](#)
[Click here to download.](#)

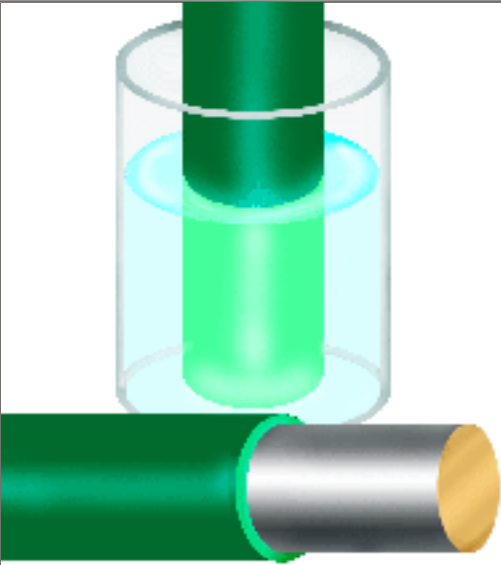

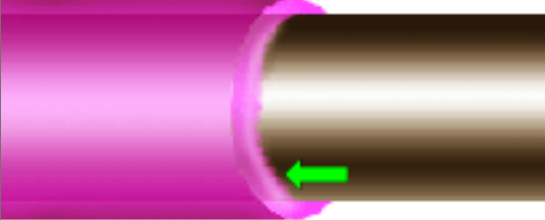
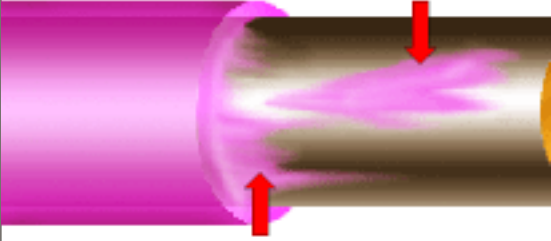
[Questions? Suggestions?](#)

WIRE PREPARATION CHEMICAL STRIPPING				
	<p style="text-align: center;"><u>CHEMICAL STRIPPING</u></p> <p>Chemical stripping of organic insulation from solid conductors is an alternative to mechanical stripping, especially on small gauge (≤ 28 ga.) conductors. The process is an efficient method to use for complete removal of the insulation, resulting in an exposed, clean, solderable conductor surface.</p> <p>Chemical stripper agents range in degrees of aggressiveness, towards both the insulation material and the conductor metallization.</p> <p>See Section 1.01 "Wire Preparation, General Requirements", for common accept/reject criteria.</p>			
				
<p>PREFERRED</p> <p>The insulation jacket has been neatly removed, with no damage to the conductor or insulation. No wicking of stripper or cleaner agents under the insulation jacket is evident.</p> <p>Note: Chemical stripping is suitable for solid conductors only.</p>	<p>UNACCEPTABLE INAPPROPRIATE CONDUCTOR TYPES</p> <p>Chemical stripping of other than solid, single-conductor wire (i.e.: coaxial cable, flat cable, multi-conductor cable, ribbon cable, shielded, stranded, etc.) is prohibited.</p> <p>Best Workmanship Practice</p>			
				
<p>ACCEPTABLE EDGE FLASH/SMEARING</p> <p>Edge flash shall not exceed one-quarter insulated wire diameter ($1/4$ d.). Edge flash and smearing (as depicted) is considered normal, and should not contaminate or interfere with crimped or soldered termination.</p> <p>NASA-STD-8739.4 [10.1.6]</p>	<p>UNACCEPTABLE EDGE FLASH/SMEARING</p> <p>The edge flash is in excess of one-quarter insulated wire diameter ($1/4$ d.), and the stripped section exhibits smearing (melted insulation/film), which is considered a contaminant.</p> <p>NASA-STD-8739.4 [10.1.6]</p>			
NASA WORKMANSHIP STANDARDS				
 <p>NATIONAL AERONAUTICS AND SPACE ADMINISTRATION JOHNSON SPACE CENTER HOUSTON, TEXAS USA 77058</p>	<table border="1"> <tr> <td>Released: 03.31.2000</td> <td>Revision: B</td> <td>Revision Date: 07.03.2002</td> </tr> </table>	Released: 03.31.2000	Revision: B	Revision Date: 07.03.2002
Released: 03.31.2000	Revision: B	Revision Date: 07.03.2002		

	Book: 1	Section: 1.04	Page: 1
--	------------	------------------	------------

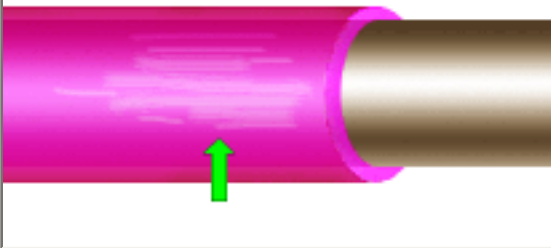
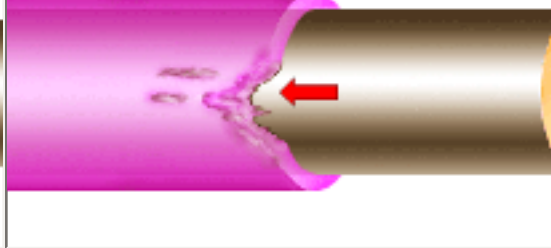
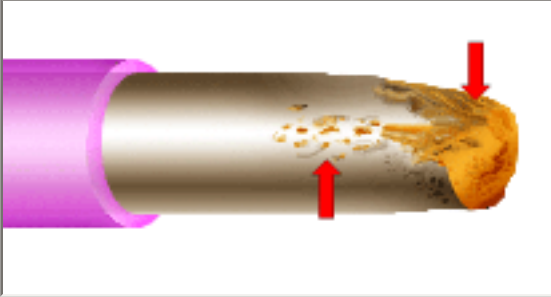
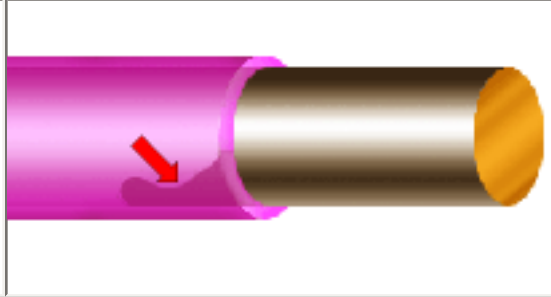
WIRE PREPARATION CHEMICAL STRIPPING (cont.)	
	
<p>ACCEPTABLE SCUFFED INSULATION/JACKET</p> <p>Slight scuffing (a dull or rubbed appearance) of the insulation surface finish is acceptable, provided no other damage is evident.</p> <p>NASA-STD-8739.3 [7.2.2] NASA-STD-8739.4 [10.1.2]</p>	<p>UNACCEPTABLE DAMAGED INSULATION/JACKET</p> <p>The conductor insulation and/or cable jacket shall not exhibit any damage, such as nicks, cuts or charring. Conductors/Jackets exhibiting damage (other than minor scuffing) shall not be used.</p> <p>NASA-STD-8739.3 [13.6.2.a.1] NASA-STD-8739.4 [19.6.2.a.2]</p>
	
<p>UNACCEPTABLE BURNS/CORROSION/PITTING</p> <p>Burns, corrosion and pitting are typically caused by the use of an extremely aggressive or chemically incompatible stripping agent, or excessive exposure.</p> <p>NASA-STD-8739.3 [13.6.2.a.7] NASA-STD-8739.4 [19.6.2.a.2]</p>	<p>UNACCEPTABLE WICKING</p> <p>Wicking of chemical stripping and/or cleaning agents under the insulation jacket is a long-term reliability concern.</p> <p>NASA-STD-8739.3 [13.6.2.a.9]</p>

 NATIONAL AERONAUTICS AND SPACE ADMINISTRATION JOHNSON SPACE CENTER HOUSTON, TEXAS USA 77058	Released: 03.31.2000	Revision: B	Revision Date: 07.03.2002
	Book: 1	Section: 1.04	Page: 2





[Need a printed copy?](#)
(May take a while to load.)
Requires Adobe Reader.



[Need Adobe Reader?](#)
[Click here to download.](#)

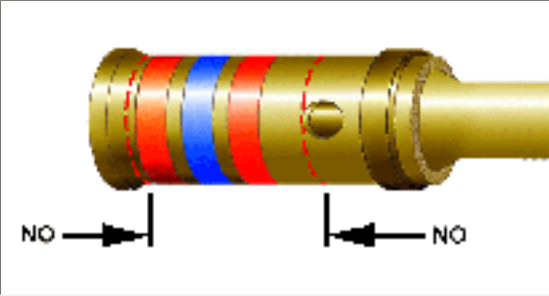
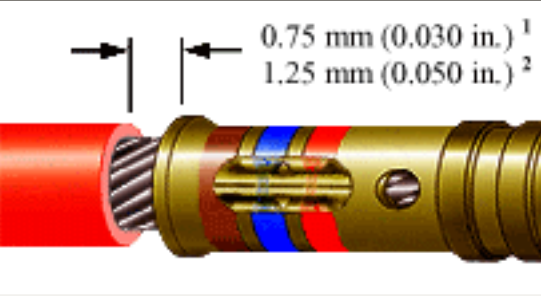
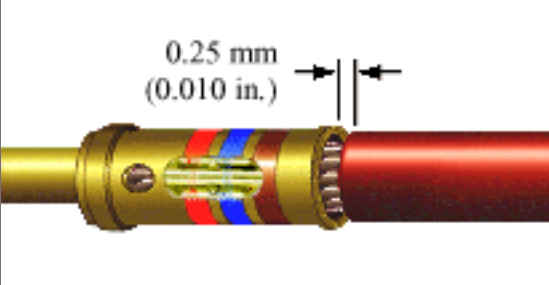

[Questions? Suggestions?](#)

CRIMPED TERMINATIONS GENERAL REQUIREMENTS	
	<p style="text-align: center;"><u>Crimped Terminations</u></p> <p>Crimping is an efficient and highly reliable method to assemble and terminate conductors, and typically provides a stronger, more reliable termination method than that achieved by soldering.</p> <p>Crimp terminations are available in different styles, depending upon the design application and connectivity requirements.</p> <p>This section details the generic accept/reject criteria of commonly used crimp termination styles. See 2.02 - 2.10 for specific accept/reject criteria applicable to individual crimp styles.</p>
	
<p>CRIMP LOCATIONS (ALL CRIMP TYPES)</p> <p>Crimp indents should be centered between the wire entry shoulder of the crimp barrel and the inspection hole/wire exit shoulder. Crimp indents shall not encroach on the wire entry shoulder or the inspection hole/wire exit shoulder.</p>	<p>MAXIMUM INSULATION CLEARANCE (ALL CRIMP TYPES)</p> <p>1. For conductors 20 AWG and smaller, the maximum clearance is 0.75 mm (0.030 in.). 2. For 18 AWG and larger conductors, the maximum clearance is 1.25 mm (0.05 in.).</p> <p>NASA-STD-8739.4 [10.1.7.b.2], [19.6.2.c.9]</p>
	
<p>MINIMUM INSULATION CLEARANCE (ALL CRIMP TYPES)</p> <p>The minimum insulation clearance for all crimped connections is 0.25 mm (0.010 in.).</p> <p>NASA-STD-8739.4 [10.1.7.b.1], [19.6.2.c.9]</p>	<p>SOLDER-TINNED STRANDED WIRE SOLID WIRE</p> <p>Crimping of solid wire, component leads, or stranded wire that has been solder-tinned, is prohibited.</p> <p>NASA-STD-8739.4 [4.3.4]</p>

NASA WORKMANSHIP STANDARDS



**NATIONAL AERONAUTICS AND
SPACE ADMINISTRATION**
JOHNSON SPACE CENTER
HOUSTON, TEXAS USA 77058

Released:
03.30.2001

Revision:

Revision Date:

	Book: 2	Section: 2.01	Page: 1
--	------------	------------------	------------

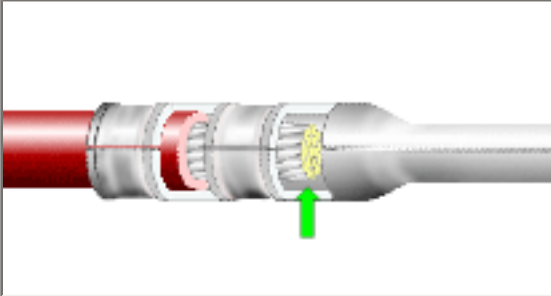
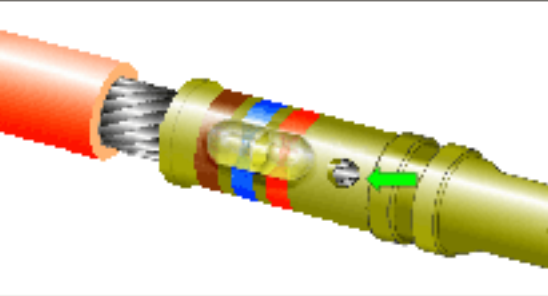
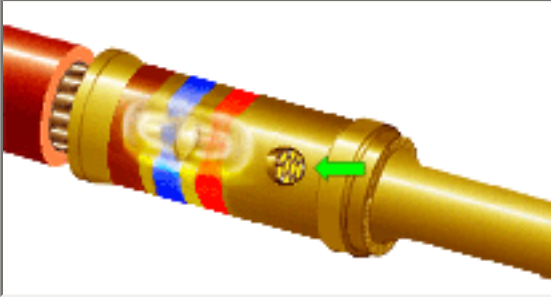
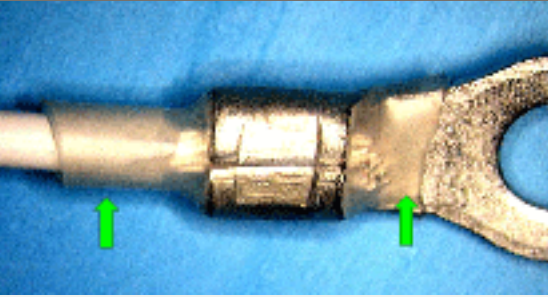
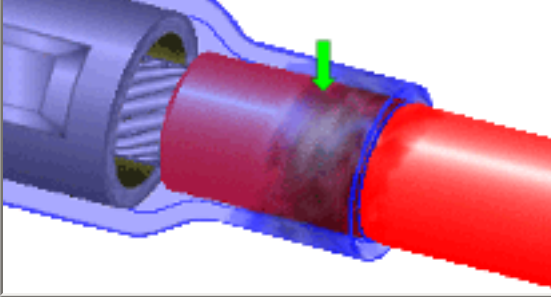
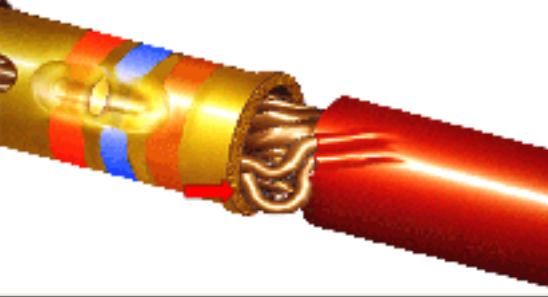
CRIMPED TERMINATIONS GENERAL REQUIREMENTS (cont.)	
	
<p>WIRE ENDS VISIBLE (LUG/OPEN BARREL CRIMPS)</p> <p>The wire ends shall be visible. The conductor should extend a minimum of even with, and a maximum of one wire diameter beyond, the conductor crimp edge.</p> <p>Best Workmanship Practice</p>	<p>WIRE STRANDS VISIBLE (PIN/CLOSED BARREL CRIMPS)</p> <p>The wire strands shall be visible in the inspection hole, indicating that the conductor is properly inserted. Preferably, the wire end should be bottomed in the crimp barrel.</p> <p>NASA-STD-8739.4 [19.6.1.c.3]</p>
	
<p>ACCEPTABLE (MINIMUM) WIRE ENDS VISIBLE (PIN/CLOSED BARREL CRIMPS)</p> <p>At a minimum, the ends of the wire strands shall be visible in the inspection hole, indicating that the conductor has been properly inserted in the crimp barrel.</p> <p>NASA-STD-8739.4 [19.6.1.c.3]</p>	<p>ACCEPTABLE HEAT SHRINK INSTALLATION</p> <p>Tubing is tight, symmetrical, undamaged (slight discoloration is acceptable). Overlaps meet minimum electrical spacing and provide strain relief. Termination is visible and inspectable.</p> <p>NASA-STD-8739.4 [9.8.1], [9.9]</p>
	
<p>ACCEPTABLE DISCOLORATION</p> <p>Slight discoloration of the shrink tubing is acceptable. Evidence of burning or charring is not acceptable.</p> <p>Best Workmanship Practice</p>	<p>UNACCEPTABLE BIRDCAGED STRANDS</p> <p>Birdcaged strands reduce the conductor's overall strength and increase the possibility of shorting.</p> <p>NASA-STD-8739.4 [19.6.2.c.3]</p>

NASA WORKMANSHIP STANDARDS			
 <p>NATIONAL AERONAUTICS AND SPACE ADMINISTRATION JOHNSON SPACE CENTER HOUSTON, TEXAS USA 77058</p>	Released: 03.30.2001	Revision:	Revision Date:
	Book: 2	Section: 2.01	Page: 2

**CRIMPED TERMINATIONS
GENERAL REQUIREMENTS (cont.)**

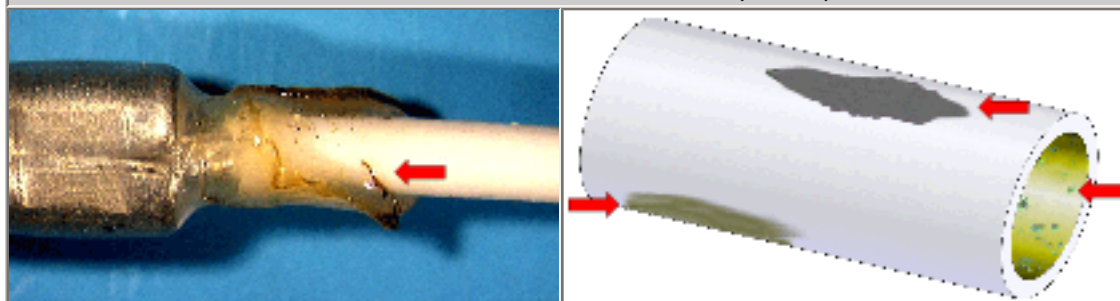

**UNACCEPTABLE
CHARRED/SPLIT HEAT SHRINK**

The heat shrink tubing has been exposed to excessive heat, resulting in charring and splitting of the sleeve and possible damage to the conductor. Slight discoloration is acceptable.
[NASA-STD-8739.4 \[9.8.1\]](#)

**UNACCEPTABLE
CONTAMINATION**

Tarnish, corrosion and/or contamination reduces the reliability of the crimp contact.
[NASA-STD-8739.4 \[12.2.2\], \[19.6.2.c.8\]](#)

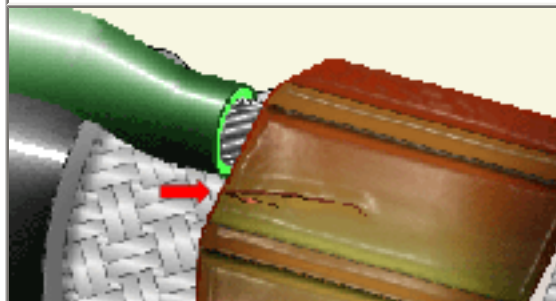

**UNACCEPTABLE
CRIMP BARREL CRACKS**

Cracks in the crimp barrel reduce the mechanical reliability of the conductor-crimp termination.
[NASA-STD-8739.4 \[19.6.2.c.2\]](#)

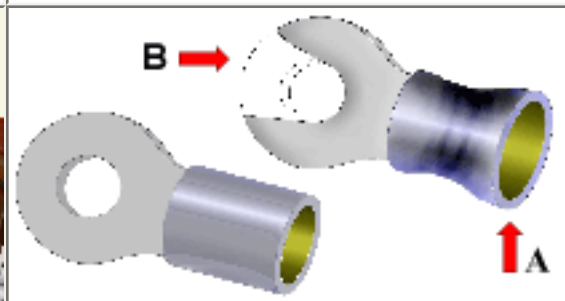

**UNACCEPTABLE
CRIMP MODIFIED TO FIT**

Modifying the crimp, to accommodate an undersized/ oversized conductor (A) or termination (B), reduces the mechanical strength and reliability of the conductor-crimp termination.
[NASA-STD-8739.4 \[4.3.5.a\], \[12.3.3\], \[19.6.2.c.6\]](#)

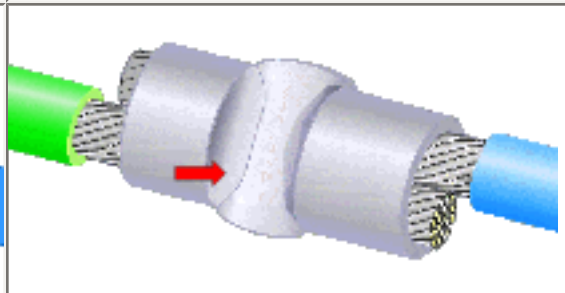
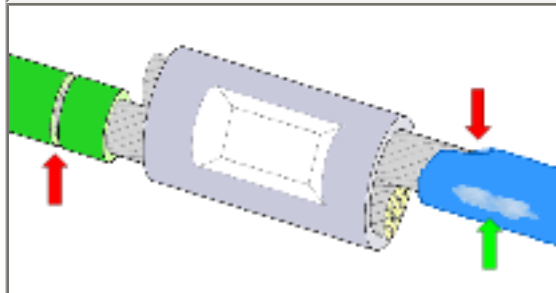

<p>UNACCEPTABLE DAMAGED INSULATION</p> <p>Cut, crushed, gouged, damaged or nicked insulation may result in reduced electrical isolation and/or short circuits. Slight scuffing or discoloration is acceptable.</p> <p>NASA-STD-8739.4 [19.6.2.a.1]</p>	<p>UNACCEPTABLE DEFORMED CRIMP</p> <p>A damaged or deformed crimp indicates the use of an incorrect crimp positioner and/or improper insertion into the crimp tool.</p> <p>NASA-STD-8739.4 [19.6.2.c.6]</p>
---	--

NASA WORKMANSHIP STANDARDS

 <p>NATIONAL AERONAUTICS AND SPACE ADMINISTRATION JOHNSON SPACE CENTER HOUSTON, TEXAS USA 77058</p>	Released: 03.30.2001	Revision:	Revision Date:
	Book: 2	Section: 2.01	Page: 3

**CRIMPED TERMINATIONS
GENERAL REQUIREMENTS (cont.)**

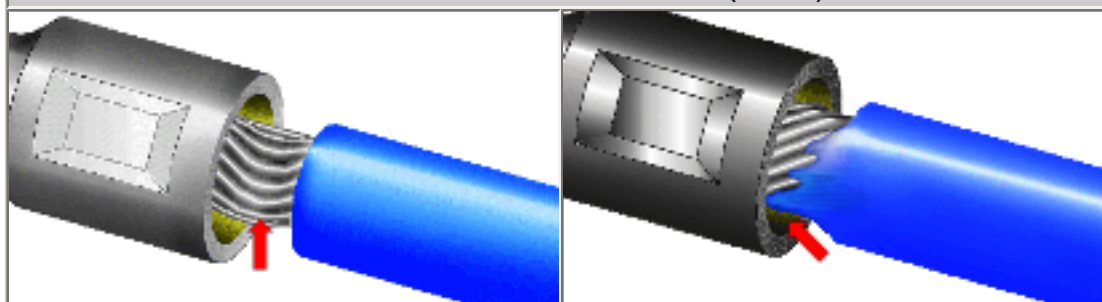

<p>UNACCEPTABLE DISTURBED LAY</p> <p>Disturbing the lay of wire strands during crimping may reduce the reliability of the crimp termination.</p> <p>Best Workmanship Practice</p>	<p>UNACCEPTABLE EDGE FLASH/INSULATION WHISKERS</p> <p>Excessive edge flash or insulation whiskers that extend into the conductor crimp section may interfere with the proper mechanical and electrical termination of the crimp.</p> <p>NASA-STD-8739.4 [19.6.2.c.10]</p>
--	--

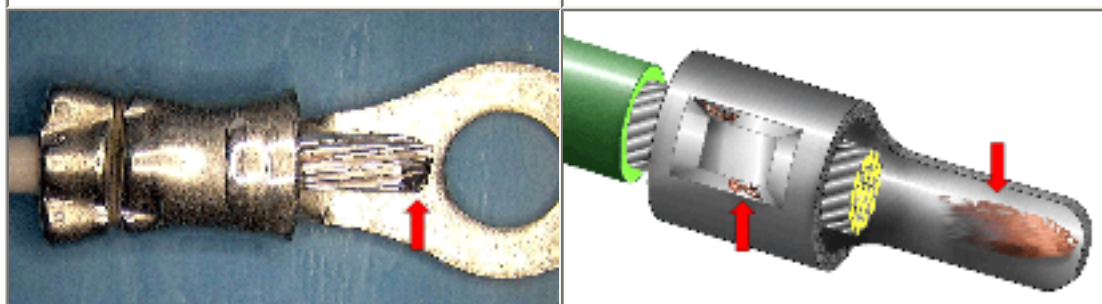

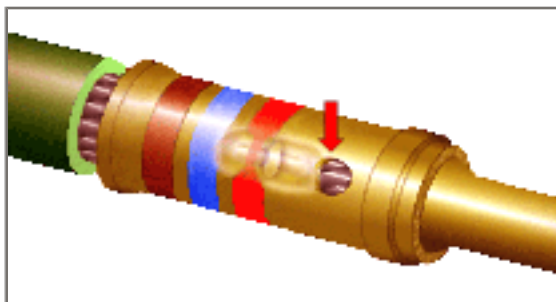
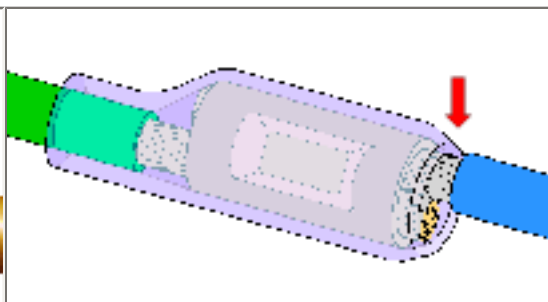

<p>UNACCEPTABLE EXCESSIVE CONDUCTOR LENGTH</p> <p>The conductor should extend a minimum of flush with, and a maximum of one (1) wire diameter beyond the conductor crimp edge.</p> <p>Best Workmanship Practice</p>	<p>UNACCEPTABLE EXPOSED BASE METAL</p> <p>Exposed base metal reduces the reliability of the crimp.</p> <p>NASA-STD-8739.4 [12.2.5], [19.6.2.c.6]</p>
--	---

	
<p style="text-align: center;">UNACCEPTABLE IMPROPER CRIMP LOCATION (INSPECTION HOLE)</p> <p>The indents shall not encroach on or distort the inspection hole.</p> <p>NASA-STD-8739.4 [19.6.2.c.7]</p>	<p style="text-align: center;">UNACCEPTABLE IMPROPER HEAT SHRINK LENGTH</p> <p>Heat shrink tubing conforms to the crimp outline, but does not extend over the wire to provide any sealing or strain relief to the conductor.</p> <p>NASA-STD-8739.4 [9.9]</p>

NASA WORKMANSHIP STANDARDS

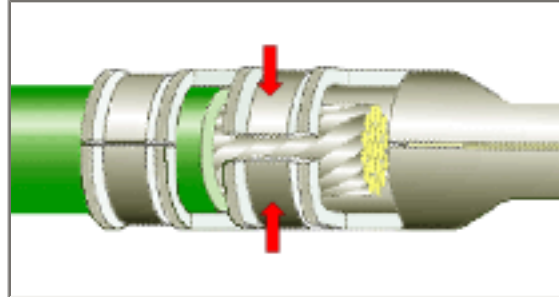
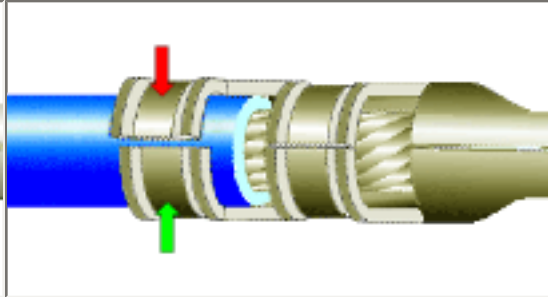
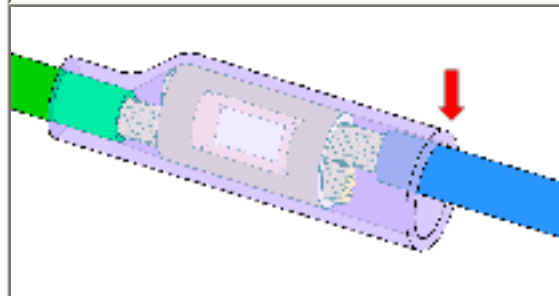
 <p>NATIONAL AERONAUTICS AND SPACE ADMINISTRATION JOHNSON SPACE CENTER HOUSTON, TEXAS USA 77058</p>	<p>Released: 03.30.2001</p>	<p>Revision:</p>	<p>Revision Date:</p>
	<p>Book: 2</p>	<p>Section: 2.01</p>	<p>Page: 4</p>

CRIMPED TERMINATIONS GENERAL REQUIREMENTS (cont.)	
	
<p style="text-align: center;">UNACCEPTABLE INCOMPLETE CONDUCTOR CRIMP</p> <p>An incomplete or improper conductor crimp will produce a conductor-crimp termination with reduced mechanical strength and reduced reliability.</p> <p>NASA-STD-8739.4 [19.6.2.c.6]</p>	<p style="text-align: center;">UNACCEPTABLE INCOMPLETE INSULATION CRIMP (MULTIPLE CRIMP PINS/SOCKETS)</p> <p>An incomplete or improperly set insulation crimp will produce a termination with reduced mechanical strength and reduced reliability.</p> <p>NASA-STD-8739.4 [19.6.2.c.6]</p>
	

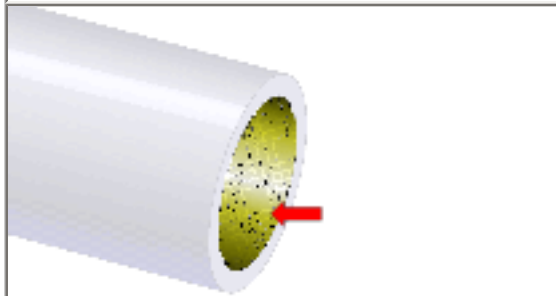
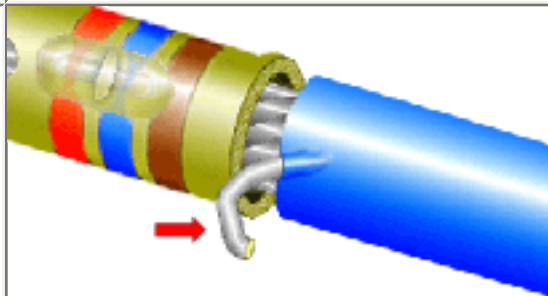
<p style="text-align: center;">UNACCEPTABLE INCOMPLETE SHRINKAGE</p> <p>The heat shrink tubing conforms to the crimp outline and extends over the wire the proper length, but does not follow the contour of the wire, or provide any sealing or strain relief.</p> <p>NASA-STD-8739.4 [9.8.1]</p>	<p style="text-align: center;">UNACCEPTABLE OPAQUE HEAT SHRINK</p> <p>Heat shrink tubing is opaque, prohibiting visual inspection of the termination. Heat shrink tubing shall be transparent or translucent, allowing visual inspection of termination.</p> <p>Best Workmanship Practice</p>
	
<p style="text-align: center;">UNACCEPTABLE PEELING/FLAKING PLATING</p> <p>A contact exhibiting peeling or flaking plating indicates a component of questionable quality and shall be rejected.</p> <p>NASA-STD-8739.4 [12.2.3], [19.6.2.c.5]</p>	<p style="text-align: center;">UNACCEPTABLE PROTRUDING STRANDS</p> <p>Protruding strands reduce the current capacity of the termination, and present a puncture, sharp object damage or shorting risk.</p> <p>Best Workmanship Practice</p>

NASA WORKMANSHIP STANDARDS

 <p>NATIONAL AERONAUTICS AND SPACE ADMINISTRATION JOHNSON SPACE CENTER HOUSTON, TEXAS USA 77058</p>	<p>Released: 03.30.2001</p>	<p>Revision:</p>	<p>Revision Date:</p>
	<p>Book: 2</p>	<p>Section: 2.01</p>	<p>Page: 5</p>

**CRIMPED TERMINATIONS
GENERAL REQUIREMENTS (cont.)**

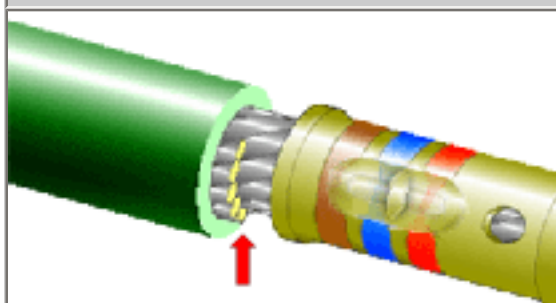
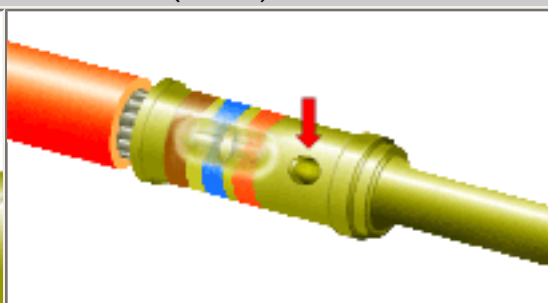
	
<p style="text-align: center;">UNACCEPTABLE WIRE MODIFIED TO FIT</p> <p>Modifying wires to fit the crimp barrel reduces the current carrying capacity and mechanical reliability of the conductor-crimp termination.</p> <p>NASA-STD-8739.4 [4.3.5.a], [12.3.3], [19.6.2.a.2]</p>	<p style="text-align: center;">UNACCEPTABLE WIRE STRANDS NOT VISIBLE (PIN/CLOSED BARREL CRIMPS)</p> <p>Wire strands not visible in the inspection hole indicate that the conductor may not be properly inserted and shall be cause for rejection.</p> <p>NASA-STD-8739.4 [19.6.2.c.4]</p>

NASA WORKMANSHIP STANDARDS			
 NATIONAL AERONAUTICS AND SPACE ADMINISTRATION JOHNSON SPACE CENTER HOUSTON, TEXAS USA 77058	Released: 03.30.2001	Revision:	Revision Date:
	Book: 2	Section: 2.01	Page: 6



[Need a printed copy?](#)
(May take a while to load.)
Requires Adobe Reader.



[Need Adobe Reader?](#)
[Click here to download.](#)



[Questions? Suggestions?](#)

CRIMPED TERMINATIONS CRIMP PINS & SOCKETS	
	<p align="center"><u>CRIMP PINS & SOCKETS</u></p> <p>The most common version of crimp terminations used in aerospace and military harness assemblies is the "pin and socket".</p> <p>See Section 2.01 "Crimped Terminations - General Requirements" for common accept/reject criteria.</p>
<p align="center">PREFERRED</p> <p>The contact has been deformed only by tool indenters. Indents symmetrically and centered between the inspection hole and the wire entry shoulder. No exposed base metal or other damage. Wire strands are visible in the inspection hole. Proper insulation spacing.</p> <p>NASA-STD-8739.4 [19.6.1.c]</p>	<p align="center">ACCEPTABLE CRIMP LOCATION - VIEW 1</p> <p>The indents are at the maximum allowable positions (adjacent to the crimp boundary), but will not encroach on or distort the wire entry shoulder of the crimp barrel and the inspection hole if the contact is rotated (see view 2).</p> <p>NASA-STD-8739.4 [19.6.1.c]</p>
<p align="center">ACCEPTABLE CRIMP LOCATION - VIEW 2</p> <p>The indent is located adjacent to the inspection hole, but does not encroach on or distort the inspection hole.</p> <p>NASA-STD-8739.4 [19.6.1.c]</p>	

NASA WORKMANSHIP STANDARDS



NATIONAL AERONAUTICS AND SPACE ADMINISTRATION
JOHNSON SPACE CENTER
HOUSTON, TEXAS USA 77058

Released:
03.30.2001

Revision:

Revision Date:

	Book: 2	Section: 2.02	Page: 1
--	------------	------------------	------------



[Need a printed copy?](#)
(May take a while to load.)
Requires Adobe Reader.



[Need Adobe Reader?](#)
[Click here to download.](#)

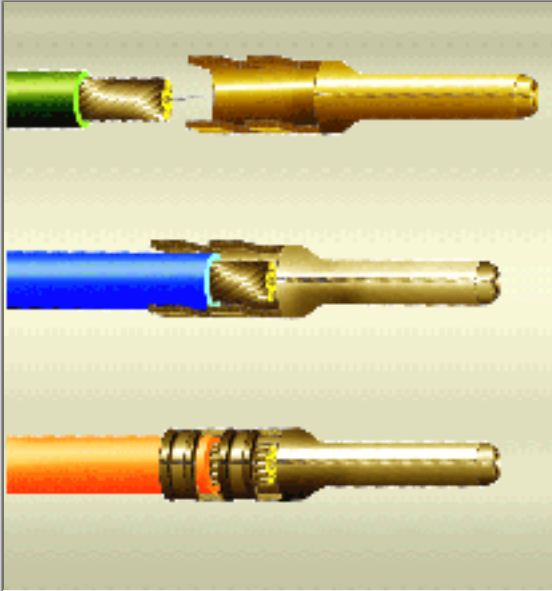
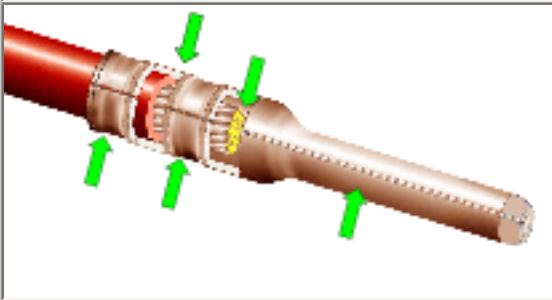
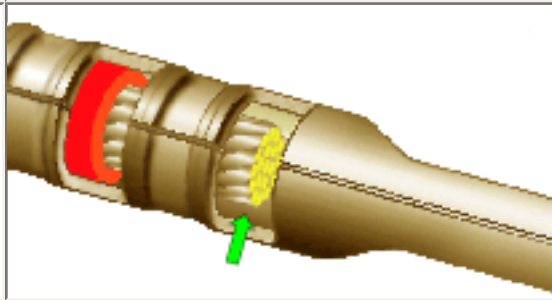
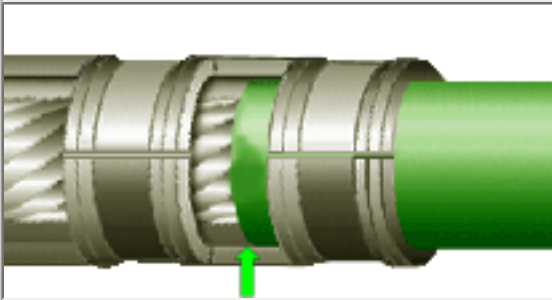
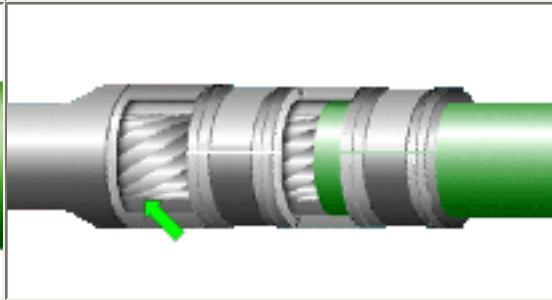

[Questions? Suggestions?](#)

CRIMPED TERMINATIONS MULTIPLE CRIMP PINS & SOCKETS	
	<p align="center"><u>MULTIPLE CRIMP PINS & SOCKETS</u></p> <p>Multiple crimp pins and sockets are characterized by the presence of separate crimp devices to secure the conductor and the insulation jacket.</p> <p>The conductor crimp grips the conductor to complete the electrical termination. The insulation crimp grips the insulation jacket to provide strain-relief to the termination.</p> <p>See Section 2.01 "Crimped Terminations - General Requirements" for common accept/reject criteria.</p>
	
<p align="center">PREFERRED</p> <p>Insulation and conductor crimps are properly set and exhibit proper insulation and conductor spacing. Wire strands visible. No exposed base metal or mechanical damage.</p>	<p align="center">PREFERRED CONDUCTOR LENGTH</p> <p>The conductor should extend a minimum of flush with and a maximum of one (1) wire diameter beyond the conductor crimp edge.</p> <p>Best Workmanship Practice</p>
	
<p align="center">PREFERRED INSULATION LENGTH</p> <p>The insulation should extend approximately midway between the insulation crimp and the conductor crimp.</p> <p>Best Workmanship Practice</p>	<p align="center">ACCEPTABLE EXCESS CONDUCTOR LENGTH</p> <p>The conductor may extend into the pin or socket barrel, provided the excess conductor length does not interfere with the mechanical and electrical mating of the pin and/or socket.</p> <p>Best Workmanship Practice</p>

NASA WORKMANSHIP STANDARDS



NATIONAL AERONAUTICS AND SPACE ADMINISTRATION
JOHNSON SPACE CENTER
HOUSTON, TEXAS USA 77058

Released:
03.30.2001

Revision:

Revision Date:

	Book: 2	Section: 2.03	Page: 1
--	------------	------------------	------------

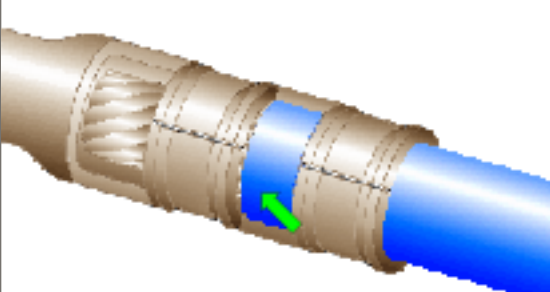
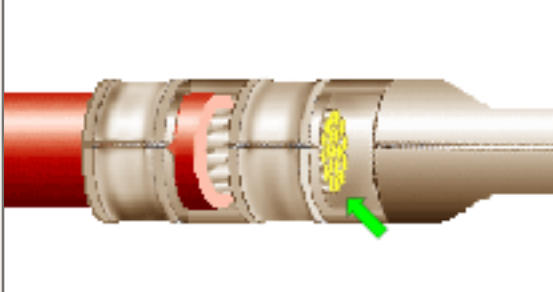
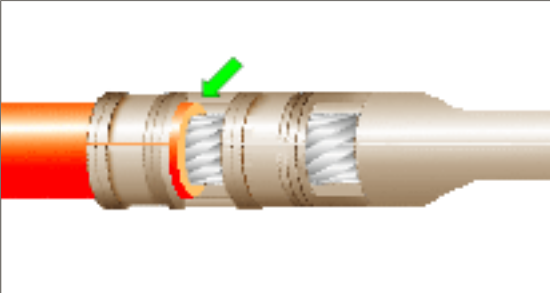
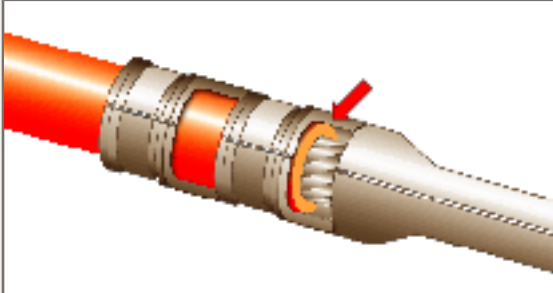
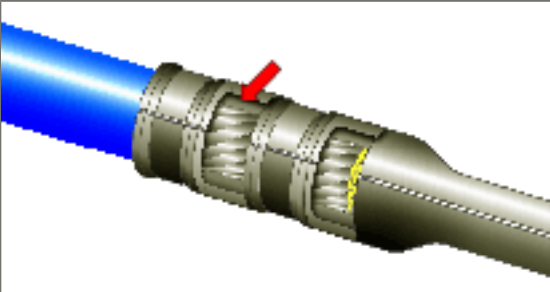
CRIMPED TERMINATIONS MULTIPLE CRIMP PINS & SOCKETS (cont.)	
	
<p>ACCEPTABLE EXCESS INSULATION LENGTH</p> <p>The insulation may extend to the leading edge of the conductor crimp, provided it can be determined visually that the insulation does not enter the conductor crimp.</p> <p>Best Workmanship Practice</p>	<p>ACCEPTABLE MINIMUM CONDUCTOR LENGTH</p> <p>The conductor should extend a minimum of flush with the conductor crimp edge.</p> <p>Best Workmanship Practice</p>
	
<p>ACCEPTABLE MINIMUM INSULATION LENGTH</p> <p>At a minimum, the insulation edge may be flush with the trailing edge of the insulation crimp.</p> <p>Best Workmanship Practice</p>	<p>UNACCEPTABLE INSULATION ENCROACHMENT</p> <p>Insulation encroachment into the conductor crimp section may interfere with the proper mechanical and electrical termination of the crimp.</p> <p>NASA-STD-8739.4 [19.6.2.c.9]</p>
	
<p>UNACCEPTABLE IMPROPER STRAIN RELIEF</p> <p>The insulation jacket must extend beyond the edge of the insulation crimp, and the crimp must fully engage the jacket to ensure proper strain-relief to the termination.</p> <p>NASA-STD-8739.4 [19.6.2.c.9]</p>	

NASA WORKMANSHIP STANDARDS			
 NATIONAL AERONAUTICS AND SPACE ADMINISTRATION JOHNSON SPACE CENTER HOUSTON, TEXAS USA 77058	Released: 03.30.2001	Revision:	Revision Date:
	Book: 2	Section: 2.03	Page: 2



[Need a printed copy?](#)
(May take a while to load.)
Requires Adobe Reader.



[Need Adobe Reader?](#)
[Click here to download.](#)

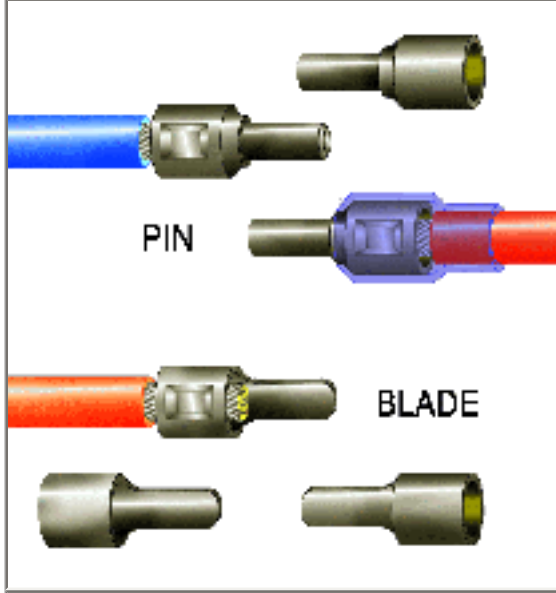
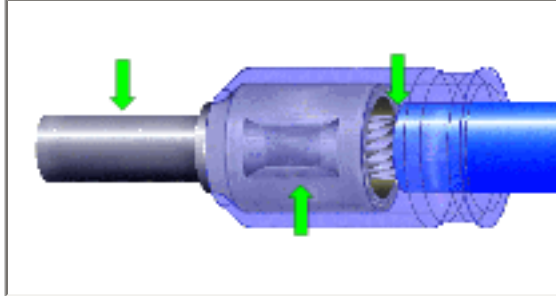
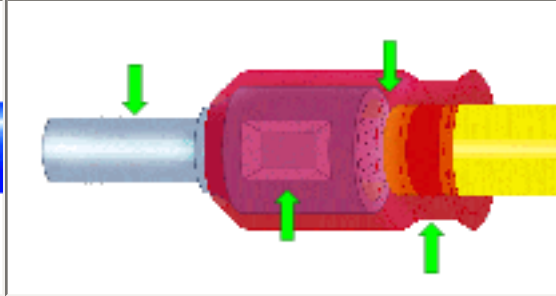
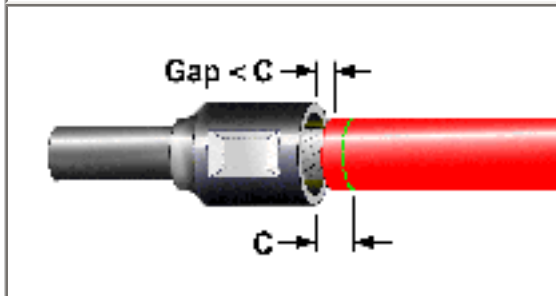

[Questions? Suggestions?](#)

CRIMPED TERMINATIONS BLADE/PIN TERMINALS	
 <p>PIN</p> <p>BLADE</p>	<p><u>BLADE / PIN TERMINALS</u></p> <p>Blade / Pin terminals are used to dress and terminate a conductor for insertion into a wire termination block (strip), providing a finished/non-fraying end to the conductor.</p> <p>See Section 2.01 "Crimped Terminations - General Requirements" for common accept/reject criteria.</p>
	
<p>PREFERRED SINGLE CRIMP INSULATED</p> <p>The contact has been deformed only by tool indenters. Indents are symmetrical and centered on the crimp barrel. No exposed base metal or other damage. Proper insulation spacing (C).</p> <p>NASA-STD-8739.4 [19.6.1.c]</p>	<p>PREFERRED DUAL CRIMP INSULATED</p> <p>The contact has been deformed only by tool indenters. Indents are symmetrical and properly located. Insulation crimp is properly set to provide appropriate strain relief. No exposed base metal. Proper insulation spacing (C).</p> <p>NASA-STD-8739.4 [19.6.1.c]</p>
	
<p>PREFERRED UNINSULATED</p> <p>The contact has been deformed only by tool indenters. Indents are symmetrical and centered on the crimp barrel. No exposed base metal or other damage. Proper insulation spacing (C).</p> <p>NASA-STD-8739.4 [19.6.1.c]</p>	

NASA WORKMANSHIP STANDARDS



**NATIONAL AERONAUTICS AND
SPACE ADMINISTRATION**
JOHNSON SPACE CENTER
HOUSTON, TEXAS USA 77058

Released:
03.30.2001

Revision:

Revision Date:

	Book: 2	Section: 2.04	Page: 1
--	------------	------------------	------------



[Need a printed copy?](#)
(May take a while to load.)
Requires Adobe Reader.



[Need Adobe Reader?](#)
[Click here to download.](#)



[Questions? Suggestions?](#)

**CRIMPED TERMINATIONS
RING LUG TERMINALS**

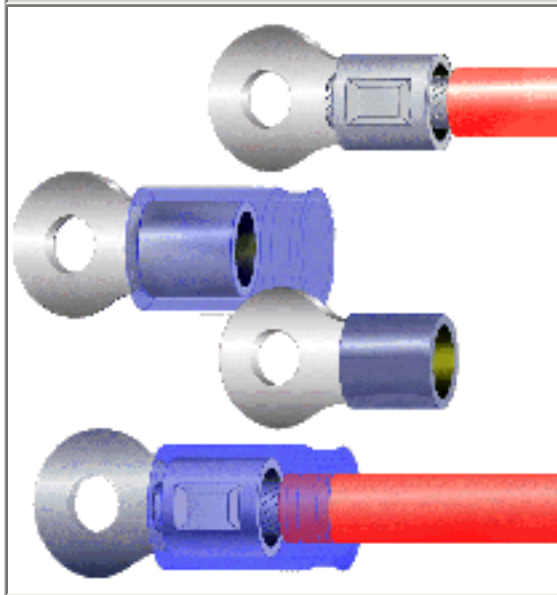

RING LUG TERMINALS

Ring lug terminals are used to dress and terminate a conductor in a configuration requiring a mechanically captured connection to a termination point or post.

The "capture" feature of a ring lug prevents the terminal from falling off the termination post, even if the compression nut has loosened. This additional security feature may be beneficial in high vibration applications.

See Section 2.01 "Crimped Terminations - General Requirements" for common accept/reject criteria.

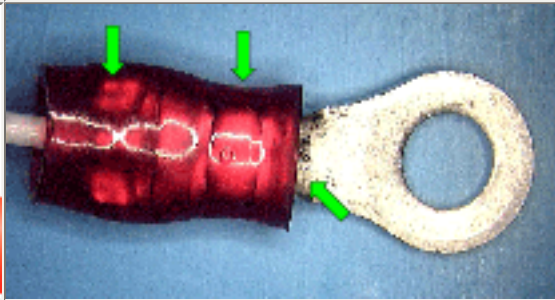
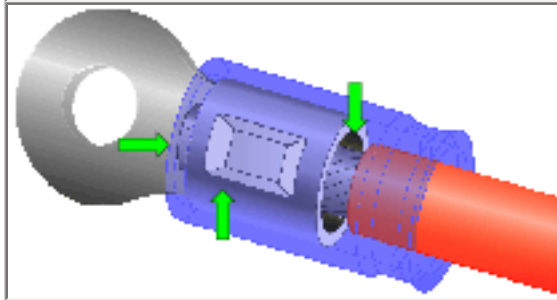

**PREFERRED
SINGLE CRIMP INSULATED**

The contact has been deformed only by tool indenters. Indents are symmetrical and centered on the crimp barrel. No exposed base metal or other damage. Wire strand ends are visible. Proper insulation spacing (C).

[NASA-STD-8739.4 \[19.6.1.c\]](#)

**PREFERRED
DUAL CRIMP INSULATED**

The contact has been deformed only by tool indenters. Indents are symmetrical and properly located. Insulation crimp is properly set to provide appropriate strain relief. Wire strand ends are visible. Proper insulation spacing (C).

[NASA-STD-8739.4 \[19.6.1.c\]](#)

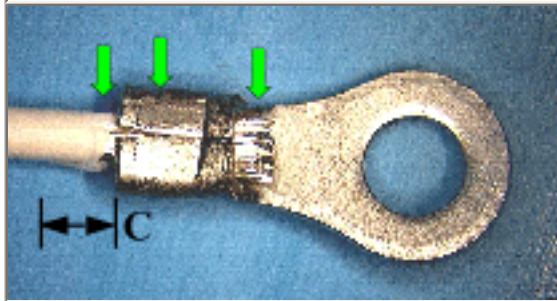

**PREFERRED
UNINSULATED**

The contact has been deformed only by tool indenters. Indents are symmetrical and centered on the crimp barrel. No exposed base metal or other damage. Wire strand ends are visible. Proper insulation spacing.

[NASA-STD-8739.4 \[19.6.1.c\]](#)

NASA WORKMANSHIP STANDARDS

	Released: 03.30.2001	Revision:	Revision Date:
--	-------------------------	-----------	----------------

	NATIONAL AERONAUTICS AND SPACE ADMINISTRATION JOHNSON SPACE CENTER HOUSTON, TEXAS USA 77058	Book: 2	Section: 2.05	Page: 1
--	--	------------	------------------	------------



[Need a printed copy?](#)
(May take a while to load.)
Requires Adobe Reader.



[Need Adobe Reader?](#)
[Click here to download.](#)



[Questions? Suggestions?](#)

CRIMPED TERMINATIONS
SPADE LUG TERMINALS

SPADE LUG TERMINALS

Spade lug terminals are used to dress and terminate a conductor to a termination point or post with a mechanically secure, "partially captured" connection. The "partially captured" feature allows the terminal to be removed from a termination post without completely removing the compression nut (as is required with ring lugs). This security feature may be beneficial in moderate vibration environments where there is a requirement for the termination to be disconnected.

See Section 2.01 "Crimped Terminations - General Requirements" for common accept/reject criteria.

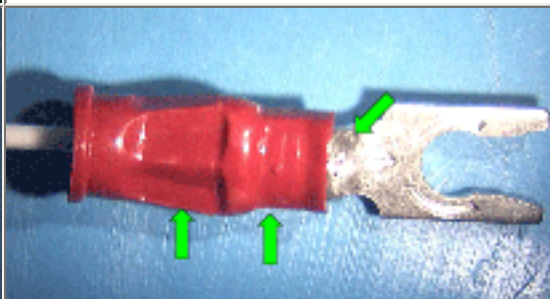
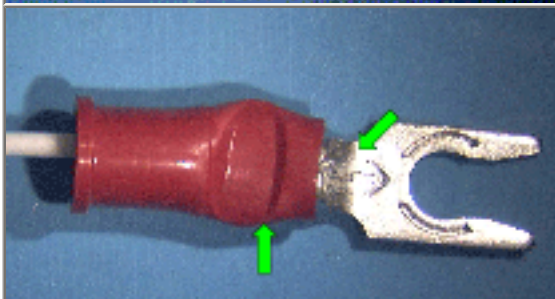
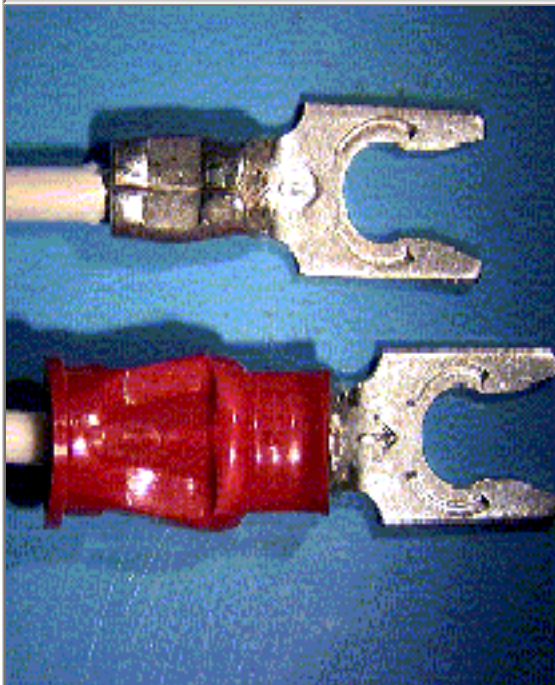

PREFERRED
SINGLE CRIMP INSULATED

The contact has been deformed only by tool indenters. Indents are symmetrical and centered on the crimp barrel. No exposed base metal or other damage. Wire strand ends are visible. Proper insulation spacing (C).

[NASA-STD-8739.4 \[19.6.1.c\]](#)

PREFERRED
DUAL CRIMP INSULATED

The contact has been deformed only by tool indenters. Indents are symmetrical and properly located. Insulation crimp is properly set to provide appropriate strain relief. Wire strand ends are visible. Proper insulation spacing (C).

[NASA-STD-8739.4 \[19.6.1.c\]](#)

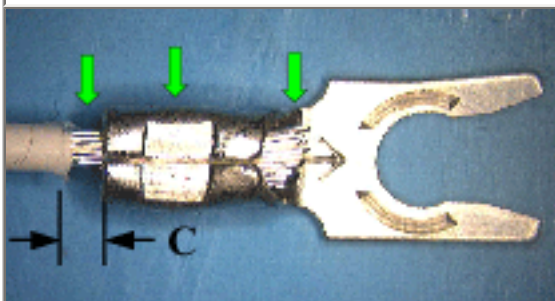

PREFERRED
UNINSULATED

The contact has been deformed only by tool indenters. Indents are symmetrical and centered on the crimp barrel. No exposed base metal or other damage. Wire strand ends are visible. Proper insulation spacing (C).

[NASA-STD-8739.4 \[19.6.1.c\]](#)

NASA WORKMANSHIP STANDARDS

 NATIONAL AERONAUTICS AND SPACE ADMINISTRATION JOHNSON SPACE CENTER HOUSTON, TEXAS USA 77058	Released: 03.30.2001	Revision:	Revision Date:
	Book: 2	Section: 2.06	Page: 1



[Need a printed copy?](#)
(May take a while to load.)
Requires Adobe Reader.



[Need Adobe Reader?](#)
[Click here to download.](#)



[Questions? Suggestions?](#)

CRIMPED TERMINATIONS
BUTT SPLICES

BUTT SPLICES

Butt splices are used to dress and terminate multiple conductors of the same or different gauges in an end-to-end or series configuration. See Section 2.01 "Crimped Terminations - General Requirements" for common accept/reject criteria.

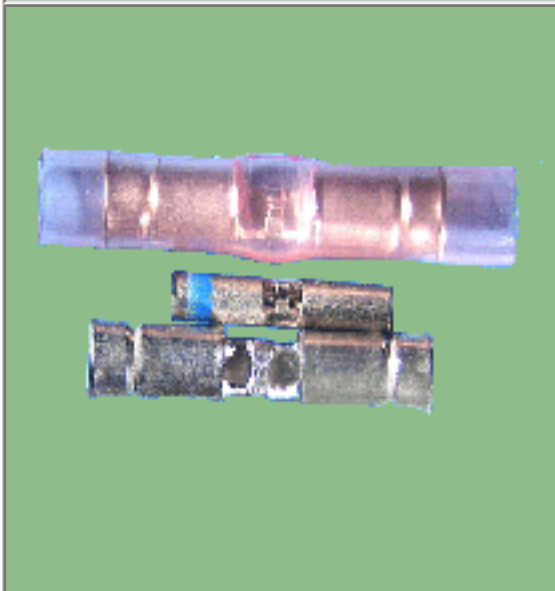

PREFERRED
SINGLE CRIMP INSULATED

The contact has been deformed only by tool indenters. Indents are symmetrical and centered on the crimp barrel. No exposed base metal or other damage. Wire strand ends are visible. Proper insulation spacing (C).

[NASA-STD-8739.4 \[19.6.1.c\]](#)

PREFERRED
DUAL CRIMP INSULATED

The contact has been deformed only by tool indenters. Indents are symmetrical and properly located. Insulation crimp is properly set, providing appropriate strain relief. Wire strand ends are visible. Proper insulation spacing (C).

[NASA-STD-8739.4 \[19.6.1.c\]](#)

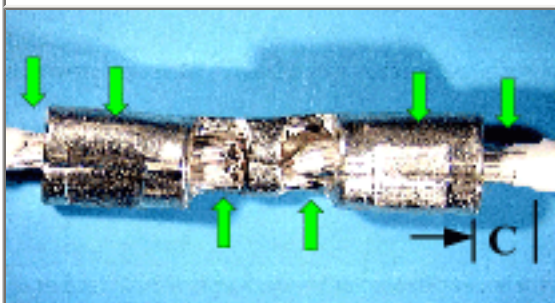

PREFERRED
UNINSULATED

The contact has been deformed only by tool indenters. Indents are symmetrical and centered on the crimp barrel. No exposed base metal or other damage. Wire strand ends are visible. Proper insulation spacing (C).

[NASA-STD-8739.4 \[19.6.1.c\]](#)

NASA WORKMANSHIP STANDARDS

Released:
03.30.2001

Revision:

Revision Date:

	NATIONAL AERONAUTICS AND SPACE ADMINISTRATION JOHNSON SPACE CENTER HOUSTON, TEXAS USA 77058	Book: 2	Section: 2.07	Page: 1
--	--	------------	------------------	------------



[Need a printed copy?](#)
(May take a while to load.)
Requires Adobe Reader.



[Need Adobe Reader?](#)
[Click here to download.](#)

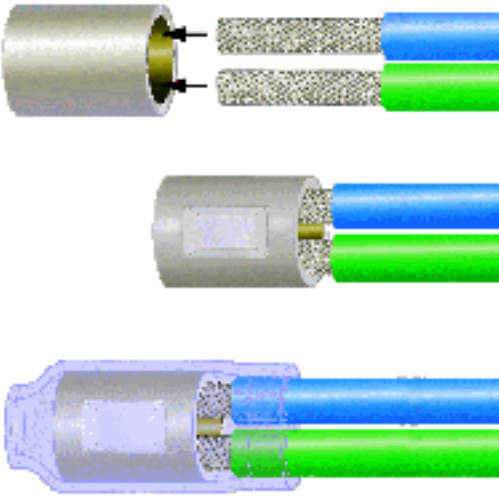
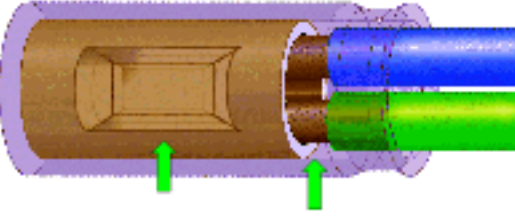
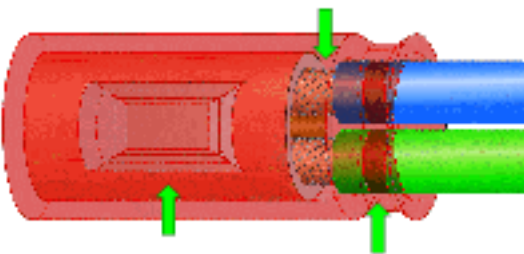
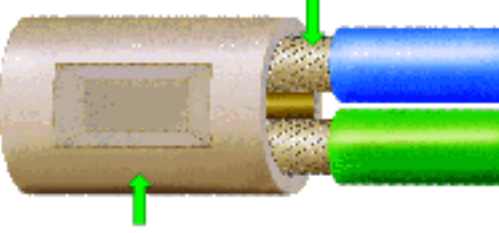
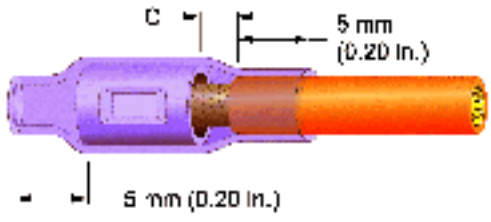

[Questions? Suggestions?](#)

CRIMPED TERMINATIONS END SPLICES		
		<p><u>END SPLICES</u></p> <p>End splices are used to terminate two or more conductors in a "pig-tail" configuration, and to "dead-end" a single conductor. They can be used as inline splices if proper strain relief is provided.</p> <p>See Section 2.01 "Crimped Terminations - General Requirements" for common accept/reject criteria.</p>
		
<p>PREFERRED SINGLE CRIMP INSULATED</p> <p>The contact has been deformed only by tool indenters. Indents are symmetrical and centered on the crimp barrel. No exposed base metal or other damage. Proper insulation spacing (C).</p> <p>NASA-STD-8739.4 [19.6.1.c]</p>	<p>PREFERRED DUAL CRIMP INSULATED</p> <p>The contact has been deformed only by tool indenters. Indents are symmetrical and properly located. Insulation crimp is properly set to provide appropriate strain relief. No exposed base metal. Proper insulation spacing (C).</p> <p>NASA-STD-8739.4 [19.6.1.c]</p>	
		
<p>PREFERRED UNINSULATED</p> <p>The contact has been deformed only by tool indenters. Indents are symmetrical and centered on the crimp barrel. No exposed base metal or other damage. Proper insulation spacing (C).</p> <p>NASA-STD-8739.4 [19.6.1.c]</p>	<p>ACCEPTABLE DEAD-END CONFIGURATION</p> <p>The contact has been deformed only by tool indenters. Indents are symmetrical and centered on the crimp barrel. No exposed base metal or other damage. Proper insulation spacing (C). Shrink tubing has been properly installed.</p> <p>NASA-STD-8739.4 [19.6.1.c]</p>	
NASA WORKMANSHIP STANDARDS		
	Released: 03.30.2001	Revision:
		Revision Date:

 NATIONAL AERONAUTICS AND SPACE ADMINISTRATION JOHNSON SPACE CENTER HOUSTON, TEXAS USA 77058	Book:	Section:	Page:
	2	2.08	1

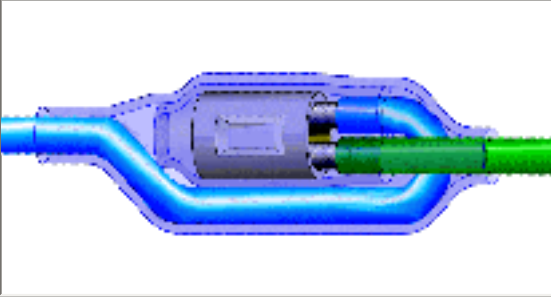
CRIMPED TERMINATIONS END SPLICES (cont.)	
	
ACCEPTABLE INLINE CONFIGURATION	
Tubing is tight and symmetrical. Overlaps meet minimum electrical spacing, while providing strain relief. The termination is visible. Conductor(s) exhibit proper bend radius and strain relief.	
NASA-STD-8739.4 [19.6.1.c]	

NASA WORKMANSHIP STANDARDS			
 NATIONAL AERONAUTICS AND SPACE ADMINISTRATION JOHNSON SPACE CENTER HOUSTON, TEXAS USA 77058	Released:	Revision:	Revision Date:
	03.30.2001		
	Book:	Section:	Page:
	2	2.08	2

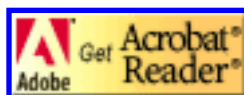

[Need a printed copy?](#)
[\(May take a while to load.\)](#)
Requires Adobe Reader.

[Need Adobe Reader?](#)
[Click here to download.](#)

[Questions? Suggestions?](#)

**CRIMPED TERMINATIONS
PARALLEL SPLICES**

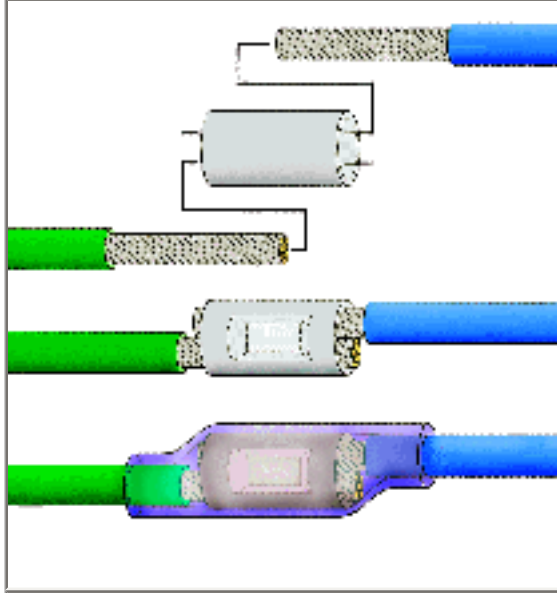

PARALLEL SPLICES

Parallel splices are used to dress and terminate multiple conductors, of the same or different gauges, in a parallel configuration.

See Section 2.01 "Crimped Terminations - General Requirements" for common accept/reject criteria.

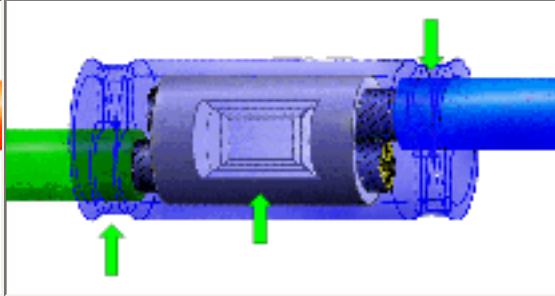
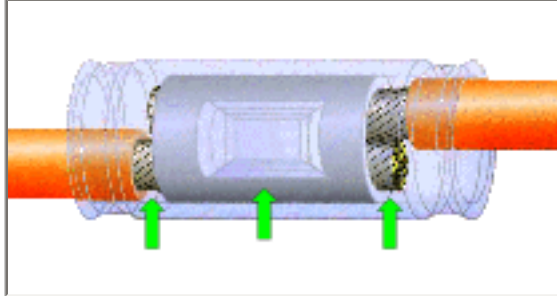

**PREFERRED
SINGLE CRIMP INSULATED**

The contact has been deformed only by tool indenters. Indents are symmetrical and centered on the crimp barrel. No exposed base metal or other damage. Wire strand ends are visible. Proper insulation spacing (C).
[NASA-STD-8739.4 \[19.6.1.c\]](#)

**PREFERRED
DUAL CRIMP INSULATED**

The contact has been deformed only by tool indenters. Indents are symmetrical and properly located. Insulation crimps are properly set to provide appropriate strain relief. No exposed base metal. Proper insulation spacing (C).
[NASA-STD-8739.4 \[19.6.1.c\]](#)

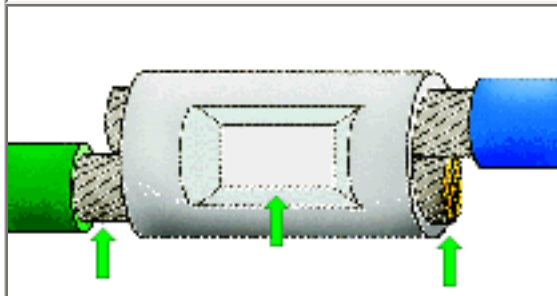

**PREFERRED
UNINSULATED**

The contact has been deformed only by tool indenters. Indents are symmetrical and centered on the crimp barrel. No exposed base metal or other damage. Wire strand ends are visible. Proper insulation spacing (C).
[NASA-STD-8739.4 \[19.6.1.c\]](#)

NASA WORKMANSHIP STANDARDS

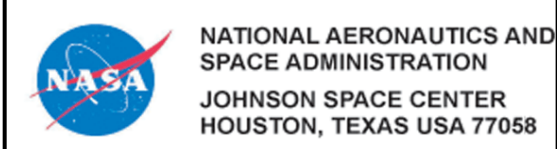

Released: 03.30.2001	Revision:	Revision Date:
-------------------------	-----------	----------------

	Book: 2	Section: 2.09	Page: 1
--	------------	------------------	------------



[Need a printed copy?](#)
(May take a while to load.)
Requires Adobe Reader.



[Need Adobe Reader?](#)
[Click here to download.](#)



[Questions? Suggestions?](#)

CRIMPED TERMINATIONS SHIELD CRIMPS	
	<p style="text-align: center;"><u>SHIELD CRIMPS</u></p> <p>Shield crimps are used to mechanically "finish" the end of individually shielded cables.</p> <p>For ground shield terminations, the crimp assembly will have a grounding wire attachment, allowing the cable shield to be electrically terminated to ground.</p> <p>For floating shield terminations, the crimp assembly will be completed without the ground wire attachment.</p> <p>See Section 2.01 "Crimped Terminations - General Requirements" for common accept/reject criteria.</p>
<p style="text-align: center;">ACCEPTABLE INTERIM ASSEMBLY VIEW</p> <p>Outer crimp ring has been deformed only by tool indenters, with indents properly located and symmetrical. Inner crimp ring has not been deformed. No exposed base metal. Ground wire has proper insulation spacing and end is visible.</p> <p>NASA-STD-8739.4 [11.5]</p>	<p style="text-align: center;">ACCEPTABLE GROUND SHIELD TERMINATION</p> <p>Heat shrink sections are properly installed, tightly shrunk, and the termination is visible. Overlaps meet minimum electrical spacing. Ground wire exhibits proper bend radius and strain relief.</p> <p>NASA-STD-8739.4 [7.3.22], [9.8.1], [9.9], [11.5], [19.6.1]</p>
<p style="text-align: center;">ACCEPTABLE FLOATING SHIELD TERMINATION</p> <p>Heat shrink tubing is properly installed, tightly shrunk, and the termination is visible. Overlaps are of sufficient length to meet minimum electrical spacing.</p> <p>NASA-STD-8739.4 [9.8.1], [9.9], [11.5], [19.6.1]</p>	<p style="text-align: center;">MANDATORY GROUND WIRE OVERHANG</p> <p>The end of the ground wire shall be flush with the outer ferrule edge, but shall not overhang the inner ferrule edge.</p> <p>NASA-STD-8739.4 [11.5]</p>

NASA WORKMANSHIP STANDARDS

Released:
03.30.2001

Revision:

Revision Date:



CRIMPED TERMINATIONS SHIELD CRIMPS (cont.)	
<p>PREFERRED GROUND WIRE ORIENTATION</p> <p>The ground wire should be dressed to the rear of the crimp termination, to allow the inclusion of a stress relief loop in the completed assembly. The ground wire may also dress forward, provided sufficient stress relief is provided.</p> <p>NASA-STD-8739.4 [11.5]</p>	<p>ACCEPTABLE GROUND WIRE INSULATION GAP</p> <p>The ground wire insulation gap shall be $\leq 0.76 \text{ mm (0.030 in.)}$. The minimum gap shall be flush with the edge of the outer crimp ring.</p> <p>NASA-STD-8739.4 [11.5]</p>
<p>ACCEPTABLE INNER/OUTER FERRULE SPACING</p> <p>The inner ferrule may extend a minimum of flush with, and a maximum of 1.7 mm (0.07 in.) beyond the front edge of the outer ferrule.</p> <p>NASA-STD-8739.4 [11.5]</p>	<p>ACCEPTABLE MIN./MAX. SHIELD/BRAID GAP</p> <p>Min.: The placement of the crimp rings shall be such that the dress of the shield stranding is not subjected to flexure stress or tensile load.</p> <p>Max.: The maximum shield gap shall not exceed 0.76 mm (0.030 in.).</p> <p>NASA-STD-8739.4 [11.5]</p>

<p style="text-align: center;">ACCEPTABLE NICKED SHIELD STRANDS</p> <p>Nicked shield strands shall not exceed 10% of the total number of strands.</p> <p>NASA-STD-8739.4 [19.6.2.b.2]</p>	<p style="text-align: center;">UNACCEPTABLE EXCESSIVE GROUND CONDUCTOR LENGTH</p> <p>The ground wire end shall be flush with the outer ferrule edge, but shall not overhang the inner ferrule.</p> <p>NASA-STD-8739.4 [11.5]</p>
--	---

NASA WORKMANSHIP STANDARDS

 <p>NATIONAL AERONAUTICS AND SPACE ADMINISTRATION JOHNSON SPACE CENTER HOUSTON, TEXAS USA 77058</p>	Released: 03.30.2001	Revision:	Revision Date:
	Book: 2	Section: 2.10	Page: 2

**CRIMPED TERMINATIONS
SHIELD CRIMPS (cont.)**

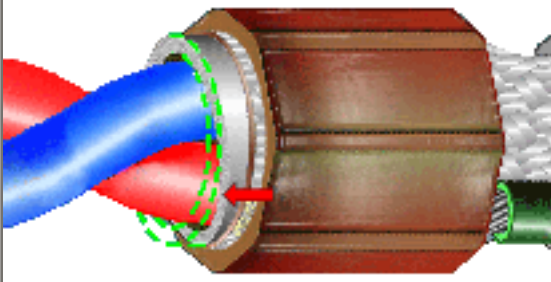
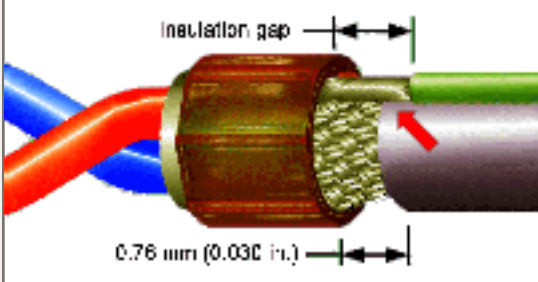
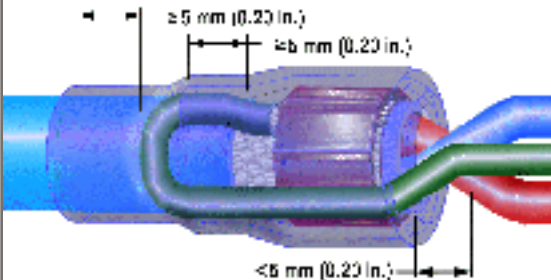
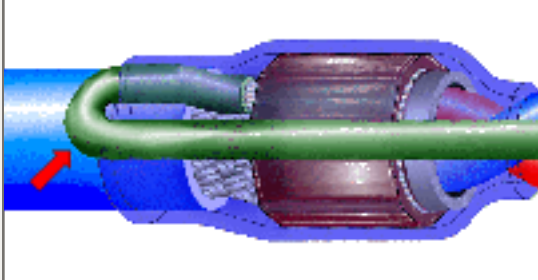
	 <p style="text-align: center;">insulation gap</p> <p style="text-align: center;">0.76 mm (0.030 in.)</p>
<p style="text-align: center;">UNACCEPTABLE IMPROPER ALIGNMENT</p> <p>Improper alignment of the ferrules reduces the reliability of the termination and indicates the use of an incorrect crimp positioner and/or improper insertion into the crimp tool.</p> <p>NASA-STD-8739.4 [19.6.2.b.4]</p>	<p style="text-align: center;">UNACCEPTABLE IMPROPER GROUND WIRE INSULATION GAP</p> <p>The ground wire insulation gap shall be ≤ 0.76 mm (0.030 in.). The minimum gap shall be flush with the edge of the outer crimp ring.</p> <p>NASA-STD-8739.4 [11.5]</p>
 <p style="text-align: center;">≥ 5 mm (0.20 in.)</p> <p style="text-align: center;">≥ 6 mm (0.20 in.)</p> <p style="text-align: center;">≤ 5 mm (0.20 in.)</p>	
<p style="text-align: center;">UNACCEPTABLE IMPROPER HEAT SHRINK LENGTH</p> <p>Heat shrink tubing conforms to crimp outline, but does not extend over the wire to provide any sealing or strain relief.</p> <p>NASA-STD-8739.4 [9.8.1], [9.9], [19.6.2.b.8]</p>	<p style="text-align: center;">UNACCEPTABLE IMPROPER STRAIN RELIEF/IMPROPER BENDS</p> <p>Wiring must be properly dressed to ensure a reliable termination. Wire bends shall meet minimum radius bend requirements.</p> <p>NASA-STD-8739.4 [7.3.22]</p>

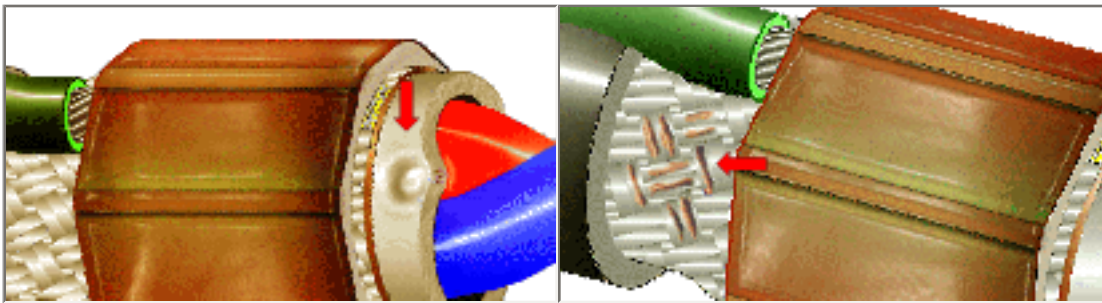

<p style="text-align: center;">UNACCEPTABLE</p> <p style="text-align: center;">INNER FERRULE DAMAGE/DISTORTION</p> <p>The inner ferrule shall be sized so that the inward distortion caused by the crimping process will not affect the insulated wires it surrounds.</p> <p>NASA-STD-8739.4 [11.5]</p>	<p style="text-align: center;">UNACCEPTABLE</p> <p style="text-align: center;">NICKED SHIELD STRANDS</p> <p>Nicked shield strands shall not exceed 10% of the total number of strands.</p> <p>NASA-STD-8739.4 [19.6.2.b.2]</p>
---	--

NASA WORKMANSHIP STANDARDS			
 <p>NATIONAL AERONAUTICS AND SPACE ADMINISTRATION JOHNSON SPACE CENTER HOUSTON, TEXAS USA 77058</p>	Released:	Revision:	Revision Date:
	03.30.2001		
	Book:	Section:	Page:
2	2.10	3	

CRIMPED TERMINATIONS SHIELD CRIMPS (cont.)	
<p style="text-align: center;">UNACCEPTABLE</p> <p style="text-align: center;">UNEVEN SHIELD COVERAGE</p> <p>The shield braid shall be dressed to provide uniform coverage and dispersion. Uneven coverage may result in electrical interference in sensitive circuits and may interfere with the reliability of the crimp assembly.</p> <p>Best Workmanship Practice</p>	

NASA WORKMANSHIP STANDARDS			
 NATIONAL AERONAUTICS AND SPACE ADMINISTRATION JOHNSON SPACE CENTER HOUSTON, TEXAS USA 77058	Released: 03.30.2001	Revision:	Revision Date:
	Book: 2	Section: 2.10	Page: 4



[Need a printed copy?](#)
(May take a while to load.)

Requires Adobe Reader.



[Need Adobe Reader?](#)
[Click here to download.](#)

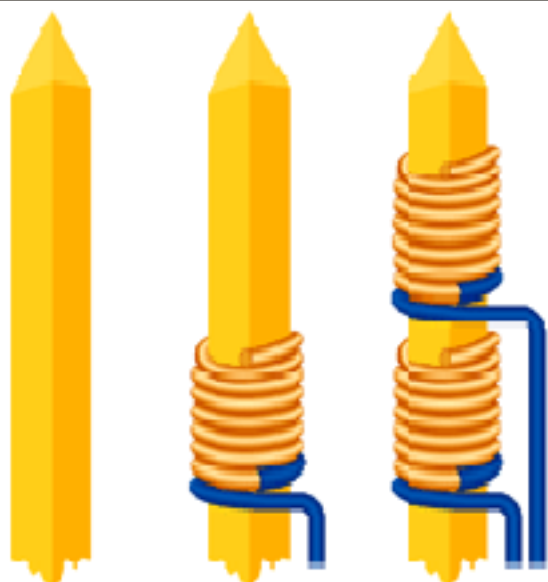
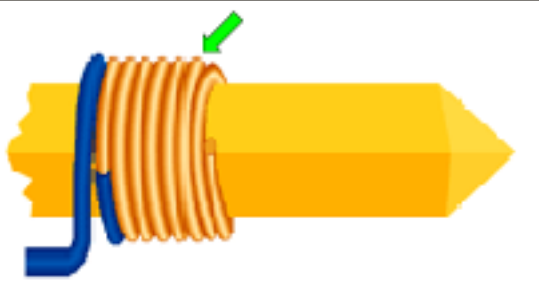
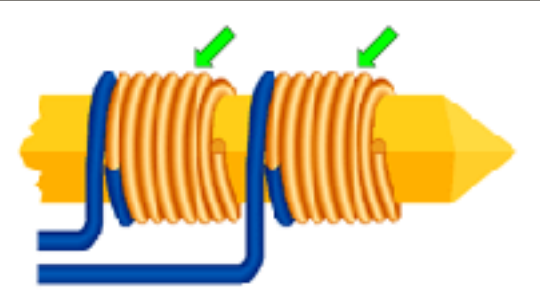
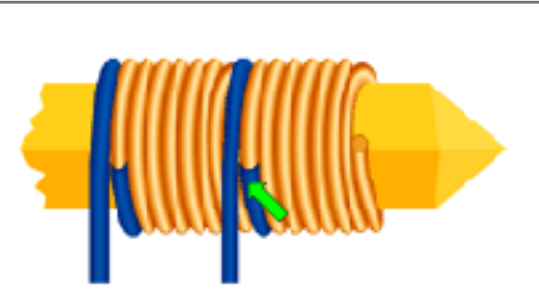
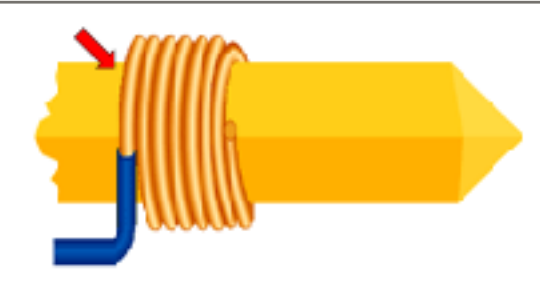

[Questions? Suggestions?](#)

DISCRETE WIRING SOLDERLESS WRAPPED ELECTRICAL CONNECTIONS-WIRE WRAP			
		<p>WIRE WRAPPING</p> <p>Solderless wrapped terminations are made by helically wrapping a solid uninsulated wire, around a specially designed termination post, to produce a mechanically and electrically stable connection.</p> <p><u>Class A:</u> Class A provides improved vibration characteristics, and is the required wrap style for spaceflight hardware applications. This wrap configuration, requires 1/2 to 1-1/2 turns of insulated wire be in contact with a minimum of three (3) corners of the wrap post, in addition to the uninsulated wraps.</p> <p><u>Class B:</u> Class B wraps are prohibited.</p>	
			
<p>ACCEPTABLE CLASS A – SINGLE TERMINATION</p> <p>The termination has the required number of insulated and uninsulated turns of wire, and is clean and free of foreign material.</p> <p>MIL-STD-1130B [4.1]</p>	<p>ACCEPTABLE CLASS A – MULTIPLE TERMINATIONS</p> <p>The terminations are properly spaced, with each having the required number of insulated and uninsulated turns of wire, and are clean and free of foreign material.</p> <p>MIL-STD-1130B [4.1]</p>		
			
<p>ACCEPTABLE OVERLAPPED TURNS</p> <p>The insulated conductor overwrap does not exceed one (1) turn, and the termination wrap is tight.</p> <p>MIL-STD-1130B [5.3.2.1 b]</p>	<p>UNACCEPTABLE CLASS B</p> <p>Class B terminations, characterized by the absence of insulated turns, are prohibited.</p> <p>Best Workmanship Practice</p>		
NASA WORKMANSHIP STANDARDS			
	Released: 03.31.2000	Revision: A	Revision Date: 03.30.2001



DISCRETE WIRING SOLDERLESS WRAPPED ELECTRICAL CONNECTIONS-WIRE WRAP (cont.)	
<p>UNACCEPTABLE INSUFFICIENT INSULATION WRAP</p> <p>The insulated section of the termination must be in contact with a minimum of three (3) corners of the wrappost.</p> <p>MIL-STD-1130B [5.3.2.1 a]</p>	<p>UNACCEPTABLE OVERLAPPING WRAPS</p> <p>The overlapping wrap must not exceed one (1) complete turn over the last turn of uninsulated wire in a termination directly below it on the wrappost.</p> <p>MIL-STD-1130B [5.3.2.1 b]</p>
<p>UNACCEPTABLE IMPROPER POSITION - SINGLE WRAP</p> <p>The first wrap should be located as low on the post as practical, providing sufficient space for additional terminations later.</p> <p>MIL-STD-1130B [5.3.2.1 b]</p>	<p>UNACCEPTABLE IMPROPER POSITION - MULTIPLE WRAP</p> <p>Terminations in a multiple wrap configuration must be properly positioned to ensure the wraps are completed within the defined termination area of the wrappost.</p> <p>MIL-STD-1130B [5.3.2.1 b]</p>

<p>UNACCEPTABLE INSUFFICIENT TURNS</p> <p>The uninsulated section of the termination shall have the minimum number of complete turns, as specified by MIL-STD-1130B, or as noted on the engineering documentation.</p> <p>MIL-STD-1130B [5.3.2]</p>	<p>UNACCEPTABLE END TAIL</p> <p>An end tail is the end of the last turn of wire that is protruding in a tangential direction from the surface of the wrappost. End tails present a risk of shorting.</p> <p>MIL-STD-1130b [5.3.2.1.d]</p>
--	--

NASA WORKMANSHIP STANDARDS			
 <p>NATIONAL AERONAUTICS AND SPACE ADMINISTRATION JOHNSON SPACE CENTER HOUSTON, TEXAS USA 77058</p>	Released: 03.31.2000	Revision: A	Revision Date: 03.30.2001
	Book: 3	Section: 3.01	Page: 2

DISCRETE WIRING
SOLDERLESS WRAPPED ELECTRICAL CONNECTIONS-WIRE WRAP
(cont.)

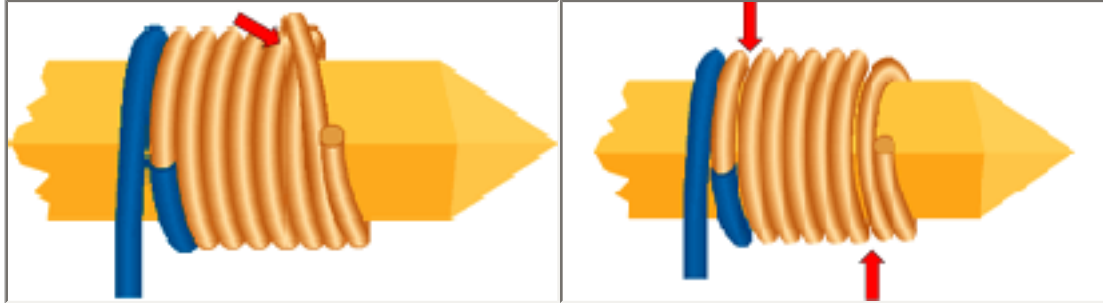

<p>UNACCEPTABLE OVERWRAP</p> <p>Overlapping wraps reduce the reliability of the termination and may result in severed wraps.</p> <p>MIL-STD-1130B [5.3.2.1 j]</p>	<p>UNACCEPTABLE SPIRAL WRAP</p> <p>The space between adjacent wrap turns shall not exceed one-half uninsulated conductor diameter. The sum of all gaps shall not exceed one wire diameter, excluding the first and last turn.</p> <p>MIL-STD-1130B [5.3.2.1 f]</p>
--	---

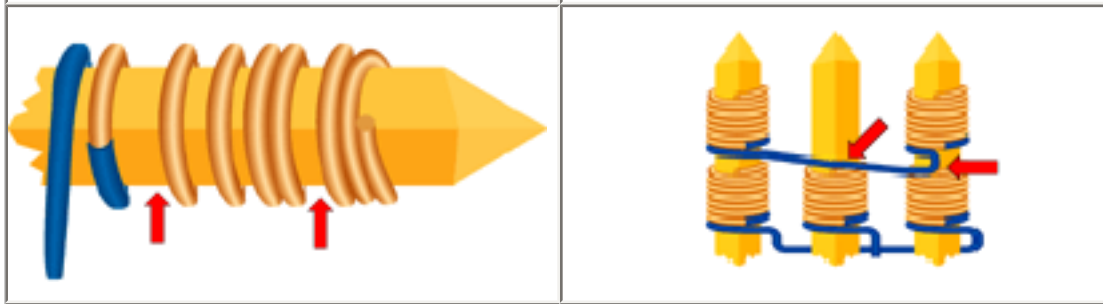

<p>UNACCEPTABLE OPEN WRAP</p> <p>An open wrap is an indicator of an improper termination process and may reduce the reliability of the termination.</p> <p>MIL-STD-1130B [5.3.2.1 f]</p>	<p>UNACCEPTABLE IMPROPER ROUTING</p> <p>The wire shall not be routed in any manner that will tend to unwrap the termination, and shall be routed around and between the wrapposts in a manner that prevents shorting to adjacent wrapposts.</p> <p>MIL-STD-1130B [5.3.2.1 g]</p>
---	---

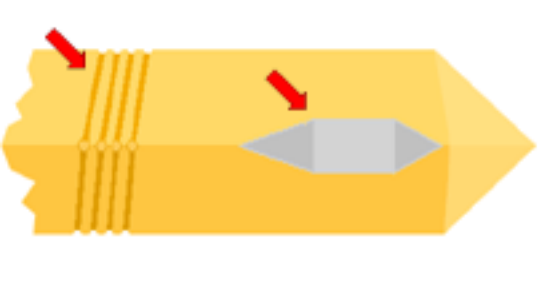
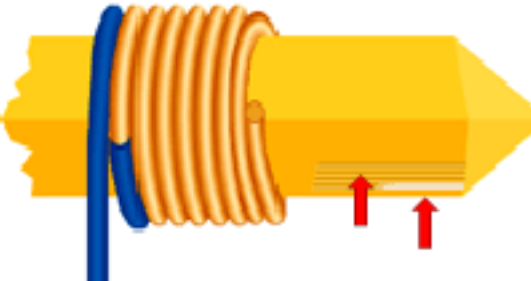

	
<p style="text-align: center;">UNACCEPTABLE DAMAGED WRAPPOST</p> <p>The wrappost shall not exhibit evidence of cracking, flaking plating, bending, excessive twisting, gouging or exposed base metal.</p> <p>MIL-STD-1130B [5.3.2.1 a]</p>	<p style="text-align: center;">UNACCEPTABLE DAMAGED WRAPPOST</p> <p>The wrappost shall not exhibit evidence of cracking, flaking plating, bending, excessive twisting, gouging or exposed base metal after wire wrapping.</p> <p>Best Workmanship Practices</p>

NASA WORKMANSHIP STANDARDS

	<p>NATIONAL AERONAUTICS AND SPACE ADMINISTRATION JOHNSON SPACE CENTER HOUSTON, TEXAS USA 77058</p>	<p>Released: 03.31.2000</p>	<p>Revision: A</p>	<p>Revision Date: 03.30.2001</p>
		<p>Book: 3</p>	<p>Section: 3.01</p>	<p>Page: 3</p>

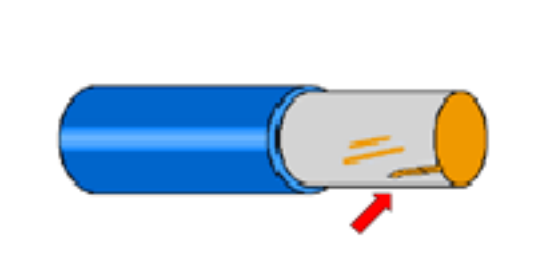
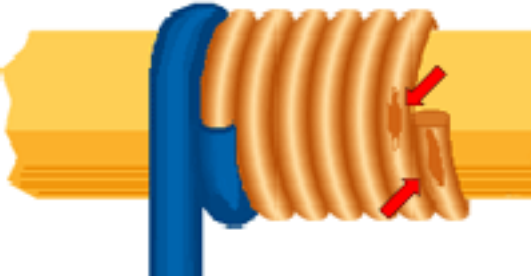
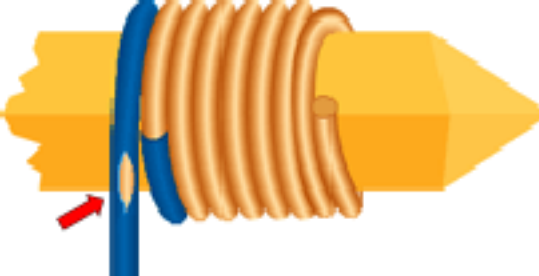
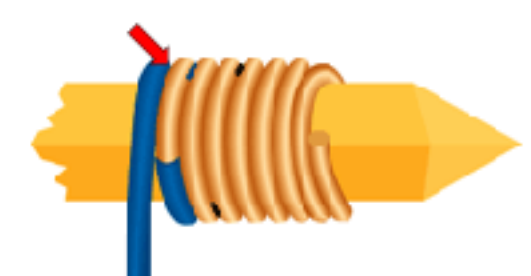
**DISCRETE WIRING
SOLDERLESS WRAPPED ELECTRICAL CONNECTIONS-WIRE WRAP
(cont.)**

	
<p style="text-align: center;">UNACCEPTABLE DAMAGED CONDUCTOR</p> <p>After removal of the insulation, the conductor shall not exhibit nicks, cuts, exposed base metal, ringing or reduction of cross-sectional area. Burnishing of the wire surface is acceptable.</p> <p>MIL-STD-1130B [5.3.2]</p>	<p style="text-align: center;">UNACCEPTABLE DAMAGED CONDUCTOR</p> <p>After wrapping, the conductor shall not exhibit nicks, cuts, exposed base metal, ringing or reduction of cross-sectional area. Burnishing of the wire surface is acceptable.</p> <p>Best Workmanship Practice</p>
	

<p style="text-align: center;">UNACCEPTABLE DAMAGED INSULATION</p> <p>Cut, crushed, gouged, damaged or nicked insulation may result in reduced electrical isolation and/or short circuits. Slight scuffing or discoloration is acceptable.</p> <p>Best Workmanship Practice</p>	<p style="text-align: center;">UNACCEPTABLE CONTAMINATION</p> <p>Contamination reduces the reliability of the termination.</p> <p>Best Workmanship Practice</p>
	
<p style="text-align: center;">UNACCEPTABLE STRANDED CONDUCTOR</p> <p>The use of standard conductor for wire wrapping is prohibited.</p> <p>Best Workmanship Practice</p>	<p style="text-align: center;">UNACCEPTABLE SILVER UNDERPLATING</p> <p>The use of wrapposts with silver underplating is prohibited. Gold plating over nickel is preferred.</p> <p>MIL-STD-1130B [5.3.2.1 a]</p>

NASA WORKMANSHIP STANDARDS

 <p>NATIONAL AERONAUTICS AND SPACE ADMINISTRATION JOHNSON SPACE CENTER HOUSTON, TEXAS USA 77058</p>	<p>Released: 03.31.2000</p>	<p>Revision: A</p>	<p>Revision Date: 03.30.2001</p>
	<p>Book: 3</p>	<p>Section: 3.01</p>	<p>Page: 4</p>



[Need a printed copy?](#)
(May take a while to load.)
Requires Adobe Reader.



[Need Adobe Reader?](#)
[Click here to download.](#)



[Questions? Suggestions?](#)

DISCRETE WIRING
JUMPER WIRES

JUMPER WIRES

Jumper wires (a.k.a.: haywires) are used to facilitate minor circuit modifications to printed wiring assemblies (PWA), rather than redesign and manufacture a new board. While their use is an accepted practice, the customer must grant approval prior to their use and installation. Jumper wires are usually solid, insulated copper conductor with tin/lead plating (i.e.: wire wrap wire), although jumpers less than 25mm (0.984 in.) may be uninsulated, provided the jumper is not liable to short between lands or component leads. Silver-plated and/or stranded wire shall not be used.

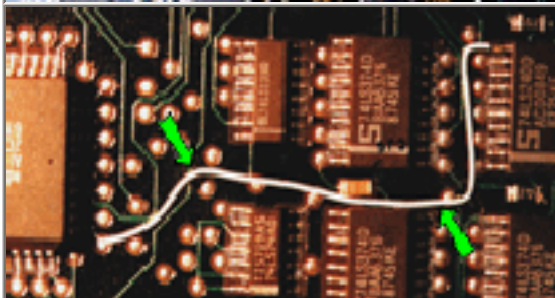

PREFERRED
COMPONENT TERMINATION SIDE

Wire route is the shortest path. Wire does not pass over or under components, or pass over any land or via used as a test point. Sufficient slack to allow relocation during component replacement.

[Best Workmanship Practice](#)

PREFERRED
SOLDER TERMINATION SIDE

Wire route is the shortest path. Wire does not cross component footprints or lands, except where unavoidable. Wire does not pass over any land or via used as a test point.

[Best Workmanship Practice](#)

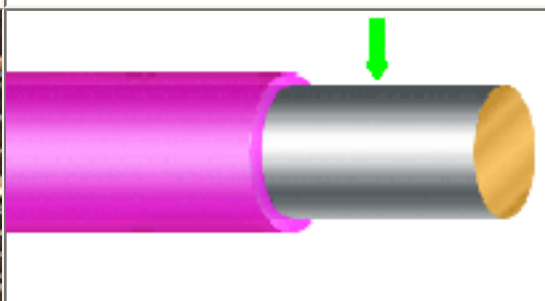
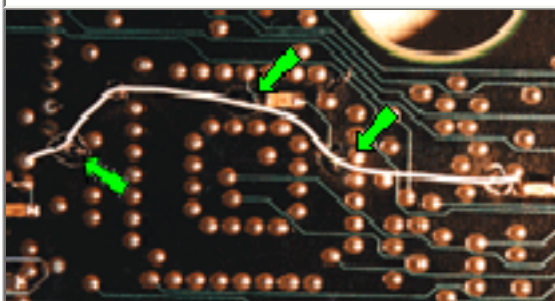

MANDATORY
STAKING

Jumper wire is staked at intervals specified by engineering documentation. The wire is staked at all changes of direction to restrict movement and as close to the solder termination as possible.

[NASA-STD-8739.1 \[9.2.4 \]](#)

MANDATORY
SOLID, INSULATED CONDUCTOR

Jumper wires shall be solid, insulated copper conductor with tin/lead plating (i.e.: wire wrap wire). Stranded, silver-plated wire shall not be used.

[Best Workmanship Practice](#)

NASA WORKMANSHIP STANDARDS

Released:
03.30.2001

Revision:

Revision Date:



DISCRETE WIRING
 JUMPER WIRES (cont.)



ACCEPTABLE
 COMPONENT LEAD TERMINATION

The termination shall be wrapped a minimum of 90°, exhibit proper insulation clearance, the outline shall be evident in the fillet, and shall not violate minimum electrical spacing.

[Best Workmanship Practice](#)



ACCEPTABLE
 LAP TERMINATION, GULL WING SMT

The jumper wire termination shall be a minimum of 75% of the lead length, as measured between the toe and knee, and shall not extend past the top of the component body.

[Best Workmanship Practice](#)

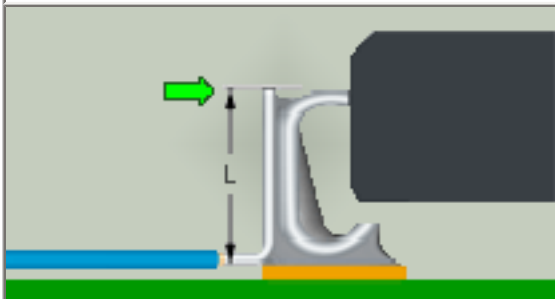

PREFERRED
 LAP TERMINATION, J-LEAD SMT

The jumper wire termination length shall be equal to the lead height (L), and shall not extend past the top of the component body.

[Best Workmanship Practice](#)

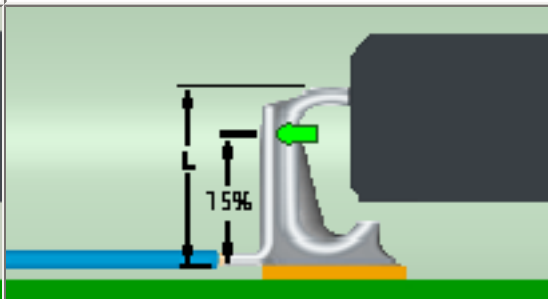

ACCEPTABLE
 LAP TERMINATION, J-LEAD SMT
 (MINIMUM)

The jumper wire termination length shall be a minimum of 75% of the lead height (L), and shall not extend past the top of the component body.

[Best Workmanship Practice](#)

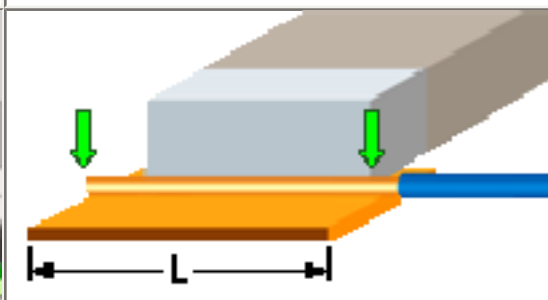

<p>ACCEPTABLE LAP TERMINATION, PTH</p> <p>The termination shall exhibit a lap solder joint a minimum of 75% of lead length, proper insulation spacing, a discernable outline and not violate minimum electrical spacing requirements.</p> <p>Best Workmanship Practice</p>	<p>ACCEPTABLE LAP TERMINATION, SMT</p> <p>The jumper wire termination shall be parallel to the longest dimension of the pad, with the solder fillet equal to the land width (L).</p> <p>Best Workmanship Practice</p>
--	---

NASA WORKMANSHIP STANDARDS			
 <p>NATIONAL AERONAUTICS AND SPACE ADMINISTRATION JOHNSON SPACE CENTER HOUSTON, TEXAS USA 77058</p>	Released: 03.30.2001	Revision:	Revision Date:
	Book: 3	Section: 3.02	Page: 2

**DISCRETE WIRING
JUMPER WIRES (cont.)**

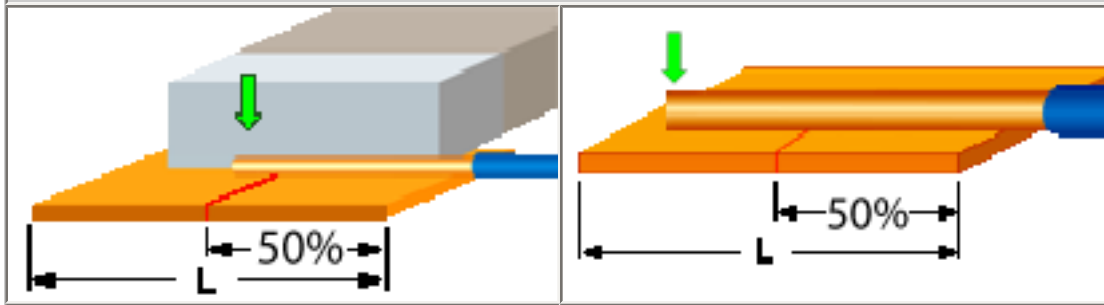

<p>ACCEPTABLE LAP TERMINATION, SMT (MINIMUM)</p> <p>The jumper wire termination shall be parallel to the longest dimension of the pad, with the solder fillet $\geq 50\%$ of the land width (L).</p> <p>Best Workmanship Practice</p>	<p>ACCEPTABLE LAP TERMINATION - VACANT LAND/PAD</p> <p>The jumper wire termination shall be parallel to the longest dimension of the pad (L), shall be a minimum of 50% of the dimension (L), and shall not overhang the pad.</p> <p>Best Workmanship Practice</p>
--	--

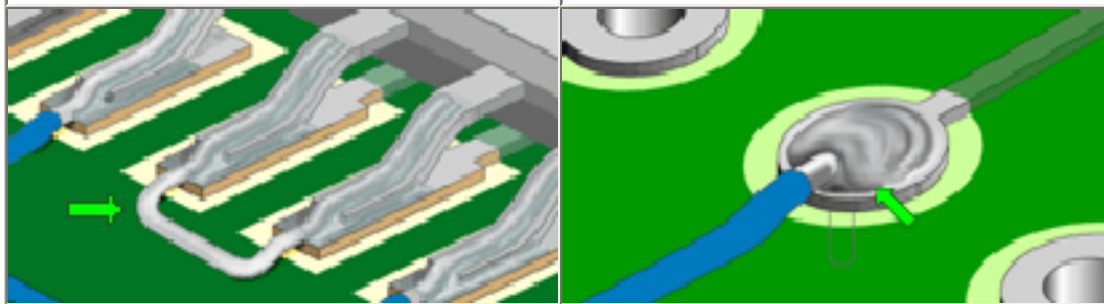

<p>ACCEPTABLE UNINSULATED WIRE</p> <p>Uninsulated jumper wires shall be less than 25mm (0.984 in.) long, and shall not violate minimum electrical spacing requirements. Silverplated, stranded wire shall not be used.</p> <p>Best Workmanship Practice</p>	<p>ACCEPTABLE VIA TERMINATION</p> <p>Jumper wires may be terminated and soldered into a via hole.</p> <p>Best Workmanship Practice</p>
---	--

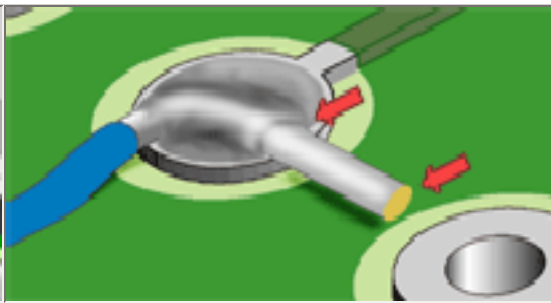
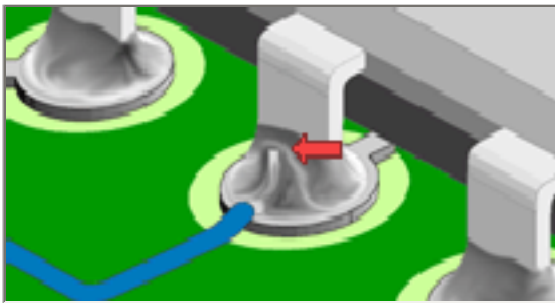

UNACCEPTABLE
IMPROPER LAP TERMINATION, PTH
 The lap joint is less than the required 75% of the lead length.
[Best Workmanship Practice](#)

UNACCEPTABLE
IMPROPER LAP TERMINATION
 The lap termination shall not overhang the land and/or violate minimum electrical spacing.
[Best Workmanship Practice](#)

NASA WORKMANSHIP STANDARDS

 NATIONAL AERONAUTICS AND SPACE ADMINISTRATION JOHNSON SPACE CENTER HOUSTON, TEXAS USA 77058	Released: 03.30.2001	Revision:	Revision Date:
	Book: 3	Section: 3.02	Page: 3

**DISCRETE WIRING
 JUMPER WIRES (cont.)**

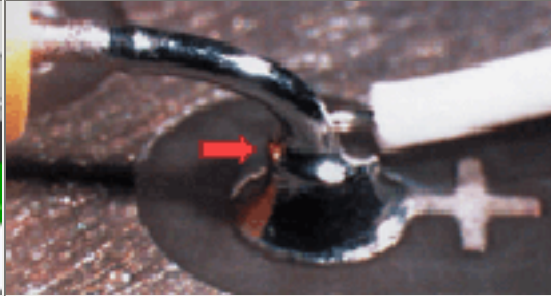

UNACCEPTABLE
**IMPROPER LAP TERMINATION
 GULL WING SMT**
 The jumper wire termination shall be a minimum of 75% fo the lead length (L), as measured between the toe and knee.
[Best Workmanship Practice](#)

UNACCEPTABLE
IMPROPER LEAD TERMINATION
 The termination wrap shall be a minimum of 90° and a maximum of 180°, with evidence of proper insulation gap and without overhanging the component termination.
[Best Workmanship Practice](#)

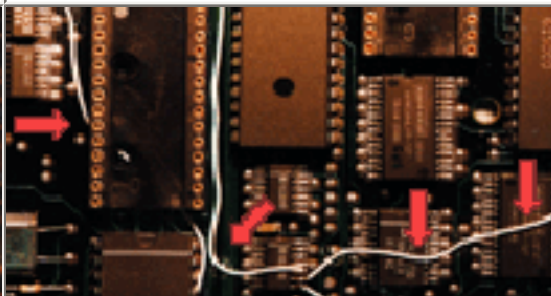
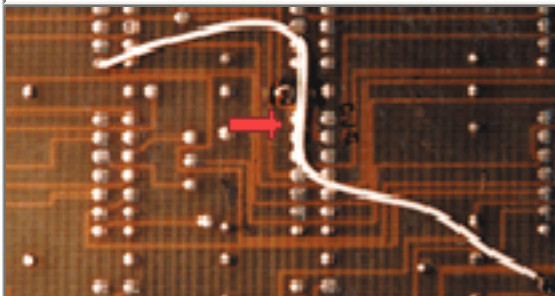

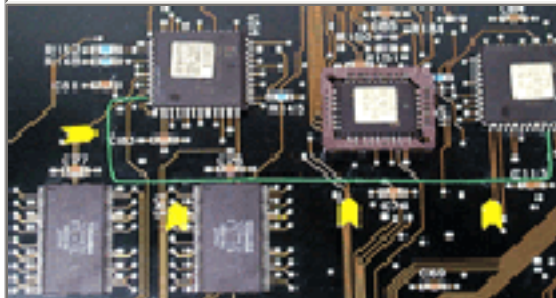
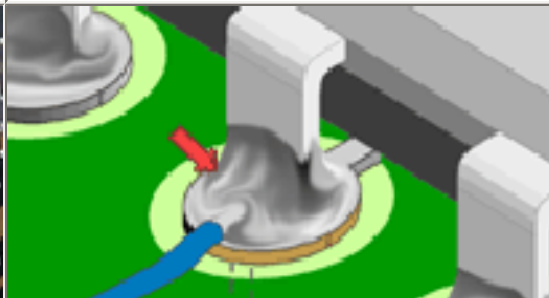
<p style="text-align: center;">UNACCEPTABLE IMPROPER ROUTING (OVER TEST POINTS)</p> <p>Jumper wires shall not be routed over circuit patterns or vias that are used as test points.</p> <p>Best Workmanship Practice</p>	<p style="text-align: center;">UNACCEPTABLE IMPROPER ROUTING (OVER/UNDER COMPONENTS)</p> <p>Jumper wires shall not be routed over or under components.</p> <p>Best Workmanship Practice</p>
	
<p style="text-align: center;">UNACCEPTABLE IMPROPER STAKING</p> <p>The jumper wire is not staked as specified. The wire is loose and can extend above the height of adjacent components.</p> <p>Best Workmanship Practice</p>	<p style="text-align: center;">UNACCEPTABLE IMPROPER TERMINATION (OCCUPIED PTH)</p> <p>Jumper wires shall not be terminated and soldered into plated-through holes (PTH) occupied by a component lead.</p> <p>Best Workmanship Practice</p>

NASA WORKMANSHIP STANDARDS

 <p>NATIONAL AERONAUTICS AND SPACE ADMINISTRATION JOHNSON SPACE CENTER HOUSTON, TEXAS USA 77058</p>	Released: 03.30.2001	Revision:	Revision Date:
	Book: 3	Section: 3.02	Page: 4



[Need a printed copy?](#)
(May take a while to load.)
Requires Adobe Reader.



[Need Adobe Reader?](#)
[Click here to download.](#)



[Questions? Suggestions?](#)

DISCRETE WIRING
DEADBUGS

DEADBUGS

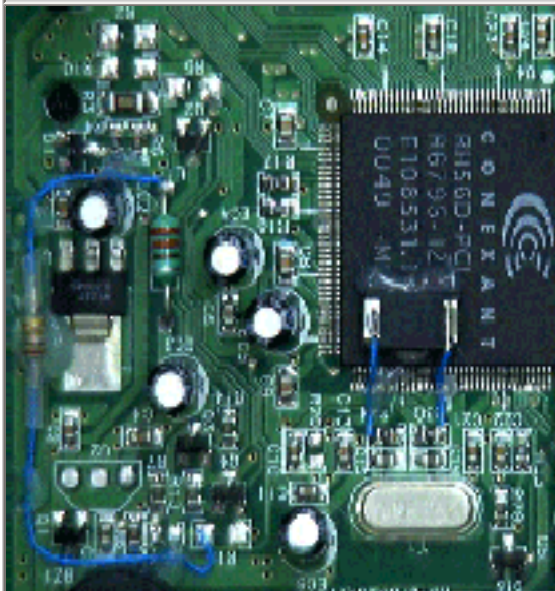

The term "Deadbugs" is an industry nickname for the discrete components added and wired into a printed wiring assembly (PWA) to facilitate active circuit modifications, rather than redesign and manufacture a new board. The nickname comes from their general appearance on the board: upside down, with their termination leads (legs) up in the air - like a dead bug.

While their use is an accepted practice, the customer must grant approval prior to their use and installation.

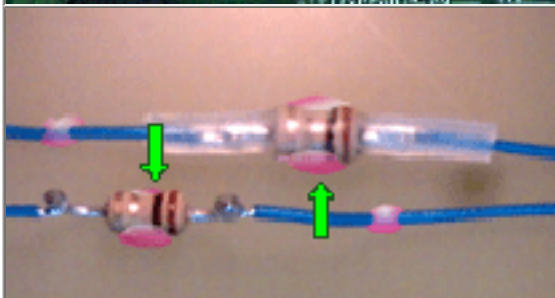

PREFERRED
AXIAL-LEADED COMPONENT

Component is properly mounted. Lead bends are within limits. Terminations are properly wrapped. The solder joints meet all minimum requirements. Jumper wires have appropriate stress relief.

[Best Workmanship Practice](#)

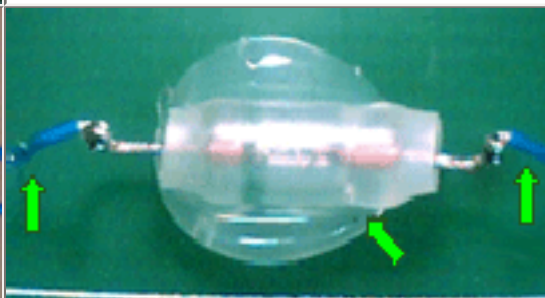

PREFERRED
GLASS-BODIED COMPONENT

Component is covered with a transparent resilient sleeving, and properly mounted. Lead bends are within limits. Terminations are properly wrapped. The solder joints meet all minimum requirements. Jumper wires have appropriate stress relief.

[Best Workmanship Practice](#)

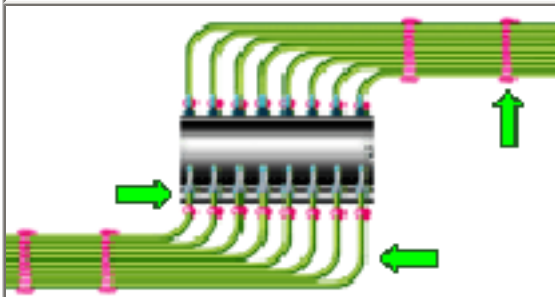

PREFERRED
DUAL-INLINE PACKAGE (DIP)

Component is properly mounted and terminated. Jumper wires are properly terminated, with appropriate stress relief. The solder joints meet all minimum requirements.

[Best Workmanship Practice](#)



PREFERRED
RADIAL-LEADED COMPONENT

Component is properly mounted and terminated. Lead bends are within limits. Terminations are properly wrapped. The solder joints meet all minimum requirements. Jumper wires have appropriate stress relief.

[Best Workmanship Practice](#)

NASA WORKMANSHIP STANDARDS

Released:
05.31.2002

Revision:

Revision Date:



DISCRETE WIRING
 DEADBUGS (cont.)

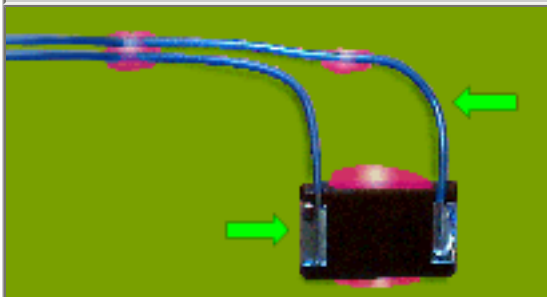

PREFERRED
 SURFACE MOUNT TECHNOLOGY
 CHIP/MELF/METALLIZED TERMINALS

Component is properly mounted and terminated. Jumper wires are properly terminated, with appropriate stress relief. The solder joints meet all minimum requirements.

[Best Workmanship Practice](#)

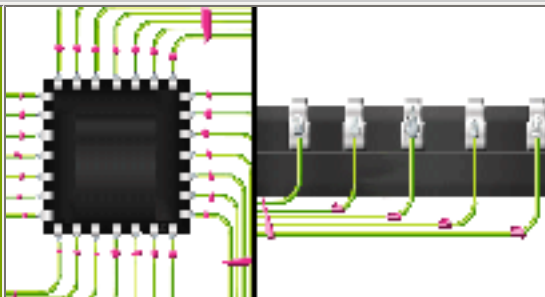

PREFERRED
 SURFACE MOUNT TECHNOLOGY
 GULL-WING/J-LEAD/ LEADED DEVICES

Component is properly mounted and terminated. Jumper wires are properly terminated, with appropriate stress relief. The solder joints meet all minimum requirements.

[Best Workmanship Practice](#)

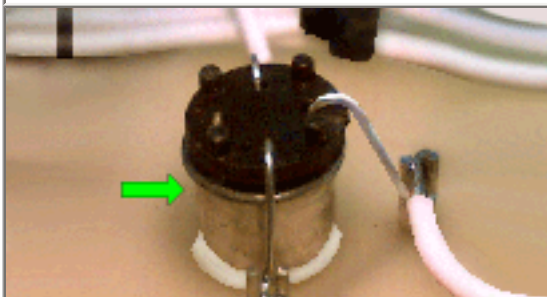

PREFERRED
 TO-CAN COMPONENT

Component is properly mounted and terminated. Lead bends are within limits. Terminations are properly wrapped. The solder joints meet all minimum requirements. Jumper wires have appropriate stress relief.

[Best Workmanship Practice](#)

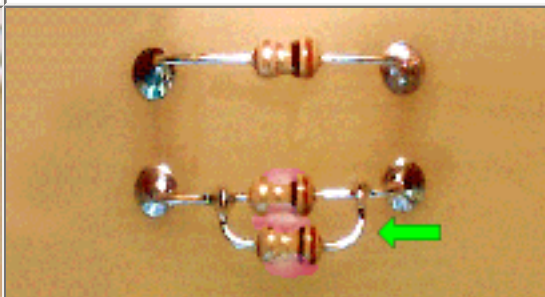

ACCEPTABLE
 AXIAL COMPONENT PIGGYBACK

Axial components may be piggybacked to axial components in a vertical or horizontal orientation, but shall be staked. Terminations shall meet minimum lead seal spacing, lead bend, wrap and solder fillet requirements.

[Best Workmanship Practice](#)

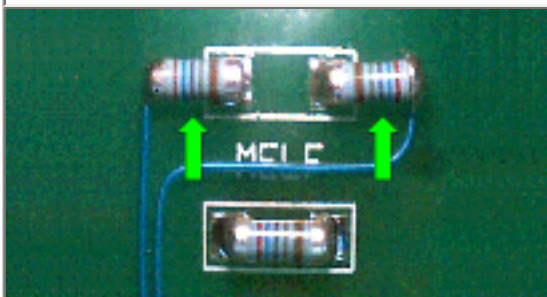

<p>ACCEPTABLE CHIP/MELF/METALLIZED TERMINALS ALTERNATE MOUNT</p> <p>Chip component mounting to a single pad is acceptable, provided the component is properly staked to prevent stress to the solder joints or the component body.</p> <p>Best Workmanship Practice</p>	<p>ACCEPTABLE PIGGYBACKING/STACKING SMT (3-5 SIDE) CHIP COMPONENTS</p> <p>The components are in vertical alignment, with no overhang. The terminations exhibit fully wetted solder fillets and the stack does not exceed two (2) components high.</p> <p>Best Workmanship Practice</p>
---	--

NASA WORKMANSHIP STANDARDS			
 <p>NATIONAL AERONAUTICS AND SPACE ADMINISTRATION JOHNSON SPACE CENTER HOUSTON, TEXAS USA 77058</p>	Released: 05.31.2002	Revision:	Revision Date:
	Book: 3	Section: 3.03	Page: 2

DISCRETE WIRING
DEADBUGS (cont.)

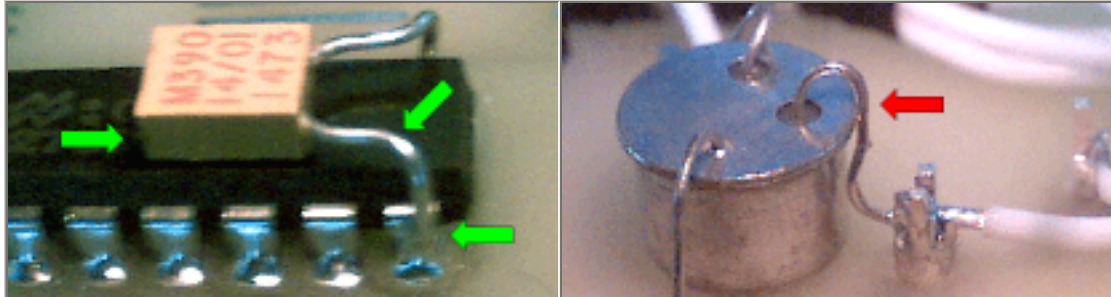

<p>ACCEPTABLE PIGGYBACKING/STACKING TO ICs AXIAL/RADIAL/SMT COMPONENTS</p> <p>IC piggybacking is acceptable when space and/or noise requirements prohibit more traditional placement methods. Component leads/jumper wires shall meet minimum bend requirements.</p> <p>Best Workmanship Practice</p>	<p>UNACCEPTABLE IMPROPER LEAD DRESS</p> <p>Dead-bugged components shall be mounted and dressed in a manner that prevents shorting of the leads to the component case (pictured) or to other conductors.</p> <p>Best Workmanship Practice</p>
---	---

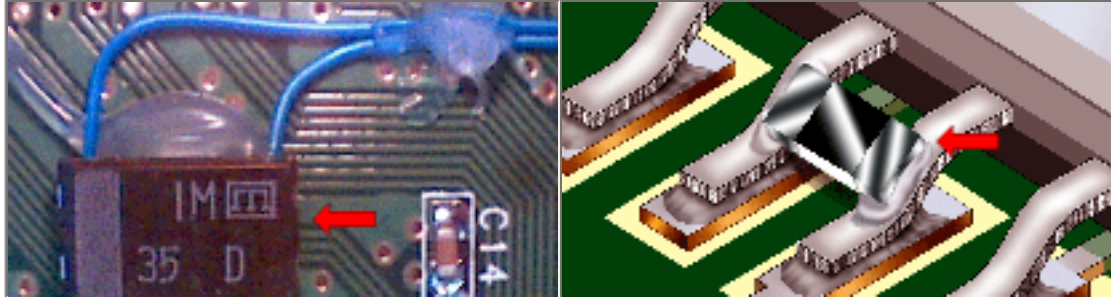

<p>UNACCEPTABLE IMPROPER MOUNTING ORIENTATION</p> <p>Components shall be mounted with the leads in an orientation that ensures the terminations meet minimum electrical spacing requirements. As pictured, the component terminals are resting on exposed circuitry and vias.</p> <p>Best Workmanship Practice</p>	<p>UNACCEPTABLE IMPROPER MOUNTING SMT COMPONENTS MOUNTED ON LEADS</p> <p>Chip and MELF devices shall not be directly mounted on component leads of integrated circuit (chip) packages.</p> <p>Best Workmanship Practice</p>
---	--

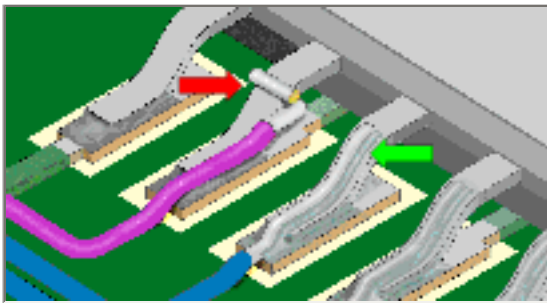

UNACCEPTABLE
IMPROPER SOLDER TERMINATION
LEADED DEVICES

Jumper wires shall be lap soldered to the device leads. Wrapped terminations place stress on the component lead, and may violate minimum lead-to-lead electrical spacing requirements.

[Best Workmanship Practice](#)

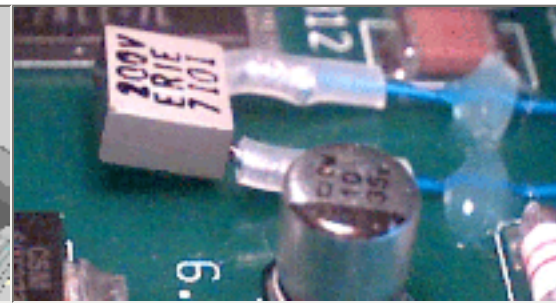

UNACCEPTABLE
IMPROPER STAKING

The component shall be secured with an adhesive material, per engineering documentation.

[Best Workmanship Practice](#)

NASA WORKMANSHIP STANDARDS



NATIONAL AERONAUTICS AND
SPACE ADMINISTRATION
JOHNSON SPACE CENTER
HOUSTON, TEXAS USA 77058

Released:
05.31.2002

Revision:

Revision Date:

Book:
3

Section:
3.03

Page:
3

DISCRETE WIRING
DEADBUGS (cont.)

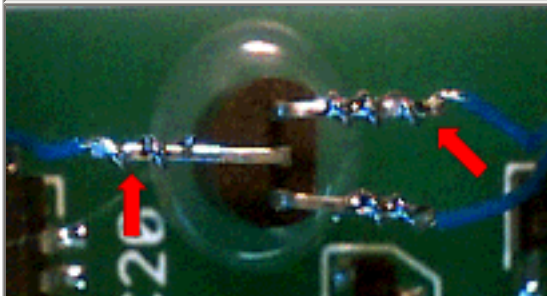

UNACCEPTABLE
IMPROPER TERMINATION WRAP

Jumper wires shall be wrapped at least 180° to 270° around the component lead prior to soldering, and shall not be located closer than one (1) lead diameter to end of the component lead.

[Best Workmanship Practice](#)

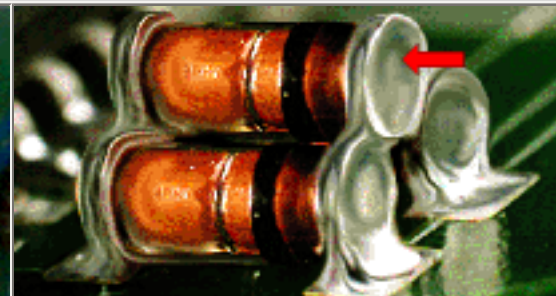

UNACCEPTABLE
PIGGY-BACK/STACKING
CYLINDRICAL/MELF COMPONENTS

The piggy-backing/stacking of cylindrical/glass-bodied/MELF components is not recommended.

[Best Workmanship Practice](#)

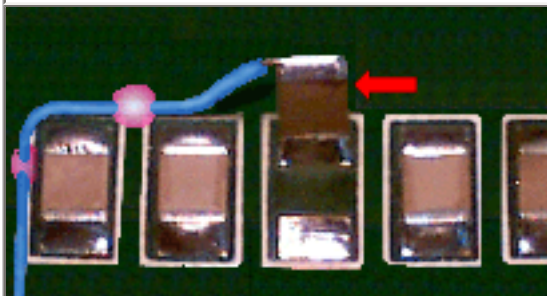

UNACCEPTABLE
TOMBSTONED TERMINATION

Deadbugged components shall be mounted parallel to and in contact with the base laminate, or base component (if applicable). Tombstoning places unacceptable stress on the component/solder pad termination.

[Best Workmanship Practice](#)

NASA WORKMANSHIP STANDARDS			
 NATIONAL AERONAUTICS AND SPACE ADMINISTRATION JOHNSON SPACE CENTER HOUSTON, TEXAS USA 77058	Released: 05.31.2002	Revision:	Revision Date:
	Book: 3	Section: 3.03	Page: 4



[Need a printed copy?](#)
(May take a while to load.)

Requires Adobe Reader.



[Need Adobe Reader?](#)
[Click here to download.](#)



[Questions? Suggestions?](#)

CABLE AND HARNESS
GENERAL REQUIREMENTS

CABLE AND HARNESS
GENERAL REQUIREMENTS

Often the most overlooked and ignored component of any electrical/electronic design, cable and harnesses are essential to the accurate and rapid transmission of data and control signals.

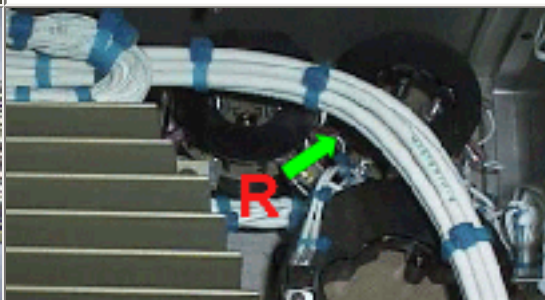
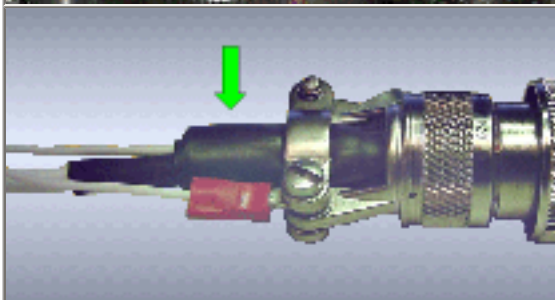

PREFERRED
BACKSHELL

Connector backshells shall be potted and molded, or use stress relief boots as required, in accordance with applicable engineering documentation.

[NASA-STD-8739.4 \[13.1.1.c\]](#)

PREFERRED
BEND RADIUS

Cables and harnesses shall not be subjected to bending forces resulting in radii less than the minimum specified for the most sensitive component (i.e.: coaxial, fiber, etc.) in the assembly.

[Best Workmanship Practice](#)

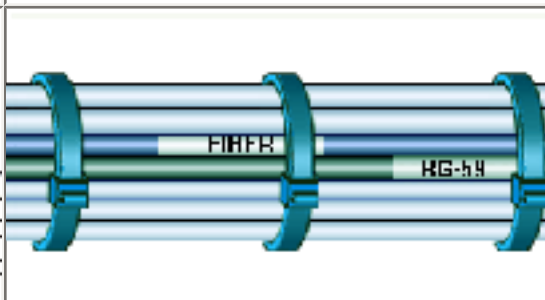
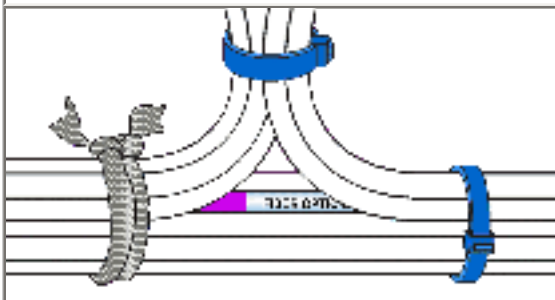

PREFERRED
COAXIAL/FIBER OPTIC CABLE
LOCATION

Harnesses should be designed so that coaxial/fiber optic cables are located at or near the bundle center to minimize flexure and to provide additional protection.

[Best Workmanship Practice](#)

PREFERRED
COAXIAL/FIBER OPTIC CABLES

Coaxial cable (flexible, semi-rigid, rigid) and fiber optic cables shall exhibit a neatly organized layout, with smooth bends and sufficient stress relief.

[Best Workmanship Practice](#)

NASA WORKMANSHIP STANDARDS



NATIONAL AERONAUTICS AND
SPACE ADMINISTRATION
JOHNSON SPACE CENTER
HOUSTON, TEXAS USA 77058

Released:
04.05.2002

Revision:

Revision Date:

	Book: 4	Section: 4.01	Page: 1
--	------------	------------------	------------

**CABLE AND HARNESS
GENERAL REQUIREMENTS (cont.)**



**PREFERRED
CONNECTOR STYLE**

Connectors shall be straight, right-angle or flange-mount. The use of right-angle connectors shall be minimized and restricted to applications where stress-free mounting of the cable assembly can be assured.

[Best Workmanship Practice](#)



**PREFERRED
DISCRETE WIRE HARNESSES**

Harnesses exhibit a neatly organized layout with smooth bends and sufficient stress relief. Connector cable clamps and cable straps are properly set.

[NASA-STD-8739.4 \[19.6.1.e\]](#)

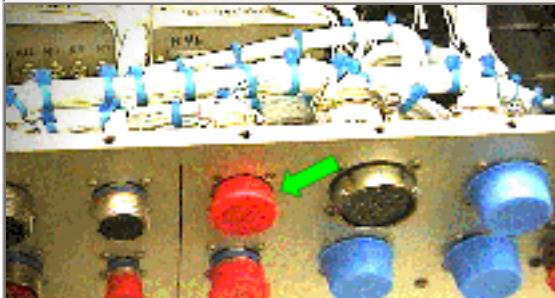

**PREFERRED
DUST CAPS**

The mating surfaces of all unmated connectors shall be protected by covers during storage, handling and installation. Connectors on ESD sensitive hardware shall be protected by ESD rated dust caps/covers.

[NASA-STD-8739.4 \[13.1.2\], \[16.2.4\], \[16.3.3\]](#)

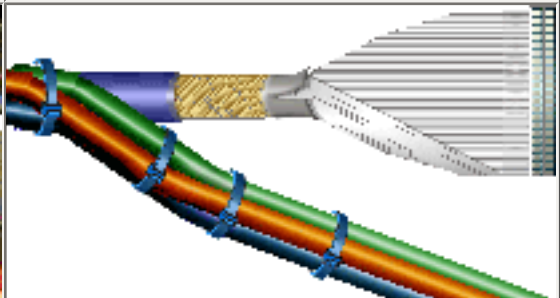

**PREFERRED
HYBRID CABLES/HARNESSES**

Hybrid cables/harnesses (copper/fiber optic/coaxial conductors) shall be designed to comply with the requirements of the most sensitive and demanding component (typically the fiber optic cable) in the assembly.

[Best Workmanship Practice](#)



**PREFERRED
IDENTIFICATION
CABLES/HARNESSES**

Each cable/harness shall be identified by a permanent label/markings.

[NASA-STD-8739.4 \[14.2.1\]](#)

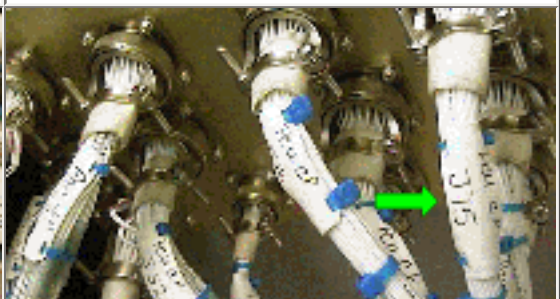

**PREFERRED
IDENTIFICATION
CONNECTOR**

Each connector shall be identified by a permanent label/markings affixed directly to the connector body, or to the cable adjacent to the connector.

[NASA-STD-8739.4 \[14.2.2\]](#)

NASA WORKMANSHIP STANDARDS			
 NATIONAL AERONAUTICS AND SPACE ADMINISTRATION JOHNSON SPACE CENTER HOUSTON, TEXAS USA 77058	Released: 04.05.2002	Revision:	Revision Date:
	Book: 4	Section: 4.01	Page: 2

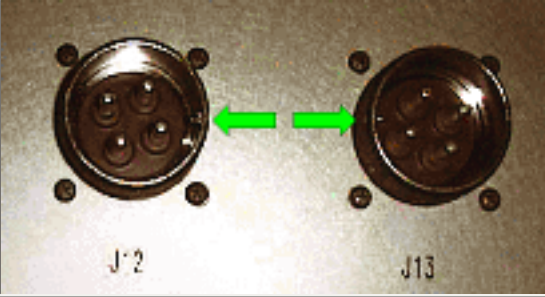
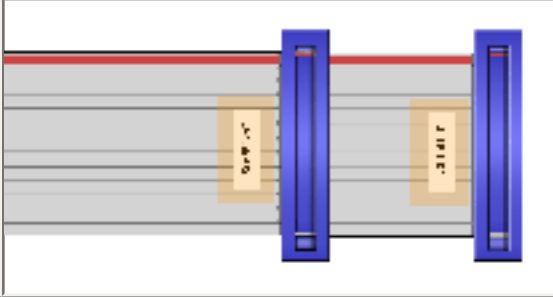
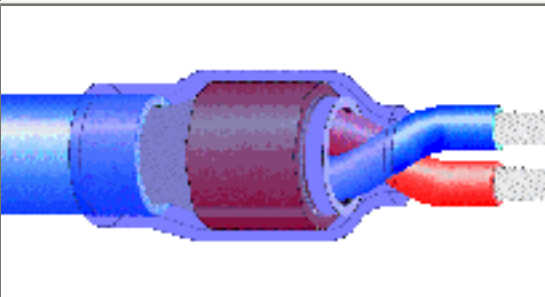
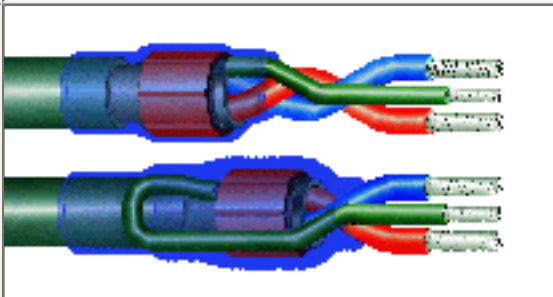
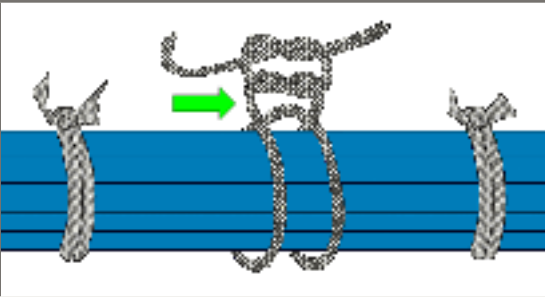
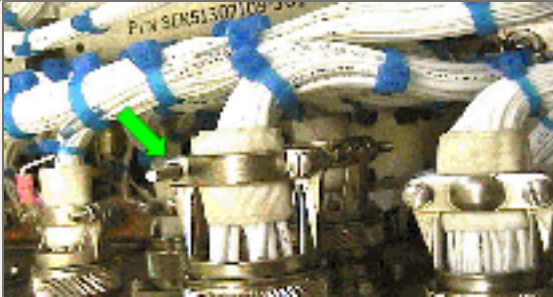
CABLE AND HARNESS GENERAL REQUIREMENTS (cont.)	
	
<p align="center">PREFERRED POLARIZATION/KEYING</p> <p>Interconnecting cables and harnesses shall be designed with physical constraints (keying, sizing, polarization, etc.) to prevent incorrect mating/interchanging with similar sized/colored connectors.</p> <p>NASA-STD-8739.4 [7.1]</p>	<p align="center">PREFERRED RIBBON CABLE</p> <p>The cable assembly meets dimensional, layout and design requirements and exhibits a smooth, flat profile with no visible damage to the connectors or the insulation. Connectors are properly aligned and seated.</p> <p>Best Workmanship Practice</p>
	
<p align="center">PREFERRED SHIELD TERMINATION - FLOATING</p> <p>Heat shrink tubing is properly installed, tightly shrunk and the termination is visible. Overlaps are of sufficient length to meet minimum electrical spacing.</p> <p>NASA-STD-8739.4 [9.8.1], [9.9], [11.5], [19.6.1]</p>	<p align="center">PREFERRED SHIELD TERMINATION - GROUNDED</p> <p>Heat shrink sections are properly installed, tightly shrunk and the termination is visible. Overlaps meet minimum electrical spacing. Ground wire exhibits proper bend radius and strain relief.</p> <p>NASA-STD-8739.4 [7.3.22], [9.8.1], [9.9], [11.5], [19.6.1]</p>
	

<p>ACCEPTABLE SPOT TIES</p> <p>Spot ties shall consist of a clove hitch, followed by a square or other similar non-slip knot (i.e.: surgeon, etc.).</p> <p>NASA-STD-8739.4 [9.2.2]</p>	<p>ACCEPTABLE BACKSHELL ASSEMBLY</p> <p>Connector backshells, adapters and clamps shall be assembled and torqued per engineering documentation.</p> <p>NASA-STD-8739.4 [13.5]</p>
---	--

NASA WORKMANSHIP STANDARDS			
 <p>NATIONAL AERONAUTICS AND SPACE ADMINISTRATION</p> <p>JOHNSON SPACE CENTER HOUSTON, TEXAS USA 77058</p>	Released: 04.05.2002	Revision:	Revision Date:
	Book: 4	Section: 4.01	Page: 3

**CABLE AND HARNESS
GENERAL REQUIREMENTS (cont.)**



<p>ACCEPTABLE BACKSHELL SCREW PROTRUSION</p> <p>Screws shall protrude a minimum of 1-1/2 threads beyond the threaded hardware (e.g., nut, clamp, etc.), but shall not violate minimum electrical spacing or snag requirements, unless otherwise specified by engineering documentation.</p> <p>Best Workmanship Practice</p>	<p>UNACCEPTABLE EXCESSIVE THREAD PROTRUSION</p> <p>Excess thread protrusion represents an assembly, interference and electrical separation problem, as well as adds unnecessary weight to the assembly.</p> <p>Best Workmanship Practice</p>
---	---

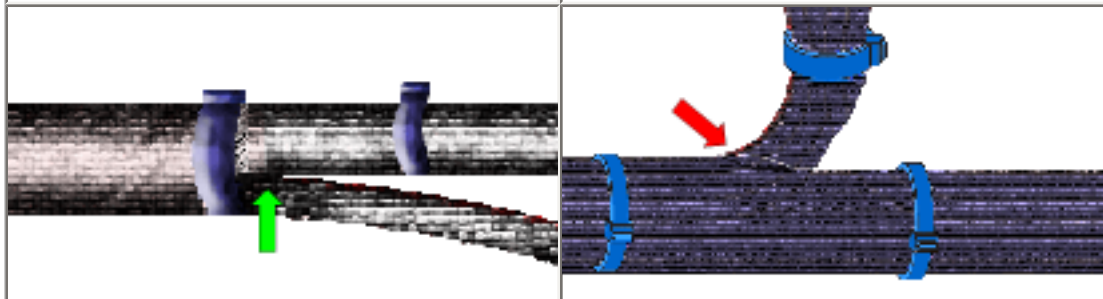

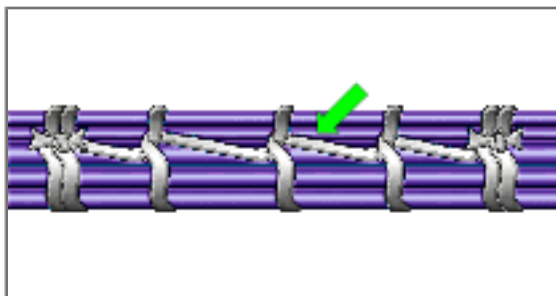
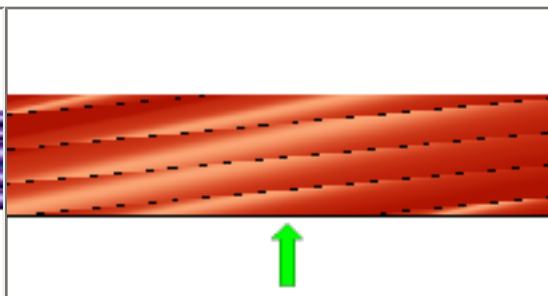

<p>ACCEPTABLE BREAKOUT DRESS W/ FABRIC BRAID</p> <p>Braiding shall be dressed to form a smooth profile across the breakout. Braiding shall not be split, slit or punctured to provide a breakout opening.</p> <p>NASA-STD-8739.4 [9.3]</p>	<p>UNACCEPTABLE SPLIT/SPLIT BRAIDING AT BREAKOUT</p> <p>Braiding shall not be split, slip or punctured to provide an opening at the breakout.</p> <p>NASA-STD-8739.4 [9.3]</p>
---	---

	
<p style="text-align: center;">ACCEPTABLE CABLE LACING RUNNING STITCH</p> <p>The lacing begins and ends with a knot. Wraps are properly spaced (relative to harness diameter) to maintain the wiring in a tight, neat bundle. Ends are properly trimmed.</p> <p>NASA-STD-8739.4 [9.2]</p>	<p style="text-align: center;">UNACCEPTABLE CABLE LAYUP</p> <p>Cables containing discrete conductors shall be fabricated in one or more layers, by winding the conductors together uniformly. Layup (twist) of each layer shall be 8-16 times the outer harness diameter.</p> <p>NASA-STD-8739.4 [7.3.20], [19.6.1.e.4]</p>

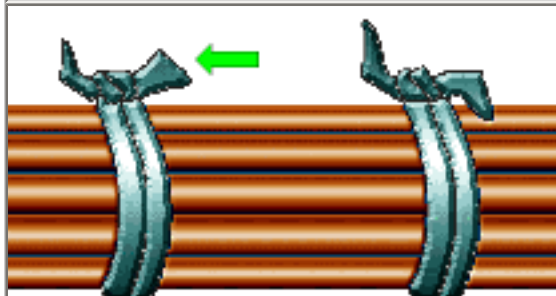
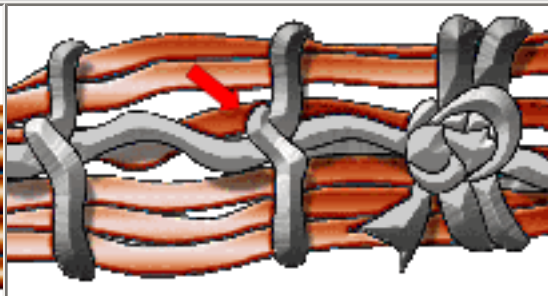
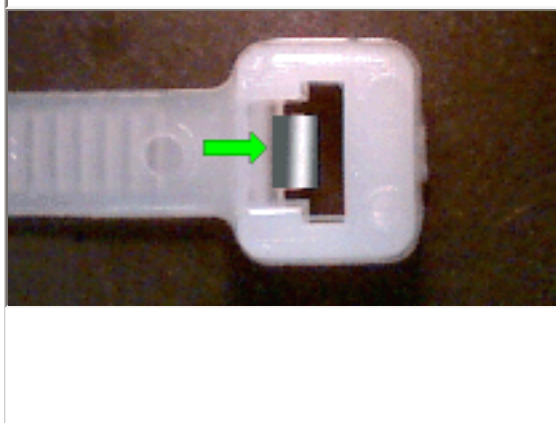
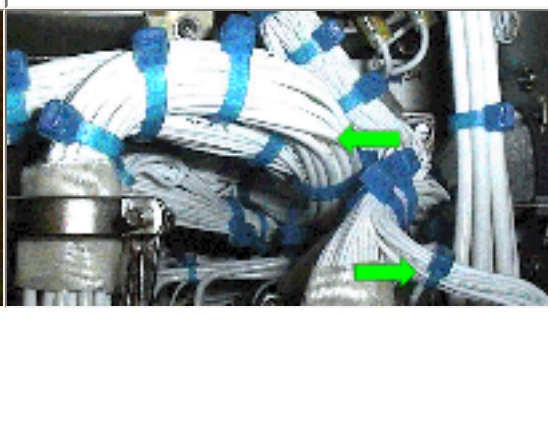
NASA WORKMANSHIP STANDARDS				
	<p>NATIONAL AERONAUTICS AND SPACE ADMINISTRATION JOHNSON SPACE CENTER HOUSTON, TEXAS USA 77058</p>	Released: 04.05.2002	Revision: 	Revision Date:
		Book: 4	Section: 4.01	Page: 4

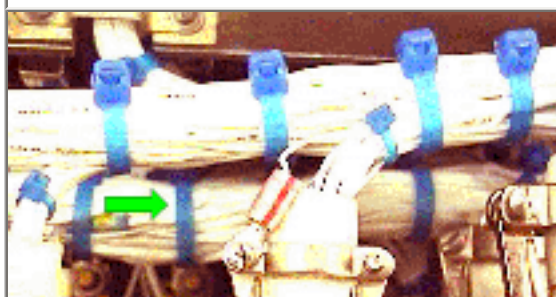
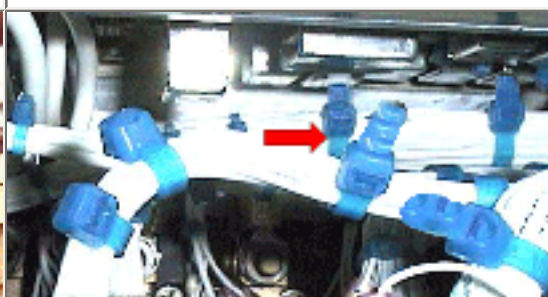
CABLE AND HARNESS GENERAL REQUIREMENTS (cont.)	
	
<p style="text-align: center;">ACCEPTABLE CABLE LACING SPOT TIES</p> <p>Ties are neat, tight and properly spaced (relative to harness diameter) to maintain the wiring in a tight, neat bundle. Ends are properly trimmed.</p> <p>NASA-STD-8739.4 [9.2.2]</p>	<p style="text-align: center;">UNACCEPTABLE LOOSE CABLE LACING</p> <p>The lacing has not been properly installed, resulting in a loose, unorganized bundle.</p> <p>NASA-STD-8739.4 [19.6.2.d.4]</p>
	

<p style="text-align: center;">ACCEPTABLE CABLE STRAPS/TIES</p> <p>Plastic straps should have metal tangs that lock securely into the ribbed portion of the strap.</p> <p>NASA-STD-8739.4 [7.3.4]</p>	<p style="text-align: center;">ACCEPTABLE CONDUCTOR DRESS</p> <p>All wires are dressed with even bends and sufficient strain relief. Conductor crossover is minimized.</p> <p>NASA-STD-8739.4 [19.6.1.e]</p>
	
<p style="text-align: center;">ACCEPTABLE CABLE TIES/TIE WRAPS</p> <p>The cable ties/tie wraps are sufficiently tight to prevent lateral movement along the cable bundle under normal handling, but can be rotated in place. Strap ends have been trimmed off square and flush with the face of strap head.</p> <p>NASA-STD-8739.4 [9.6]</p>	<p style="text-align: center;">UNACCEPTABLE UNTRIMMED CABLE TIES</p> <p>The strap end shall be trimmed off, flush with the back end of the strap head.</p> <p>NASA-STD-8739.4 [9.6], [19.6.2.d.5]</p>

NASA WORKMANSHIP STANDARDS			
 <p>NATIONAL AERONAUTICS AND SPACE ADMINISTRATION JOHNSON SPACE CENTER HOUSTON, TEXAS USA 77058</p>	Released: 04.05.2002	Revision:	Revision Date:
	Book: 4	Section: 4.01	Page: 5

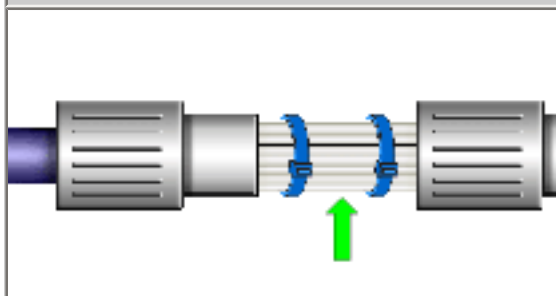
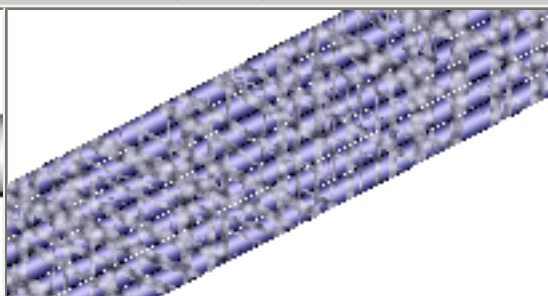
CABLE AND HARNESS GENERAL REQUIREMENTS (cont.)	
	
<p style="text-align: center;">ACCEPTABLE CONNECTOR SAVERS</p> <p>The use of connector savers is recommended. Connector savers shall meet the same requirements as a flight connector.</p> <p>NASA-STD-8739.4 [17.2.7]</p>	<p style="text-align: center;">ACCEPTABLE DIRECT WEAVE FABRIC BRAID</p> <p>Fabric braids woven directly on interconnecting harnesses or cables may be loose or tight. The finish shall be smooth, without gaps in coverage, and without frayed ends.</p> <p>NASA-STD-8739.4 [9.4]</p>

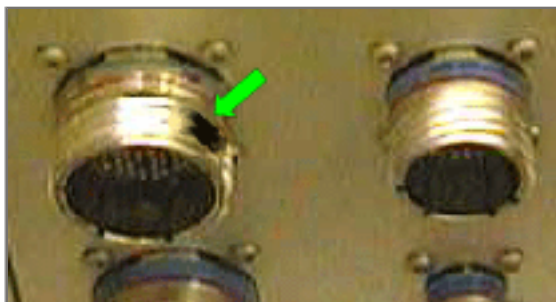
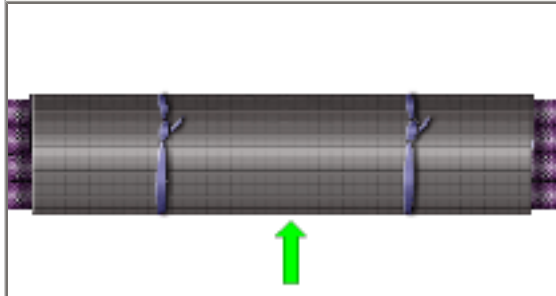
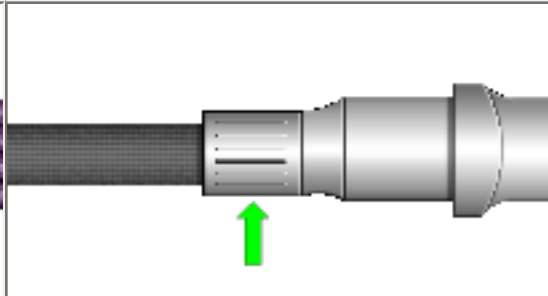

	
<p style="text-align: center;">ACCEPTABLE DISCOLORATION/SCUFFING CONNECTOR</p> <p>Slight scuffing or discoloration is acceptable, provided there is no impact to form, fit or function, and there is no exposure of base metal.</p> <p>Best Workmanship Practice</p>	<p style="text-align: center;">ACCEPTABLE DISCOLORATION/SCUFFING INSULATION</p> <p>The cable does not exhibit evidence of insulation damage, such as cuts, nicks, scrapes, crushing, cold flow or burns. Slight scuffing or discoloration is acceptable.</p> <p>NASA-STD-8739.4 [19.6.2.e.9]</p>
	
<p style="text-align: center;">ACCEPTABLE FABRIC BRAIDED SLEEVING</p> <p>Prewoven fabric (unvarnished) braid sleeving may be installed over the wire harness. Sleeving shall be snug, secured at both ends and shall not slide freely. Ends shall not be frayed or unraveled, and shall be tucked under.</p> <p>NASA-STD-8739.4 [9.3]</p>	<p style="text-align: center;">ACCEPTABLE FABRIC BRAID SLEEVING ALTERNATE END DRESS</p> <p>The end of the braid may be secured by connector clamps, other hardware or potting.</p> <p>NASA-STD-8739.4 [9.3.2]</p>

NASA WORKMANSHIP STANDARDS

 <p>NATIONAL AERONAUTICS AND SPACE ADMINISTRATION JOHNSON SPACE CENTER HOUSTON, TEXAS USA 77058</p>	Released: 04.05.2002	Revision:	Revision Date:
	Book: 4	Section: 4.01	Page: 6

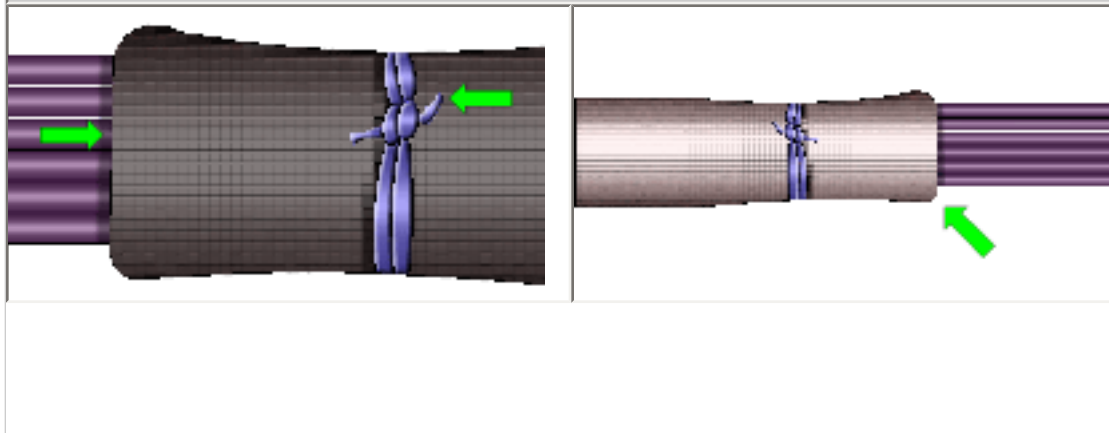
**CABLE AND HARNESS
GENERAL REQUIREMENTS (cont.)**

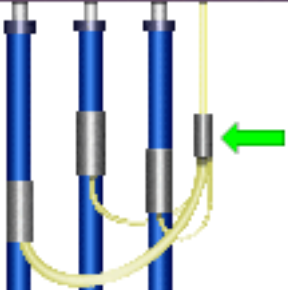
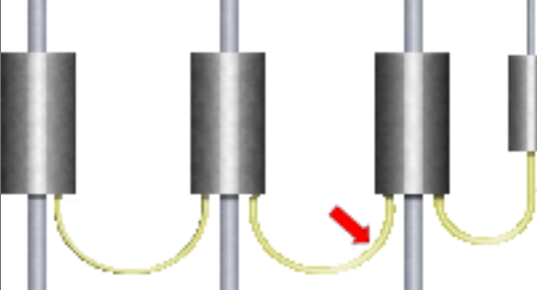

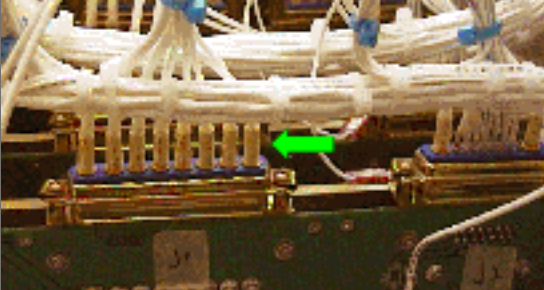
<p style="text-align: center;">ACCEPTABLE FABRIC BRAID SLEEVING BASIC END TERMINATION</p> <p>The end of the braid shall be tucked under and secured with a spot tie or plastic strap.</p> <p>NASA-STD-8739.4 [9.3.1]</p>	<p style="text-align: center;">ACCEPTABLE GLASS BRAID SLEEVING</p> <p>The ends of glass braid may be bonded by use of adhesive, and then secured by spot tie or other means to prevent movement on the wire bundle.</p> <p>NASA-STD-8739.4 [9.3.3]</p>
	
<p style="text-align: center;">ACCEPTABLE GROUP SHIELD TERMINATION</p> <p>Shield ground leads shall be terminated to a common ground point. No more than 4 conductors, plus a drain wire, shall be terminated in a single splice.</p> <p>NASA-STD-8739.4 [11.6]</p>	<p style="text-align: center;">UNACCEPTABLE DAISY-CHAIN GROUND TERMINATION</p> <p>Shield ground leads terminated in a daisy-chain configuration are susceptible to a single-point failure, should one of the links break.</p> <p>NASA-STD-8739.4 [19.6.2.f.2]</p>
	
<p style="text-align: center;">ACCEPTABLE HEAT SHRINKABLE SLEEVING</p> <p>Sleeving shall be sized to provide a tight, smooth finish in the area of maximum diameter. Tubing shall be uniformly shrunk, without cracks, punctures, charred, burns or wrinkles.</p> <p>NASA-STD-8739.4 [9.8.1], [9.11], [19.6.1.e.13]</p>	<p style="text-align: center;">ACCEPTABLE HEAT SHRINK TUBING AS STRESS RELIEF</p> <p>The sleeving covers the termination and extends a minimum of 5 mm (0.20 in.) over the wire insulation. Tubing is fully shrunk, tight and sufficiently rigid to provide stress relief and prevent flexure at the solder termination.</p> <p>NASA-STD-8739.4 [9.9], [Fig. A]</p>

NASA WORKMANSHIP STANDARDS

 <p>NATIONAL AERONAUTICS AND SPACE ADMINISTRATION JOHNSON SPACE CENTER HOUSTON, TEXAS USA 77058</p>	Released: 04.05.2002	Revision:	Revision Date:
	Book: 4	Section: 4.01	Page: 7

**CABLE AND HARNESS
GENERAL REQUIREMENTS (cont.)**

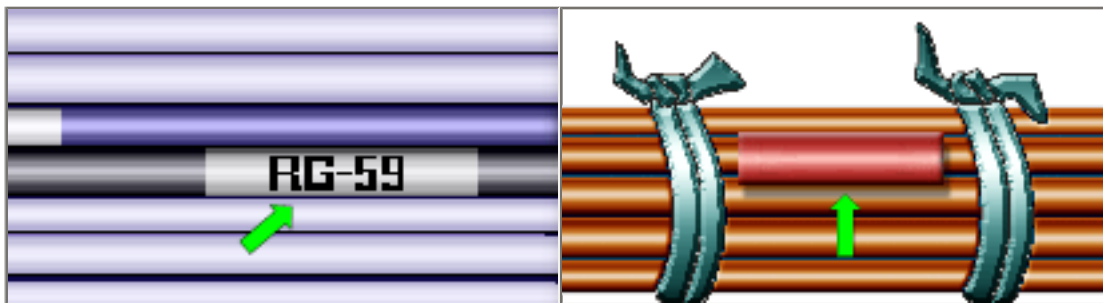

ACCEPTABLE IDENTIFICATION

Each cable/harness shall be identified by a permanent label/markings. Each connector shall be identified by a permanent label/markings affixed directly to the connector body, or to the cable adjacent to the connector.

[NASA-STD-8739.4 \[14.2.1\], \[14.2.2\]](#)

ACCEPTABLE IN-LINE SPLICE

The splice exhibits a smooth profile, proper strain relief and is located in an area of the harness not subjected to flexure.

[Best Workmanship Practice](#)

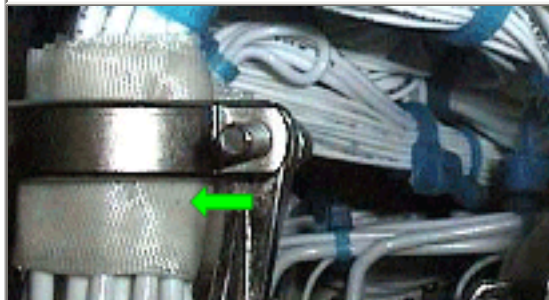

ACCEPTABLE INSULATION WRAP

Non-conductive tape/insulation wrap may be used in applications in which the use of heat-shrinkable tubing is impractical. Tape and wrapping materials shall be installed per engineering documentation.

[Best Workmanship Practice](#)



ACCEPTABLE METAL BRAID SLEEVING

Metal braid sleeving may be installed over harnesses by either direct weave or by use of prewoven tubing. An insulation/separation layer shall be installed between the harness and the metal braid.

[NASA-STD-8739.4 \[9.7\]](#)

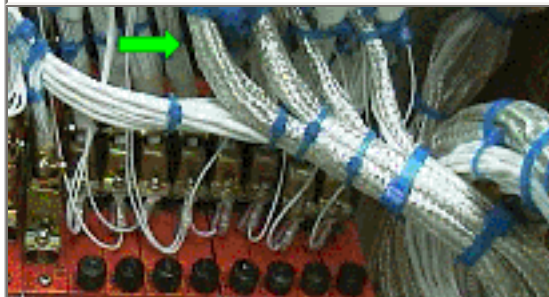

ACCEPTABLE OVERALL HARNESS SHIELDING

An overall braided metallic shield provides mechanical and electrical protection (EMI/RFI) to the harness. Metallic shielding shall exhibit a smooth and tight finish, with a uniform distribution of coverage and no projecting strands.

[NASA-STD-8739.4 \[11.1.3\]](#)

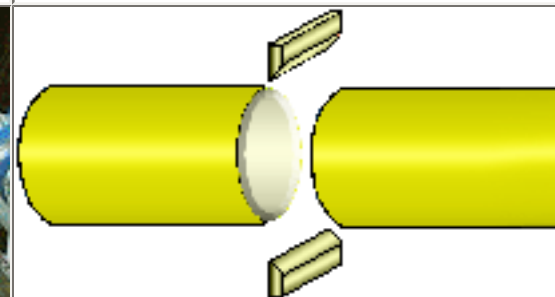

ACCEPTABLE POLYIMIDE/NYLON BRAID SLEEVING HOT KNIFE SEALING

Polyimide or nylon braids (for use on ground support equipment) may have their ends sealed by use of a "hot knife" or similar instrument.

[NASA-STD-8739.4 \[9.3.4\]](#)

NASA WORKMANSHIP STANDARDS



NATIONAL AERONAUTICS AND SPACE ADMINISTRATION
JOHNSON SPACE CENTER
HOUSTON, TEXAS USA 77058

Released:
04.05.2002

Revision:

Revision Date:

Book:
4

Section:
4.01

Page:
8

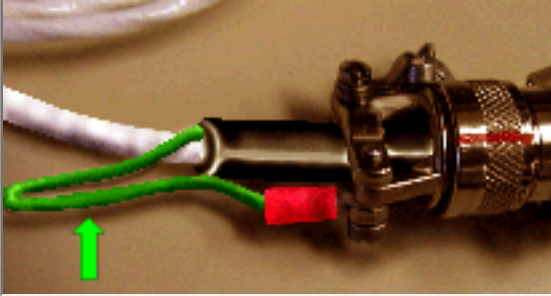
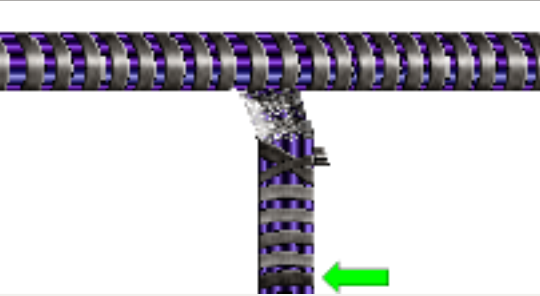
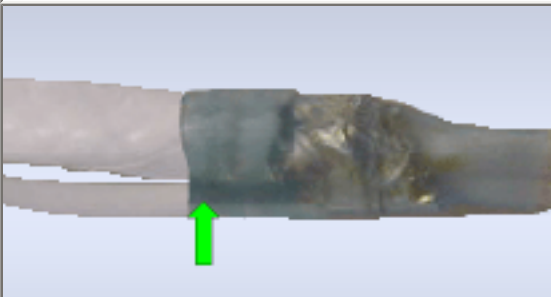
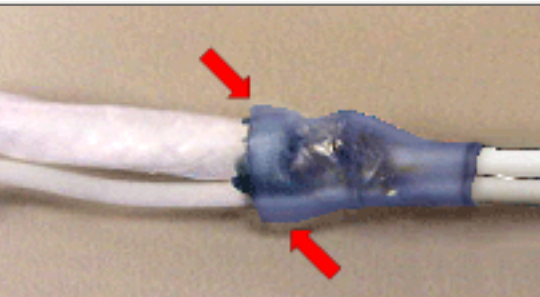
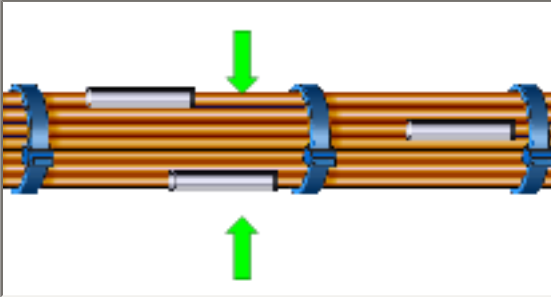
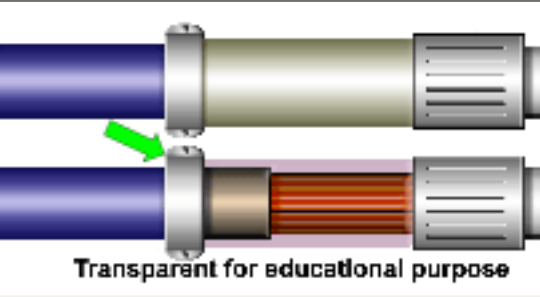
CABLE AND HARNESS GENERAL REQUIREMENTS (cont.)				
				
<p>ACCEPTABLE SHIELD/DRAIN WIRE</p> <p>The shield and drain wire have been properly terminated, per engineering documentation.</p> <p>NASA-STD-8739.4 [19.6.1.f.2]</p>	<p>ACCEPTABLE SPIRAL WRAP SLEEVING</p> <p>Spiral wrap shall be tight, uniformly spaced and shall not overlap. Ends shall be trimmed to eliminate sharp edges.</p> <p><i>Note: Spiral wrap shall not be used on spacecraft or launch vehicles.</i></p> <p>NASA-STD-8739.4 [9.5]</p>			
				
<p>ACCEPTABLE SOLDER SLEEVE TERMINATION</p> <p>The solder sleeve has been properly installed and tightly shrunk. Strain relief is acceptable. Overlaps are of sufficient length to meet minimum electrical spacing. Solder fillet is visible, fully flowed and smooth.</p> <p>NASA-STD-8739.4 [11.4]</p>	<p>UNACCEPTABLE SOLDER SLEEVE TERMINATION</p> <p>The solder sleeve has not been completely shrunk and is improperly positioned, resulting in a poor fit that does not provide a good mechanical grip or seal, and which does not meet minimum overlap requirements.</p> <p>NASA-STD-8739.4 [9.8.1], [9.11]</p>			
	 <p>Transparent for educational purpose</p>			
<p>ACCEPTABLE SPLICE ASSEMBLY PROFILE</p> <p>The location of splices shall be staggered to minimize the increase in profile to the harness. Final assembly profile shall not impact form, fit or function.</p> <p>Best Workmanship Practice</p>	<p>ACCEPTABLE STRAIN RELIEF</p> <p>The cable (shield/unshielded) should be dressed to ensure that the strain relief mechanism transfers structural stresses from the connector to the cable sheath (or strength member) rather than to the individual conductors.</p> <p>Best Workmanship Practice</p>			
NASA WORKMANSHIP STANDARDS				
	<table border="1"> <tr> <td style="padding: 5px;">Released: 04.05.2002</td> <td style="padding: 5px;">Revision:</td> <td style="padding: 5px;">Revision Date:</td> </tr> </table>	Released: 04.05.2002	Revision:	Revision Date:
Released: 04.05.2002	Revision:	Revision Date:		



NATIONAL AERONAUTICS AND SPACE ADMINISTRATION
 JOHNSON SPACE CENTER
 HOUSTON, TEXAS USA 77058

Book:
4

Section:
4.01

Page:
9

CABLE AND HARNESS
 GENERAL REQUIREMENTS (cont.)

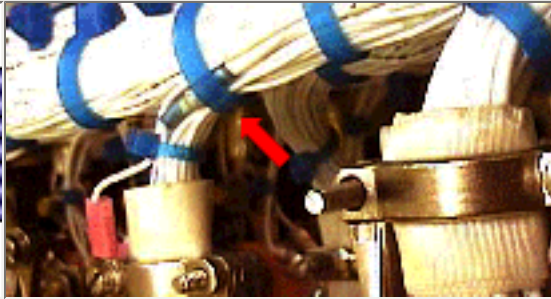
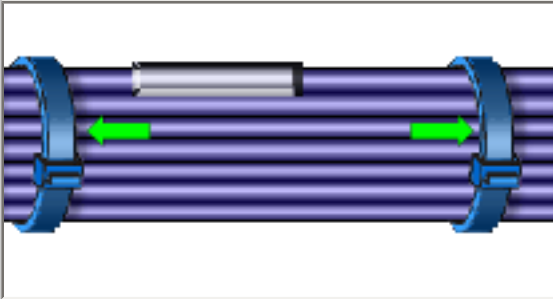

ACCEPTABLE
 SPLICE/SOLDER SLEEVE RESTRAINT

Cable ties/lacing shall be installed at both ends of a splice or solder sleeve, but placement shall not violate stress relief requirements.

[Best Workmanship Practice](#)

UNACCEPTABLE
 SPLICE/SOLDER SLEEVE RESTRAINT

Cable ties/lacing shall not be installed across the splice/ solder sleeve body, unless sufficient protection is provided to prevent compression damage to the termination and/or to the insulation of adjacent conductors.

[Best Workmanship Practice](#)

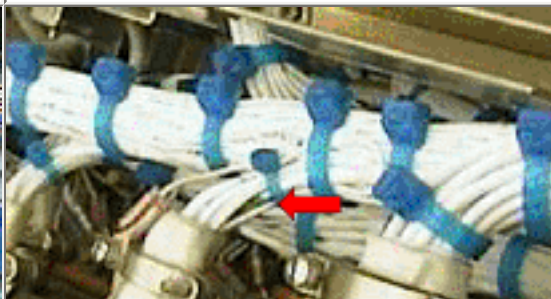
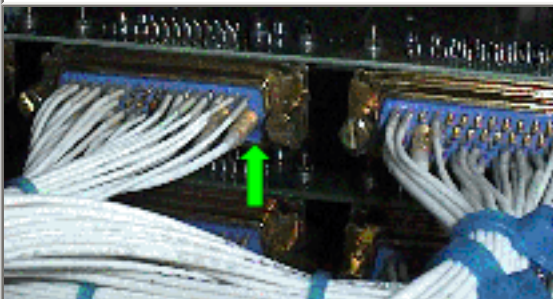

ACCEPTABLE
 STRESS RELIEF

Wires exiting from the connector shall be stress relieved.

[NASA-STD-8739.4 \[7.3.22\]](#)

UNACCEPTABLE
 INSUFFICIENT STRESS RELIEF

The placement of cable ties/straps shall not negate strain relief in cables or harnesses.

[Best Workmanship Practice](#)

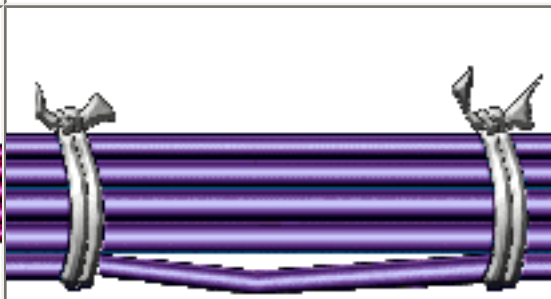
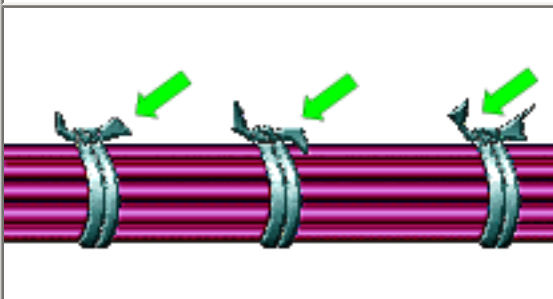

<p>ACCEPTABLE TIE/WRAP SPACING</p> <p>Ties are neat, tight and properly spaced (relative to harness diameter) to maintain the wiring in a tight, neat bundle.</p> <p>NASA-STD-8739.4 [9.2], [19.6.1.e.5]</p>	<p>UNACCEPTABLE INCORRECT TIE SPACING</p> <p>Cable ties/wraps have not been properly spaced relative to bundle/harness diameter.</p> <p>NASA-STD-8739.4 [19.6.2.d.7]</p>
---	---

NASA WORKMANSHIP STANDARDS			
 <p>NATIONAL AERONAUTICS AND SPACE ADMINISTRATION JOHNSON SPACE CENTER HOUSTON, TEXAS USA 77058</p>	Released: 04.05.2002	Revision:	Revision Date:
	Book: 4	Section: 4.01	Page: 10

**CABLE AND HARNESS
GENERAL REQUIREMENTS (cont.)**

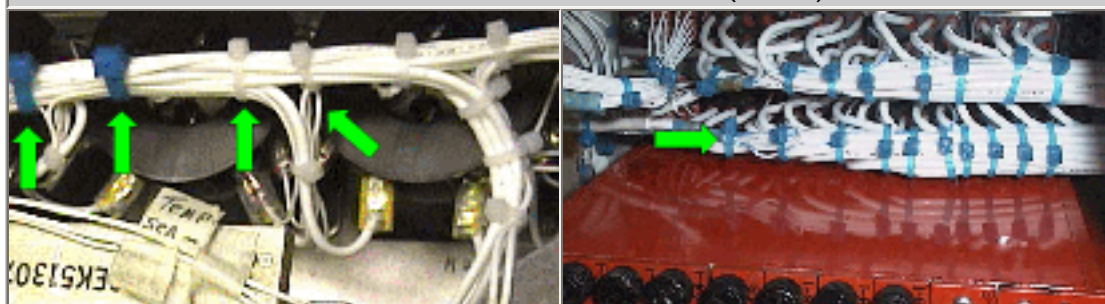

<p>ACCEPTABLE TIE/WRAP SPACING AT BREAKOUT</p> <p>Lacing or tie wraps have been placed on both sides of the harness breakouts. Ties are neat and tight.</p> <p>NASA-STD-8739.4 [9.6]</p>	<p>ACCEPTABLE UNIFORM CONDUCTOR TENSION</p> <p>The conductors exhibit uniform tension throughout the length of the harness. No bunching, bowing, looping, kinks, etc.</p> <p>NASA-STD-8739.4 [19.6.1.e.3]</p>
---	--

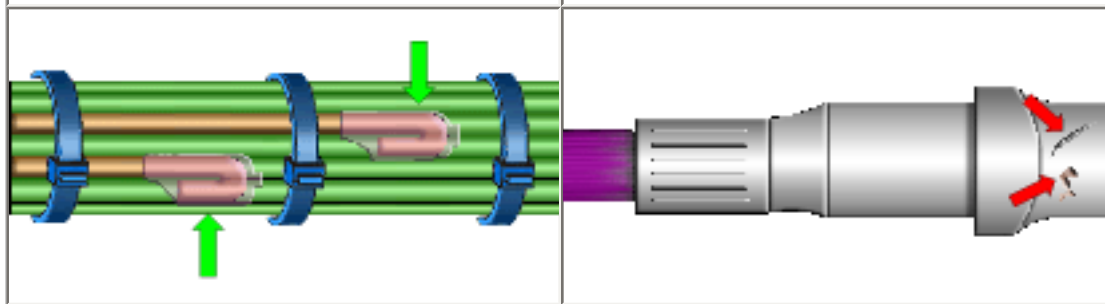

<p>ACCEPTABLE UNUSED/SPARE CONDUCTORS</p> <p>Unused or spare conductors shall be terminated by folding the unstripped end back on itself and then sealed with insulation sleeving or wrap. Conductor ends shall be secured to prevent unwanted movement, protrusion or snagging.</p> <p>NASA-STD-8739.4 [19.6.1.e.19]</p>	<p>UNACCEPTABLE DAMAGE CONNECTOR</p> <p>Damage to the connector (i.e.: cuts, gouges, cracks, deformed features, bent pins, exposed base metal, etc.).</p> <p>NASA-STD-8739.4 [19.6.1.e.1]</p>
--	--

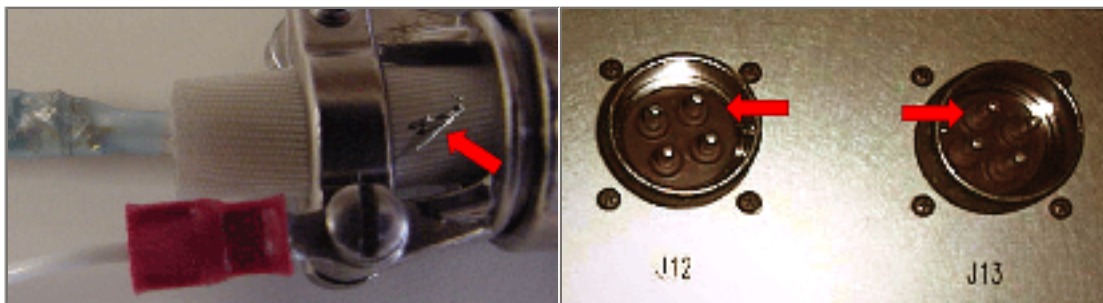

**UNACCEPTABLE
DAMAGE
INSULATION**

Damage to the cable jacket, ribbon or conductor insulation (i.e.: cuts, pinching, nicks, scrapes, crazing, crushing, cold flow, exposed conductors, punctures, thinning or burns).

[NASA-STD-8739.4 \[19.6.2.e.9\]](#)

**UNACCEPTABLE
EXPOSED POWER CONTACTS**

Active signal/live voltages shall be confined to connectors with sockets to preclude the exposure of voltage points when the connector is disconnected.

[NASA-STD-8739.4 \[7.3.18\]](#)

NASA WORKMANSHIP STANDARDS



**NATIONAL AERONAUTICS AND
SPACE ADMINISTRATION**
**JOHNSON SPACE CENTER
HOUSTON, TEXAS USA 77058**

Released:
04.05.2002

Revision:

Revision Date:

Book:
4

Section:
4.01

Page:
11

**CABLE AND HARNESS
GENERAL REQUIREMENTS (cont.)**

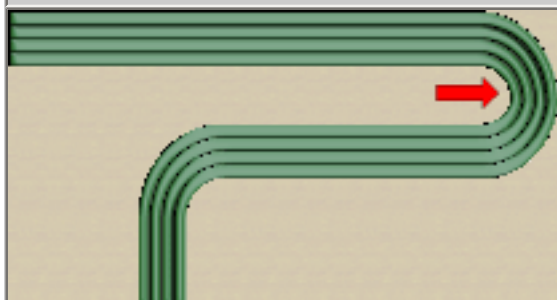

**UNACCEPTABLE
IMPROPER BEND RADIUS**

The harness exhibits a bend radius that is less than the minimum recommended for the conductor type(s) used and overall harness diameter.

[NASA-STD-8739.4 \[7.3.21\]](#)

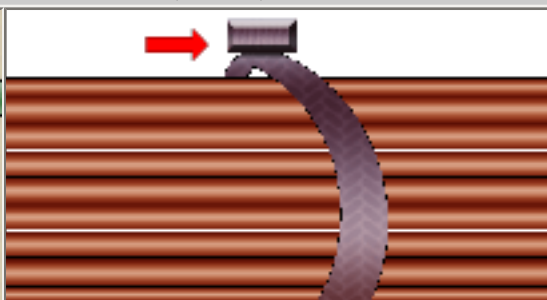



**UNACCEPTABLE
IMPROPER CABLE TIE/WRAP TENSION**

Cable tie/wrap tension is too loose, allowing lateral movement along the cable bundle under normal handling.

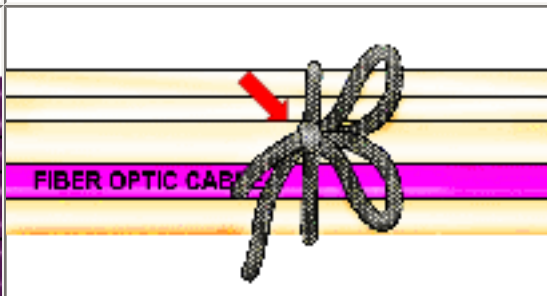
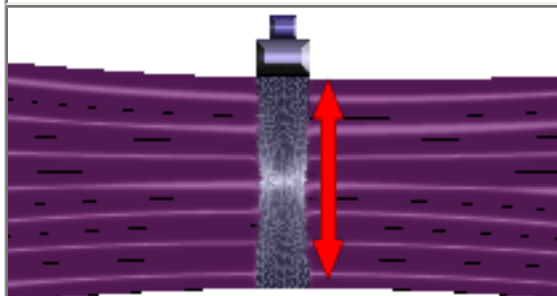
[NASA-STD-8739.4 \[19.6.2.d.4\]](#)

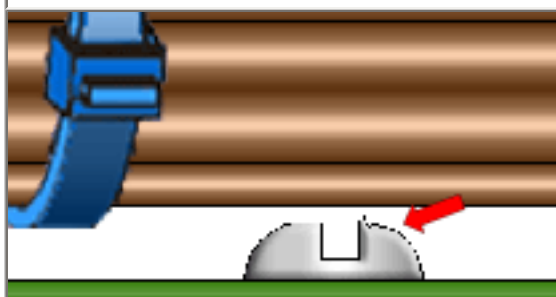
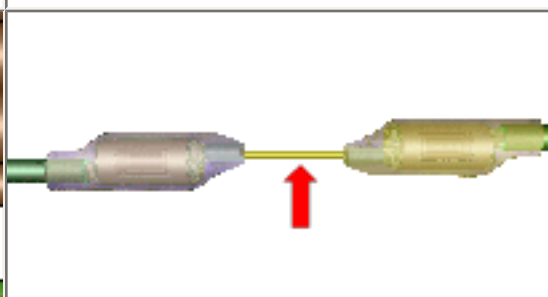

<p style="text-align: center;">UNACCEPTABLE IMPROPER CABLE TIE/WRAP TENSION</p> <p>Cable tie/wrap tension is too high, resulting in deformation and pinching of the wire insulation.</p> <p>NASA-STD-8739.4 [19.6.2.d.3]</p>	<p style="text-align: center;">UNACCEPTABLE IMPROPER LACING KNOT</p> <p>The cable lacing has been secured with a bow-knot, rather than a square/non-slip knot. This tie may eventually loosen.</p> <p>NASA-STD-8739.4 [19.6.2.d.4]</p>
	
<p style="text-align: center;">UNACCEPTABLE IMPROPER ROUTING</p> <p>Cables and harnesses shall be routed so that they are protected from abrasion, cold flow, cut through, vibration, chafing, flexing and sharp edges.</p> <p>NASA-STD-8739.4 [7.3.14]</p>	<p style="text-align: center;">UNACCEPTABLE IMPROPER SPLICE GAUGE/SIZE</p> <p>Replacement conductors shall be of the same voltage and current rating as the original conductor.</p> <p>Best Workmanship Practice</p>

NASA WORKMANSHIP STANDARDS			
 <p>NATIONAL AERONAUTICS AND SPACE ADMINISTRATION JOHNSON SPACE CENTER HOUSTON, TEXAS USA 77058</p>	Released: 04.05.2002	Revision:	Revision Date:
	Book: 4	Section: 4.01	Page: 12

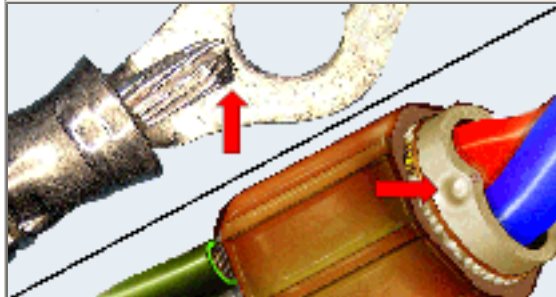
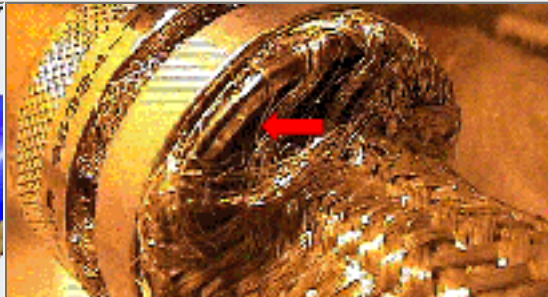
CABLE AND HARNESS GENERAL REQUIREMENTS (cont.)	
	
<p style="text-align: center;">UNACCEPTABLE IMPROPER TERMINATION</p> <p>Solder and/or crimped terminations that do not meet the requirements of NASA-STD-8739.3 and/or NASA-STD-8739.4 shall be cause for rejection.</p> <p>NASA-STD-8739.4 [13.1]</p>	<p style="text-align: center;">UNACCEPTABLE INCOMPLETE COVERAGE OF METAL BRAID</p> <p>Metal braid sleeving shall exhibit uniform coverage, to provide electrical and mechanical protection to the underlying harness.</p> <p>NASA-STD-8739.4 [19.6.2.b.8], [19.6.2.e.5]</p>

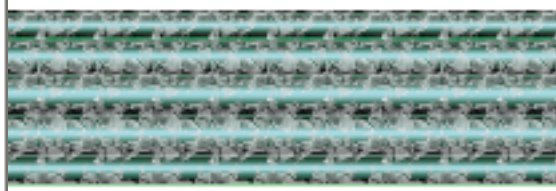
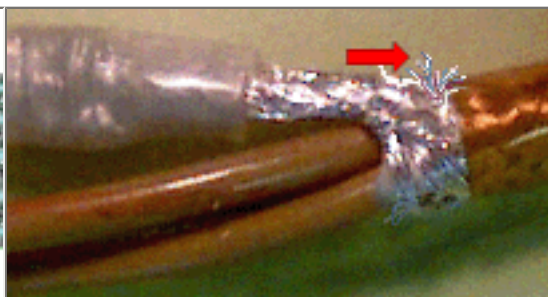
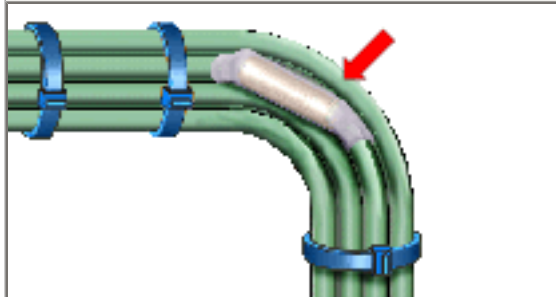
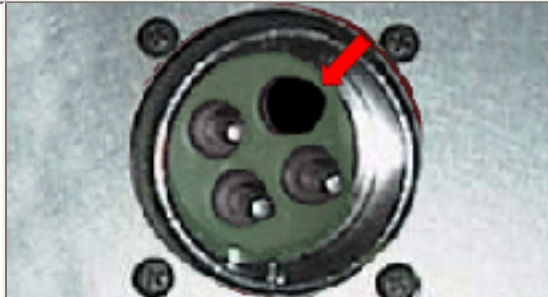
	
<p style="text-align: center;">UNACCEPTABLE INCORRECT LACING MATERIAL</p> <p>Waxed lacing shall not be used for spaceflight applications. NASA-STD-8739.4 [19.6.2.d.2]</p>	<p style="text-align: center;">UNACCEPTABLE PROJECTING SHIELD STRANDS</p> <p>The shield strands have been improperly dressed, resulting in projecting strands that may result in an electrical short or sharp object (puncture/snag) concern. Best Workmanship Practice</p>
	
<p style="text-align: center;">UNACCEPTABLE SPLICES IN FLEXURE ZONE</p> <p>Splices shall not be installed in areas where the harness is designed to flex. Best Workmanship Practice</p>	<p style="text-align: center;">UNACCEPTABLE UNSEALED ENVIRONMENTAL CONNECTOR</p> <p>Sealing plugs or unused pins shall be installed in all unwired/unused holes to retain the environmental rating of the connector. NASA-STD-8739.4 [7.3.19]</p>

NASA WORKMANSHIP STANDARDS

 <p>NATIONAL AERONAUTICS AND SPACE ADMINISTRATION JOHNSON SPACE CENTER HOUSTON, TEXAS USA 77058</p>	Released: 04.05.2002	Revision:	Revision Date:
	Book: 4	Section: 4.01	Page: 13



[Need a printed copy?](#)
(May take a while to load.)
Requires Adobe Reader.



[Need Adobe Reader?](#)
[Click here to download.](#)



[Questions? Suggestions?](#)

CABLE AND HARNESS
DISCRETE CONDUCTOR HARNESES

DISCRETE CONDUCTOR HARNESES

Discrete conductor harnesses are built to print for specific applications, and are constructed of one or more individually insulated wires, cables or fiber optics; with or without an overall helical twist; with or without an overall covering, jacket or metallic braid; with or without breakouts; assembled with two or more electrical termination devices; and engineered as a unit that can be assembled and handled as a single component.

See Section 4.01 "Cable and Harness, General Requirements", for common accept/reject criteria.

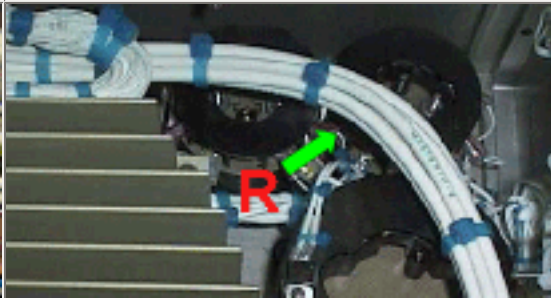
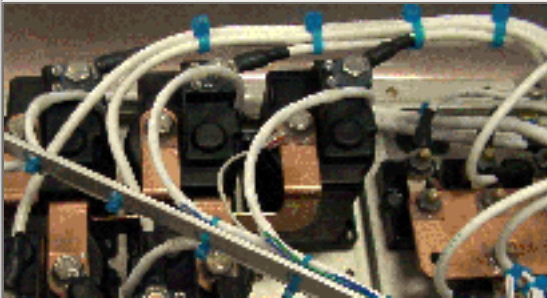
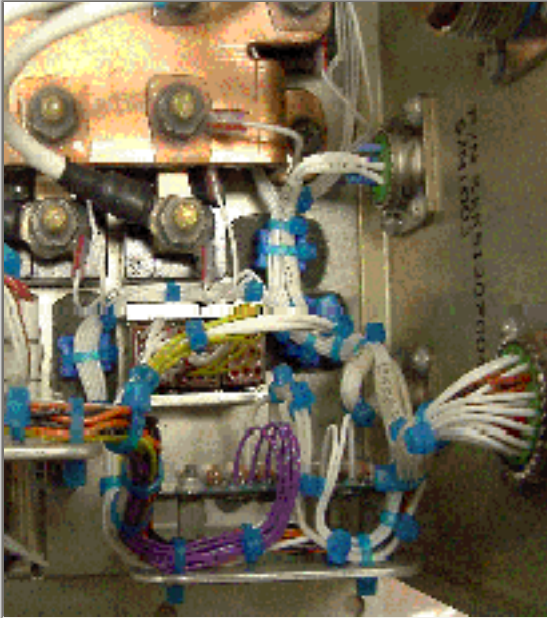

PREFERRED
GENERAL HARNESES

Harness and connectors are clean, damage-free and free of contamination and/or corrosion. Dimensions, layout and identification meet design requirements.

[NASA-STD-8739.4 \[19.6.1.e\]](#)

MANDATORY
BEND RADIUS

Cables and harnesses shall not be subjected to bending forces resulting in radii less than the minimum specified for the most sensitive component (i.e.: coaxial, fiber, etc.) in the assembly.

[Best Workmanship Practice](#)

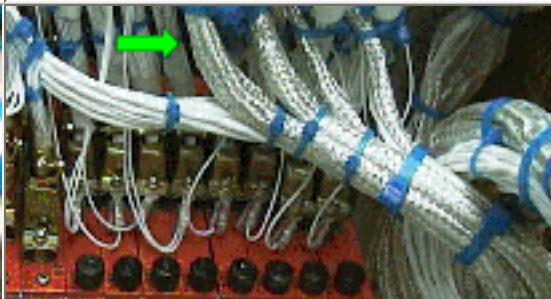
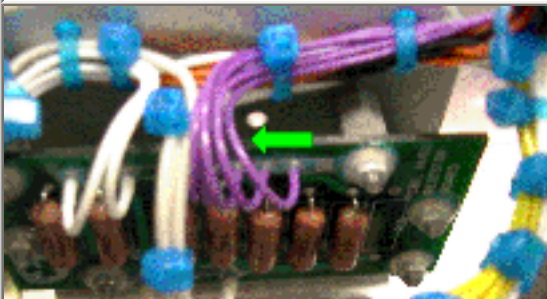

ACCEPTABLE
CONDUCTOR DRESS

All wires are dressed with even bends and sufficient strain relief. Conductor crossover is minimized.

[NASA-STD-8739.4 \[19.6.1.e\]](#)

ACCEPTABLE
OVERALL SHIELDING

An overall braided metallic shield provides mechanical and electrical protection (EMI/RFI) to the harness. Metallic shielding shall exhibit a smooth and tight finish, with a uniform distribution of coverage and no projecting strands.

[NASA-STD-8739.4 \[11.1.3\]](#)

NASA WORKMANSHIP STANDARDS

Released:
04.05.2002

Revision:

Revision Date:



NATIONAL AERONAUTICS AND
SPACE ADMINISTRATION
JOHNSON SPACE CENTER
HOUSTON, TEXAS USA 77058

Book:
4

Section:
4.02

Page:
1

CABLE AND HARNESS
DISCRETE CONDUCTOR HARNESSES (cont.)

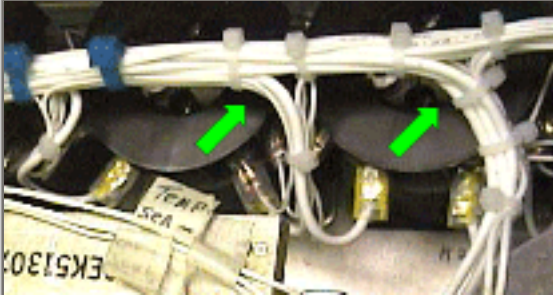

ACCEPTABLE
TIE/WRAP SPACING AT BREAKOUT

Lacing or tie wraps have been placed on both sides of the harness breakouts. Ties are neat and tight.

[NASA-STD-8739.4 \[9.6\]](#)

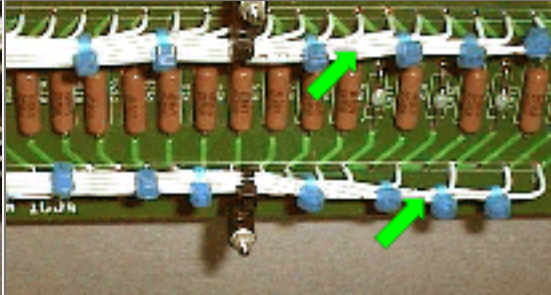

ACCEPTABLE
UNIFORM CONDUCTOR TENSION

The conductors exhibit uniform tension throughout the length of the harness. No bunching, bowing, looping, kinks, etc.

[NASA-STD-8739.4 \[19.6.1.e.3\]](#)

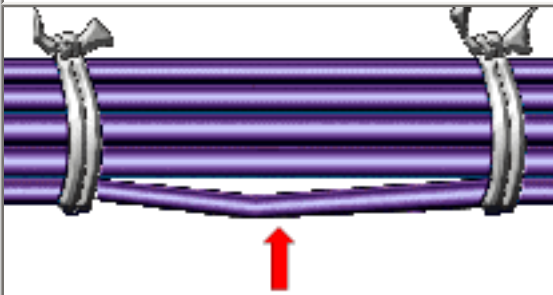

UNACCEPTABLE
INCORRECT TIE SPACING

Cable ties/wraps have not been properly spaced relative to bundle/harness diameter.

[NASA-STD-8739.4 \[19.6.2.d.7\]](#)

 NATIONAL AERONAUTICS AND SPACE ADMINISTRATION JOHNSON SPACE CENTER HOUSTON, TEXAS USA 77058	Released: 04.05.2002	Revision:	Revision Date:
	Book: 4	Section: 4.02	Page: 2



[Need a printed copy?](#)
(May take a while to load.)
Requires Adobe Reader.



[Need Adobe Reader?](#)
[Click here to download.](#)



[Questions? Suggestions?](#)

CABLE AND HARNESS
MULTI-CONDUCTOR

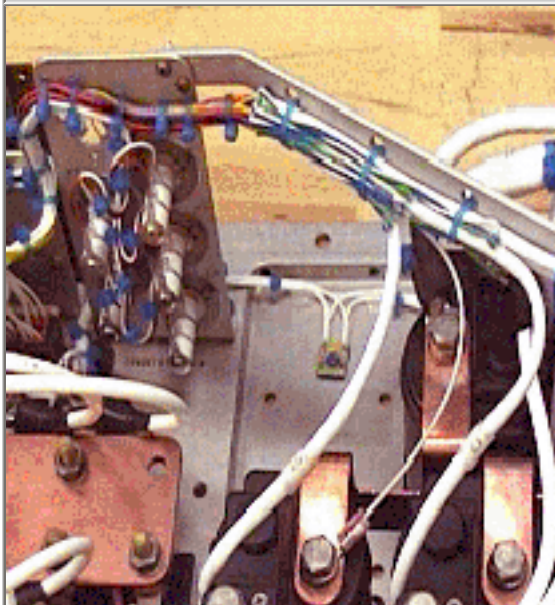

MULTI-CONDUCTOR

Multi-conductor cable is an engineered wiring product, typically constructed of two (2) or more individually insulated conductors, bound together by an overall insulation jacket (unshielded); or, bound and wrapped with an overall metallic covering (braid or foil), and covered by an overall insulation jacket (shielded).

Multiconductor cable is used primarily for the transmission of control and/or data signals.

See Section 4.01 "Cable and Harness, General Requirements", for common accept/reject criteria.

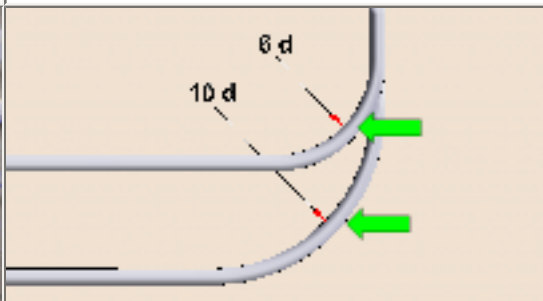
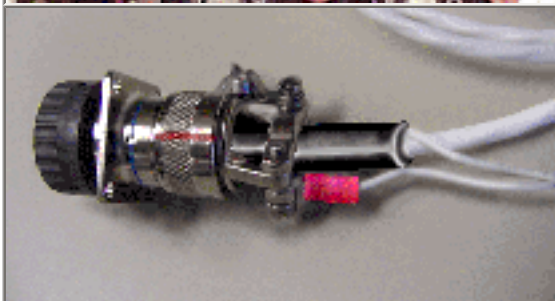

GENERAL REQUIREMENTS

Cable and connectors are clean, damage-free and free of contamination and/or corrosion. Shields are terminated per engineering requirements. Dimensions, layout and identification meet design requirements.

[NASA-STD-8739.4 \[19.6.1\]](#)

PREFERRED
BEND RADIUS
(EXCLUDING KAPTON®)

Cables insulated with materials other than Kapton® shall not be bent less than six (6) outer diameters. The recommended long-term bend radius is ten (10) diameters.

[NASA-STD-8739.4 \[7.3.21\]](#)

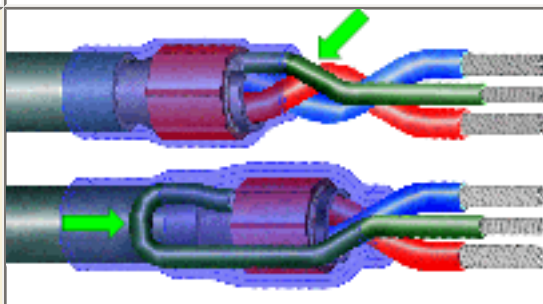
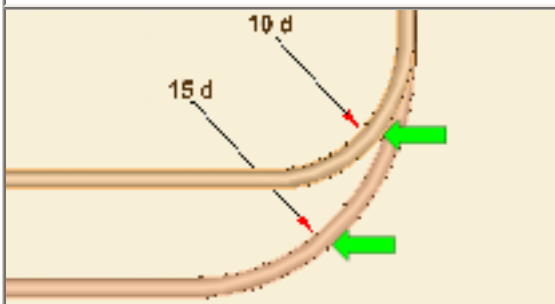

PREFERRED
BEND RADIUS
(KAPTON®)

Kapton® insulated cables shall not be bent less than ten (10) outer diameters. The recommended long-term bend radius is fifteen (15) diameters.

[NASA-STD-8739.4 \[7.3.21\]](#)

ACCEPTABLE
SHIELD TERMINATION - CRIMP SLEEVE

Heat shrink sections are properly installed, tightly shrunk and the termination is visible. Overlaps meet minimum electrical spacing. Ground wire exhibits proper bend radius and strain relief.

[NASA-STD-8739.4 \[7.3.22\], \[19.6.1\]](#)

NASA WORKMANSHIP STANDARDS

Released:
04.05.2002

Revision:

Revision Date:



CABLE AND HARNESS MULTI-CONDUCTOR (cont.)

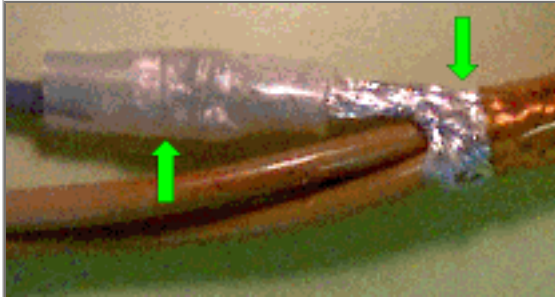

ACCEPTABLE SHIELD TERMINATION - LASH SPLICE INTERIM ASSEMBLY

The termination exhibits a fully wetted solder termination. Shield braid is smooth and evenly dressed with no sharp edges or projections. Shrink tubing properly installed and tight.

[Best Workmanship Practice](#)



ACCEPTABLE SOLDER SLEEVE TERMINATION

The solder sleeve has been properly installed and tightly shrunk. Strain relief is acceptable. Overlaps are of sufficient length to meet minimum electrical spacing. Solder fillet is visible, fully flowed and smooth.

[NASA-STD-8739.4 \[11.4\]](#)

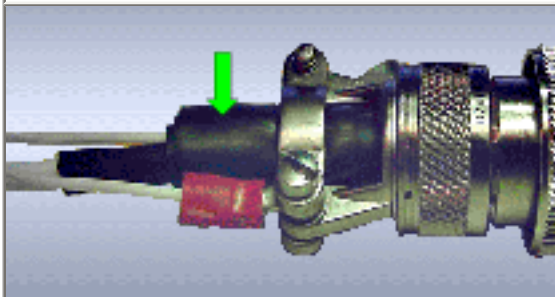

ACCEPTABLE STRAIN RELIEF

The cable (shielded/unshielded) should be dressed to ensure that the strain relief mechanism transfers structural stresses from the connector to the cable sheath (or strength member) rather than to the individual conductors.

[Best Workmanship Practice](#)

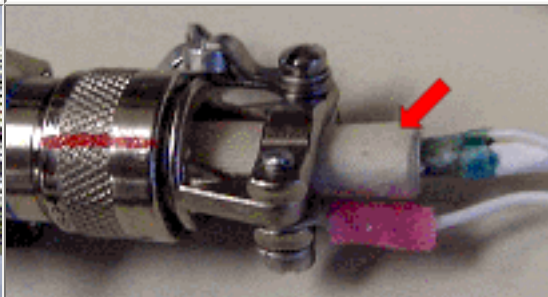

UNACCEPTABLE IMPROPER STRAIN RELIEF

The cable has been dressed in a manner that results in the possible transfer of stress from the connector to the individual conductors, rather than to the cable sheath or stress member.

[Best Workmanship Practice](#)

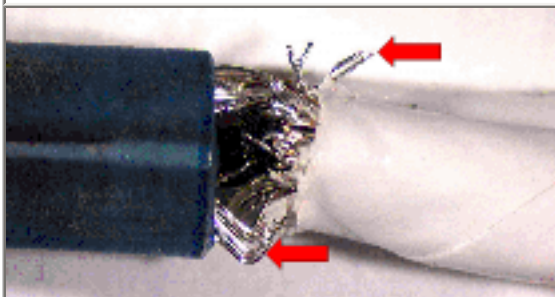

UNACCEPTABLE
PROJECTING SHIELD STRANDS

The shield strands have been improperly dressed, resulting in projecting strands that may result in an electrical short or sharp object (puncture/snag) concern.

[Best Workmanship Practice](#)

NASA WORKMANSHIP STANDARDS

 NATIONAL AERONAUTICS AND SPACE ADMINISTRATION JOHNSON SPACE CENTER HOUSTON, TEXAS USA 77058	Released: 04.05.2002	Revision:	Revision Date:
	Book: 4	Section: 4.03	Page: 2



[Need a printed copy?](#)
(May take a while to load.)
Requires Adobe Reader.



[Need Adobe Reader?](#)
[Click here to download.](#)

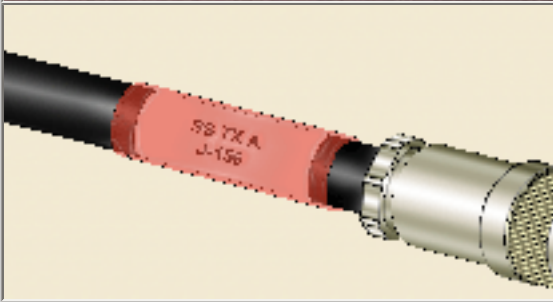
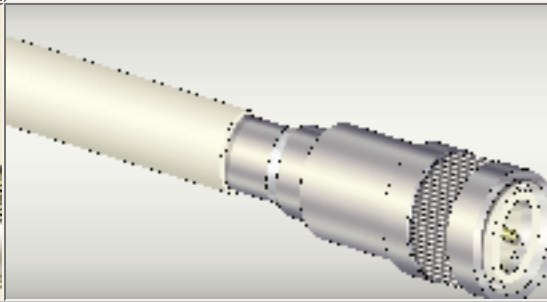
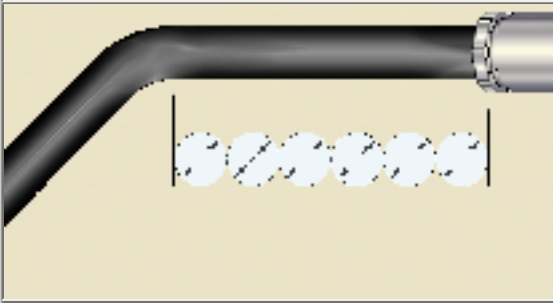
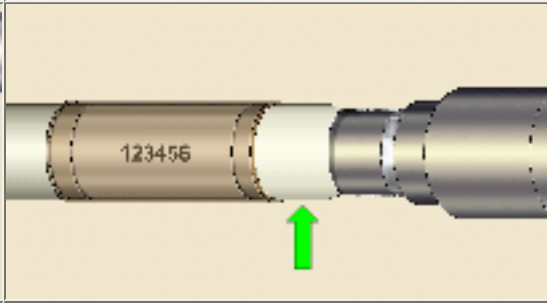

[Questions? Suggestions?](#)

CABLE AND HARNESS COAXIAL			
	<p style="text-align: center;"><u>COAXIAL</u></p> <p>Coaxial is an engineered cable product, typically supplied in the form of a central conductor insulated by a dielectric material, held in concentric orientation to a conductive tubing or sheathing that serves both as an EMI/RFI shield and as a return circuit path.</p> <p>Coaxial systems are available in different technologies, ranging from flexible, insulated cable; to semi-rigid and rigid metallic sheathed.</p> <p>The selection of a particular coaxial cable technology involves the careful consideration of the specific electrical, mechanical and environmental requirements of the project.</p>		
			
<p style="text-align: center;">PREFERRED FLEXIBLE CABLE</p> <p>Cable dimensions and layout meet design requirements, with smooth bends and sufficient stress relief. Connector backshell is properly assembled and torqued. Cable insulation jacket is smooth and continuous, shield properly secured.</p> <p>NASA-STD-8739.4 [19.6.1.f]</p>	<p style="text-align: center;">PREFERRED SEMI-RIGID/RIGID CABLE</p> <p>Completed cable meets dimensional and layout requirements, with smooth surface, bends, uniform diameter and sufficient stress relief. Connectors exhibit properly formed solder/weld fillets and are contamination/corrosion-free.</p> <p>NASA-STD-8739.4 [19.6.1.f]</p>		
			
<p style="text-align: center;">MANDATORY CABLE TERMINUS ALIGNMENT</p> <p>A minimum straight length of six (6) cable diameters is required at each finished cable end to allow for clearance and strain relief, unless specified otherwise in the engineering documentation.</p> <p>Best Workmanship Practice</p>	<p style="text-align: center;">MANDATORY COATING/FINISH</p> <p>In applications requiring the cable assembly to be coated or painted, the finish shall be applied to the outer sheath only, and shall stop at least 5 mm (0.20 in.) from the back of the connector. The connector shall not be coated or painted.</p> <p>Best Workmanship Practice</p>		
<p>NASA WORKMANSHIP STANDARDS</p>			
	<p>Released: 04.05.2002</p>	<p>Revision:</p>	<p>Revision Date:</p>



CABLE AND HARNESS
 COAXIAL (cont.)

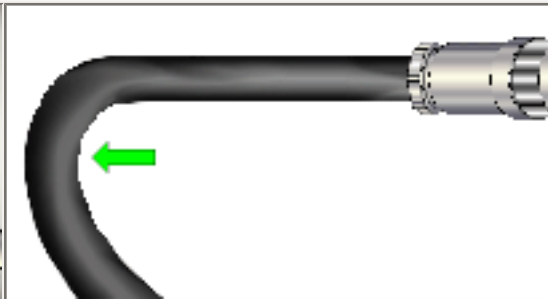
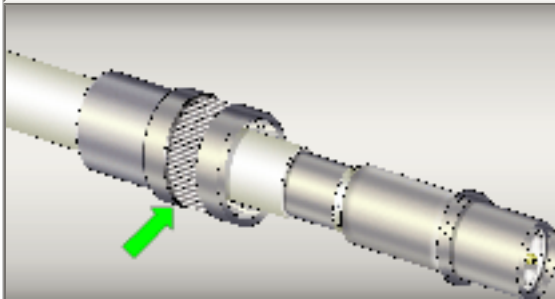

**MANDATORY
 FLOATING NUTS**

Semi-rigid/rigid cable assemblies shall be designed with connectors with retractable (non-captive/floating) coupling nuts, reducing the possibility that the cable assembly will be in a state of tension/torsion during connector mating.

[Best Workmanship Practice](#)

**MANDATORY
 MINIMUM BEND RADIUS**

Coaxial cables shall not be bent below the minimum recommended inside bend radius (6 diameters for flexible, 2 diameters for semi-rigid and rigid).

[Best Workmanship Practice](#)

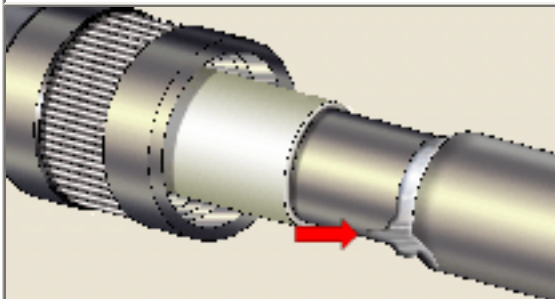

**UNACCEPTABLE
 EXCESS/IMPROPER SOLDER**

The solder termination between the connector and the rigid/semi-rigid cable sheath shall exhibit a fully wetted, concave, smooth and continuous fillet which extends completely around the termination periphery.

[Best Workmanship Practice](#)

**UNACCEPTABLE
 IMPROPER ASSEMBLY
 CENTER CONTACT(S)**

Center contact location/orientation does not meet requirements for proper mating.

[NASA-STD-8739.4 \[19.6.2.f.3\]](#)

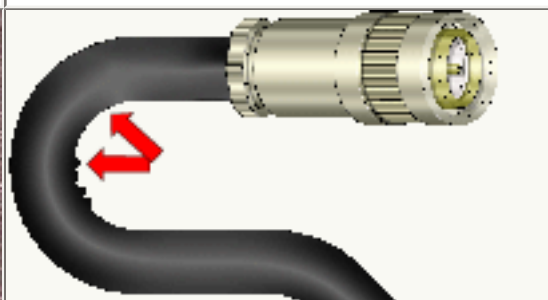

<p>UNACCEPTABLE IMPROPER ASSEMBLY CONNECTOR</p> <p>The connector has not been assembled per the manufacturer's or engineering documentation. The connector body has been crimped by the center pin crimp tool, crushing the dielectric.</p> <p>NASA-STD-8739.4 [19.6.2.f]</p>	<p>UNACCEPTABLE IMPROPER BEND RADIUS</p> <p>The cable has been bent below the minimum radius recommended, resulting in ripples and stretching in the cable sheath and possible cold-flow of the dielectric, resulting in increased attenuation and/or shorting.</p> <p>Best Workmanship Practice</p>
--	---

NASA WORKMANSHIP STANDARDS			
 <p>NATIONAL AERONAUTICS AND SPACE ADMINISTRATION JOHNSON SPACE CENTER HOUSTON, TEXAS USA 77058</p>	Released: 04.05.2002	Revision:	Revision Date:
	Book: 4	Section: 4.04	Page: 2

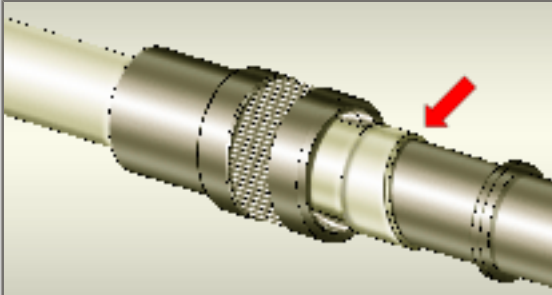
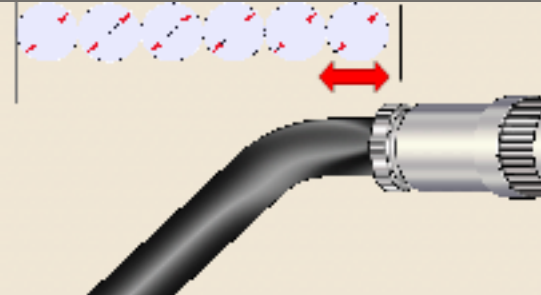
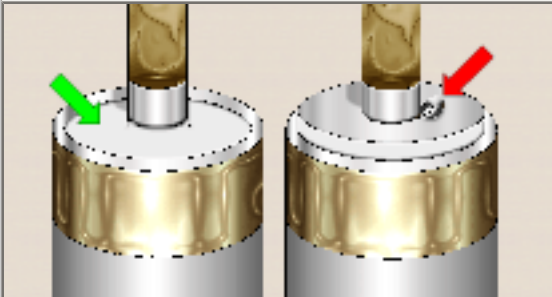
CABLE AND HARNESS COAXIAL (cont.)	
	
<p>UNACCEPTABLE IMPROPER COATING/PAINT</p> <p>The coating has been improperly applied, resulting in interference during assembly and mating.</p> <p>Best Workmanship Practice</p>	<p>UNACCEPTABLE IMPROPER TERMINUS SPACING</p> <p>The termination exhibits an improper minimum straight section length between the connector body and start of nearest bend. This may impede assembly/mating, reduce strain relief or increase cable impedance.</p> <p>Best Workmanship Practice</p>
	
<p>UNACCEPTABLE PROTRUDING DIELECTRIC</p> <p>Care shall be exercised to minimize the protrusion or melting of the dielectric as a result of overheating during tinning and soldering operations.</p> <p>Best Workmanship Practice</p>	

NASA WORKMANSHIP STANDARDS			
 NATIONAL AERONAUTICS AND SPACE ADMINISTRATION JOHNSON SPACE CENTER HOUSTON, TEXAS USA 77058	Released: 04.05.2002	Revision:	Revision Date:
	Book: 4	Section: 4.04	Page: 3





[Need a printed copy?](#)
(May take a while to load.)
Requires Adobe Reader.



[Need Adobe Reader?](#)
[Click here to download.](#)

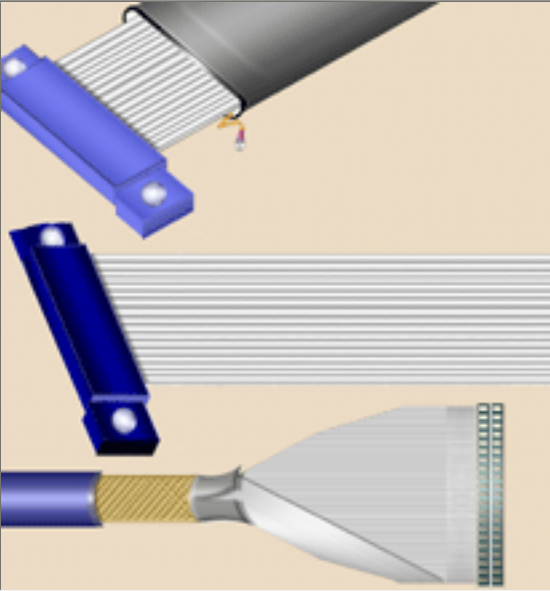
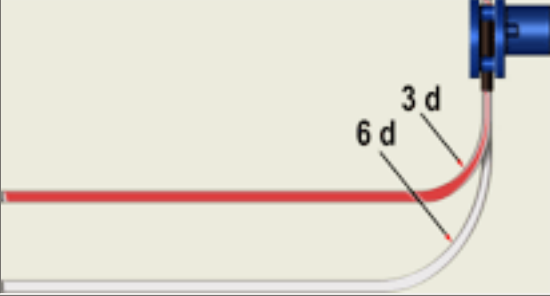

[Questions? Suggestions?](#)

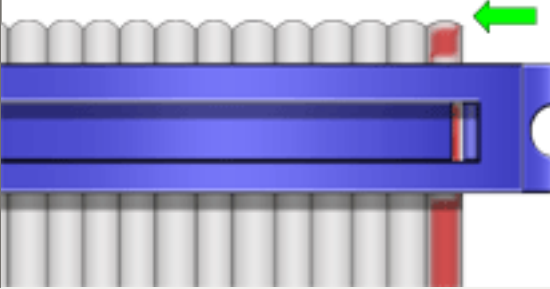
CABLE AND HARNESS FLAT/RIBBON CABLE	
FLAT/RIBBON CABLE	<p>Flat cable is a multi-conductor cable comprised of individually insulated, solid conductors, which are mechanically bonded in a parallel (flat) orientation.</p> <p>Ribbon cable is a multi-conductor cable, comprised of individually insulated, stranded conductors, which are mechanically bonded to each other in a parallel (flat) orientation.</p> <p>Both cable architectures result in a highly flexible, compact and robust cable, allowing mass termination of the conductors to high-density connectors by the insulation displacement contact (IDC) process.</p>
	
GENERAL REQUIREMENTS	PREFERRED BEND RADIUS COAXIAL RIBBON CABLE
<p>The cable assembly meets dimensional, layout and design requirements. Conductors are properly aligned to respective termination pins and properly seated. The assembly exhibits a smooth, flat profile, with no visible damage to the connectors or the insulation.</p>	<p>The bend radius for coaxial ribbon cables shall not be less than six (6) insulated wire diameters short-term, ten (10) diameters long-term.</p> <p>NASA-STD-8739.4 [7.3.21]</p>
	
PREFERRED BEND RADIUS GENERAL	PREFERRED CABLE-END TERMINATIONS
<p>Flat and ribbon cables shall not be creased, folded or bent less than three (3) insulated wire diameters (short-term). The recommended long-term bend radius is ten (10) diameters.</p> <p>NASA-STD-8739.4 [7.3.21]</p>	<p>Cable is properly aligned and oriented in the connector, and the cable end does not protrude in excess of 0.8 mm (0.031 in.) beyond the connector body edge, or violate minimum electrical spacing requirements.</p> <p>Best Workmanship Practice</p>

NASA WORKMANSHIP STANDARDS

Released: 04.05.2002	Revision:	Revision Date:
-------------------------	-----------	----------------



CABLE AND HARNESS
 FLAT/RIBBON CABLE (cont.)

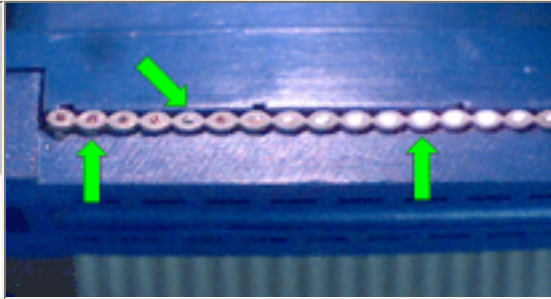
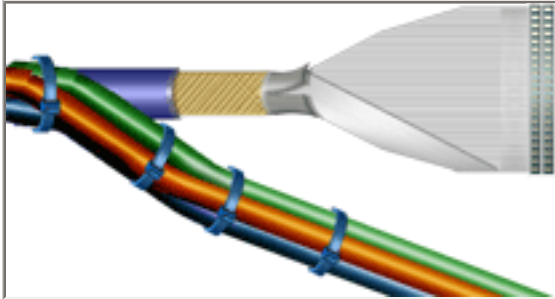

PREFERRED
 DISCRETE WIRE HARNESS DESIGN

Ribbon cables shall not be incorporated into discrete wire harnesses, unless specifically designed for that application. Ribbon cable suitable for harness installation shall be of a round-to-flat, transition/breakout type.

[Best Workmanship Practice](#)

PREFERRED
 ELECTRICAL TERMINATION

The completed connector assembly shall result in the electrical termination of each conductor to the respective termination pin. The termination exhibits alignment to the connector fiducials (small notches/marks) and grooves.

[Best Workmanship Practice](#)

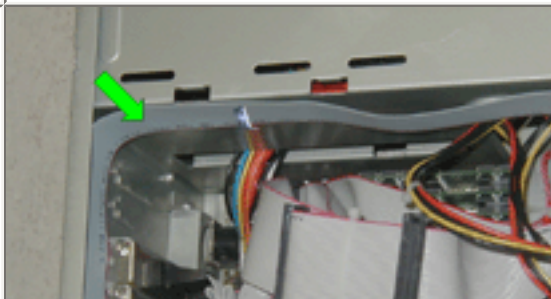
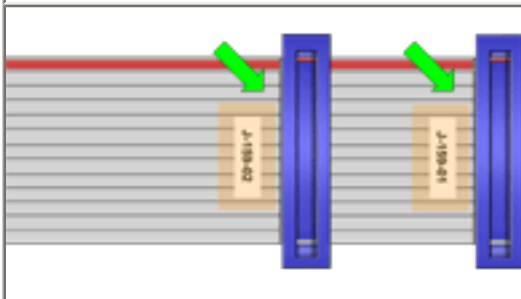

PREFERRED
 INLINE TERMINATIONS

Inline terminations shall be properly oriented and completed only in locations along the cable designed for such terminations, and where sufficient strain relief is available.

[Best Workmanship Practice](#)

PREFERRED
 ROUTING

Ribbon cables should be routed along flat surfaces (either vertical or horizontal) whenever possible, shall be properly supported and secured by cable clamps, and should not be routed near high electrical noise, heat or vibration sources.

[Best Workmanship Practice](#)

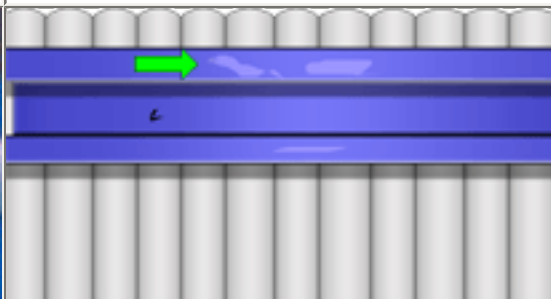
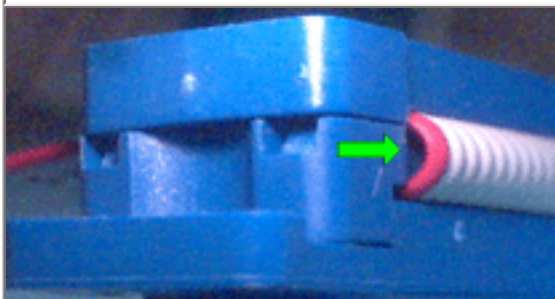

<p style="text-align: center;">ACCEPTABLE BEND RADIUS</p> <p>The cable exhibits proper bend radius at entry and exit of the strain relief clamp device.</p> <p>NASA-STD-8739.4 [7.3.21], [7.3.22]</p>	<p style="text-align: center;">ACCEPTABLE DISCOLORATION/SCUFFING CONNECTOR</p> <p>Slight scuffing or discoloration is acceptable, provided there is no impact to form, fit or function, and there is no exposure of base metal.</p> <p>Best Workmanship Practice</p>
--	---

NASA WORKMANSHIP STANDARDS			
 <p>NATIONAL AERONAUTICS AND SPACE ADMINISTRATION JOHNSON SPACE CENTER HOUSTON, TEXAS USA 77058</p>	<p>Released: 04.05.2002</p>	<p>Revision:</p>	<p>Revision Date:</p>
	<p>Book: 4</p>	<p>Section: 4.05</p>	<p>Page: 2</p>

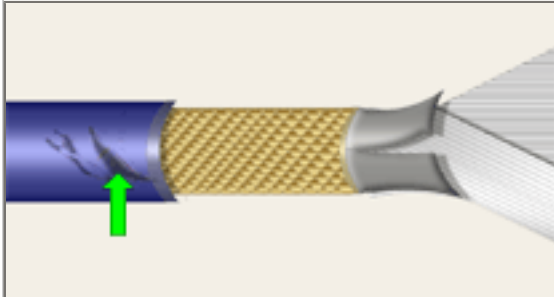
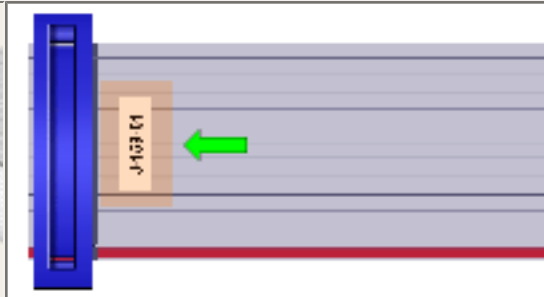
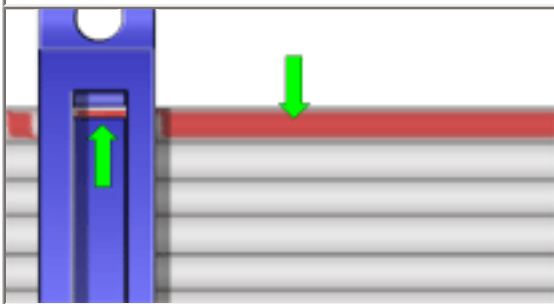
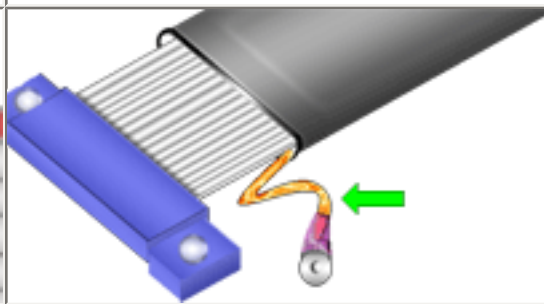

CABLE AND HARNESS GENERAL REQUIREMENTS (cont.)	
	
<p style="text-align: center;">ACCEPTABLE DISCOLORATION/SCUFFING INSULATION</p> <p>The cable does not exhibit evidence of insulation damage, such as cuts, nicks, scrapes, crushing, cold flow or burns. Slight scuffing or discoloration is acceptable.</p> <p>NASA-STD-8739.4 [19.6.2.e.9]</p>	<p style="text-align: center;">ACCEPTABLE IDENTIFICATION</p> <p>Each cable/harness shall be identified by a permanent label/markings. Each connector shall be identified by a permanent label/markings affixed directly to the connector body, or to the cable adjacent to the connector.</p> <p>NASA-STD-8739.4 [14.2.1], [14.2.2]</p>
	
<p style="text-align: center;">ACCEPTABLE POLARIZATION STRIPE/RIDGE</p> <p>The polarization stripe or ridge (if provided) is visible and properly aligned with the connector polarization mark.</p> <p>NASA-STD-8739.4 [19.6.1.e.10]</p>	<p style="text-align: center;">ACCEPTABLE SHIELD/DRAIN WIRE</p> <p>Shield and drain wire are properly terminated, per engineering documentation.</p> <p>NASA-STD-8739.4 [19.6.1.f.2]</p>

<p style="text-align: center;">ACCEPTABLE STRAIN RELIEF</p> <p>Connector-mounted strain relief clips shall be properly positioned and set. NASA-STD-8739.4 [19.6.1.e.23]</p>	<p style="text-align: center;">UNACCEPTABLE DAMAGE CONNECTOR</p> <p>Damage to the connector (i.e.: cuts, gouges, cracks, deformed features, bent pins, exposed base metal, etc.). NASA-STD-8739.4 [19.6.1.e.1]</p>

NASA WORKMANSHIP STANDARDS

<p>NATIONAL AERONAUTICS AND SPACE ADMINISTRATION JOHNSON SPACE CENTER HOUSTON, TEXAS USA 77058</p>	<p>Released: 04.05.2002</p>	<p>Revision:</p>	<p>Revision Date:</p>
	<p>Book: 4</p>	<p>Section: 4.05</p>	<p>Page: 3</p>

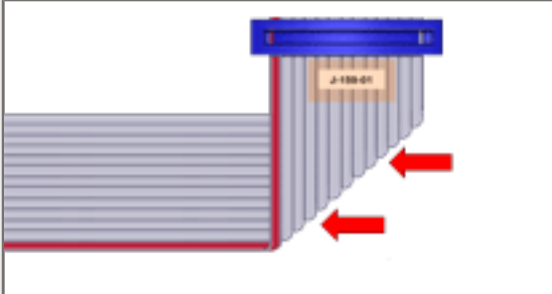
CABLE AND HARNESS FLAT / RIBBON CABLE (cont.)	
<p style="text-align: center;">UNACCEPTABLE DAMAGE INSULATION</p> <p>Damage to the cable jacket, ribbon or conductor insulation (i.e.: cuts, pinching, nicks, scrapes, crazing, crushing, cold flow, exposed conductors, punctures, thinning or burns). NASA-STD-8739.4 [19.6.2.e.9]</p>	<p style="text-align: center;">UNACCEPTABLE EXCESSIVE CONDUCTOR PROTRUSION</p> <p>Cable conductor end(s) protrude in excess of 0.8 mm (0.031 in.) beyond the connector body edge, or violate minimum electrical spacing requirements. Best Workmanship Practice</p>

<p style="text-align: center;">UNACCEPTABLE IMPROPER ALIGNMENT</p> <p>The completed assembly does not exhibit parallel alignment between the connector body and the cable, resulting in improper electrical termination of each conductor to its designated pin.</p> <p>Best Workmanship Practice</p>	<p style="text-align: center;">UNACCEPTABLE IMPROPER ASSEMBLY</p> <p>The cable/connector assembly shall be terminated by the application of a uniform compression across the face of the connector, and shall exhibit parallel alignment between the connector base and compression cap.</p> <p>Best Workmanship Practice</p>
	
<p style="text-align: center;">UNACCEPTABLE IMPROPER BEND RADIUS</p> <p>The cable exhibits creases, folds and/or kinks, which are less than the minimum bend radius, and/or which have visibly stressed the insulation material.</p> <p>Best Workmanship Practice</p>	<p style="text-align: center;">UNACCEPTABLE IMPROPER ROUTING</p> <p>Flat and ribbon cables should not be routed near high electrical noise, heat or vibration sources, or routed so as to not interfere with air ventilation flow patterns.</p> <p>Best Workmanship Practice</p>

NASA WORKMANSHIP STANDARDS				
	<p>NATIONAL AERONAUTICS AND SPACE ADMINISTRATION JOHNSON SPACE CENTER HOUSTON, TEXAS USA 77058</p>	<p>Released: 04.05.2002</p>	<p>Revision:</p>	<p>Revision Date:</p>
		<p>Book: 4</p>	<p>Section: 4.05</p>	<p>Page: 4</p>

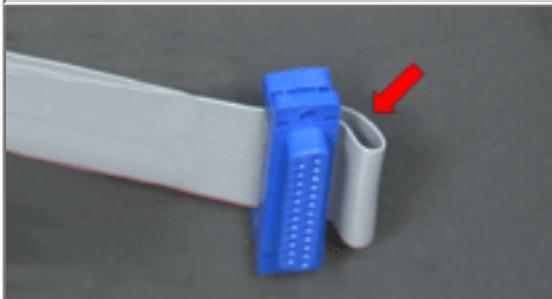
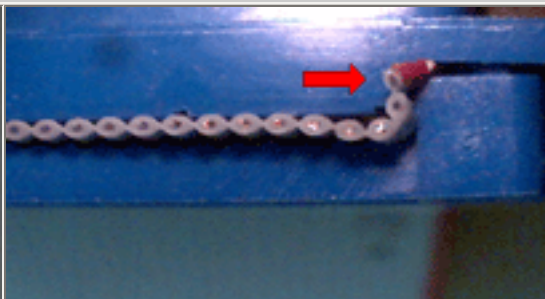
CABLE AND HARNESS FLAT / RIBBON CABLE (cont.)	
	
<p style="text-align: center;">UNACCEPTABLE IMPROPER STRAIN RELIEF</p> <p>Wires exiting from connectors shall be stress relieved. Connector strain relief clamps shall be properly set.</p> <p>NASA-STD-8739.4 [7.3.22]</p>	<p style="text-align: center;">UNACCEPTABLE IMPROPER TERMINATION</p> <p>The completed connector assembly shall result in the electrical termination of each conductor to the respective termination pin. The termination shall exhibit alignment to the connector fiducials (small notches/marks) and grooves.</p> <p>Best Workmanship Practice</p>

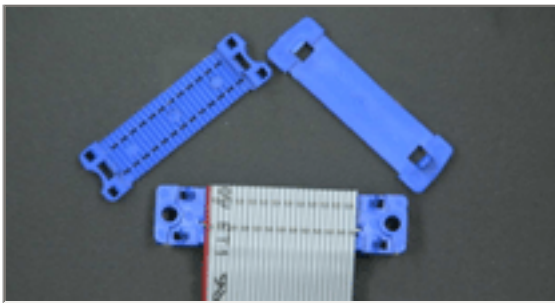

UNACCEPTABLE
MISSING COMPONENTS

Missing connector parts (i.e.: compression cap, strain relief clip, polarized key, etc.) shall be cause for rejection.

[NASA-STD-8739.4 \[19.6.1.e.17\]](#)

NASA WORKMANSHIP STANDARDS			
 <p>NATIONAL AERONAUTICS AND SPACE ADMINISTRATION JOHNSON SPACE CENTER HOUSTON, TEXAS USA 77058</p>	Released: 04.05.2002	Revision:	Revision Date:
	Book: 4	Section: 4.05	Page: 5





[Need a printed copy?](#)
(May take a while to load.)
[Requires Adobe Reader.](#)



[Need Adobe Reader?](#)
[Click here to download.](#)

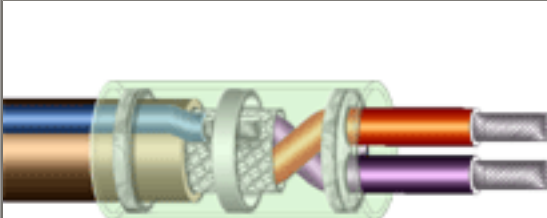
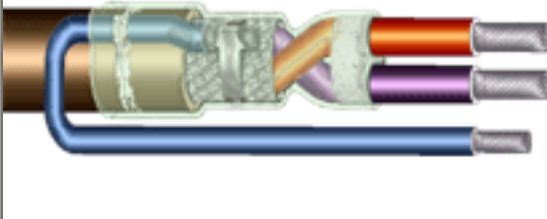
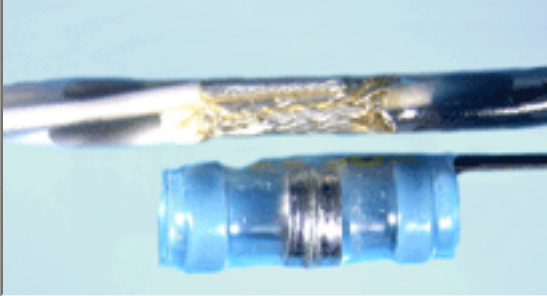
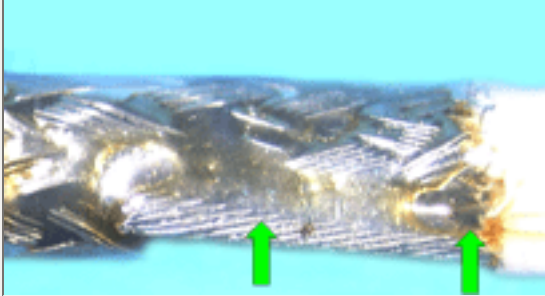
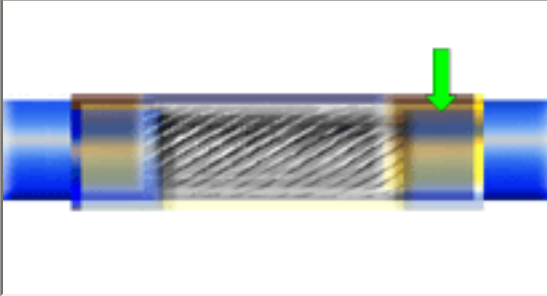
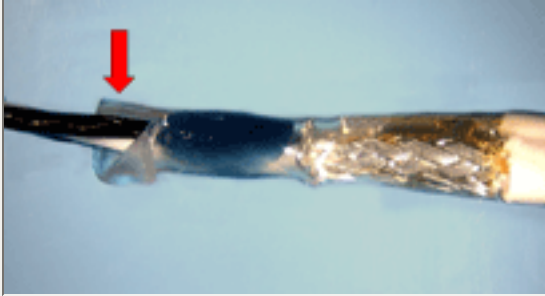

[Questions? Suggestions?](#)

CABLE AND HARNESS SOLDER SLEEVES				
	<p>SOLDER SLEEVES</p> <p>Solder sleeves are primarily used to attach a ground wire (lead) to the shielding braid of a shielded cable by means of a shrinkable tubing assembly having an integral solder preform.</p> <p>Solder sleeves are also used to splice two or more conductors together in a parallel configuration.</p> <p>See Section 4.01 "Cable and Harness, General Requirements", and Section 6.01 "Through-Hole Soldering, General Requirements", for common accept/reject criteria.</p>			
				
				
<p>PREFERRED</p> <p>Solder sleeve has been properly installed and tightly shrunk. Strain relief is acceptable. Overlaps are of sufficient length to meet minimum electrical spacing. Solder fillet is visible, fully flowed and smooth.</p>	<p>ACCEPTABLE CLOSE-UP VIEW</p> <p>The termination exhibits proper solder flow and complete wetting. There is evidence of a complete fillet between the ground wire and the shield. Individual strands are discernable. Minor flux entrapment is acceptable.</p> <p>NASA-STD-8739.4 [19.6.1.b], [19.6.1.g]</p>			
				
<p>ACCEPTABLE DISCOLORATION</p> <p>The solder sleeve may exhibit slight discoloration resulting from the heating process. The sleeve shall not exhibit any damage.</p> <p>NASA-STD-8739.4 [19.6.1.g.3]</p>	<p>UNACCEPTABLE DAMAGED SLEEVE</p> <p>Solder sleeves shall be free of cracks, cuts, crushing, gouges, punctures and charred, melted or burned areas. Slight scuffing or discoloration is acceptable.</p> <p>NASA-STD-8739.4 [19.6.1.g.3], [19.6.2.g.6]</p>			
NASA WORKMANSHIP STANDARDS				
 <p>NATIONAL AERONAUTICS AND SPACE ADMINISTRATION JOHNSON SPACE CENTER HOUSTON, TEXAS USA 77058</p>	<table border="1"> <tr> <td>Released: 04.05.2002</td> <td>Revision:</td> <td>Revision Date:</td> </tr> </table>	Released: 04.05.2002	Revision:	Revision Date:
Released: 04.05.2002	Revision:	Revision Date:		

	Book: 4	Section: 4.06	Page: 1
--	------------	------------------	------------

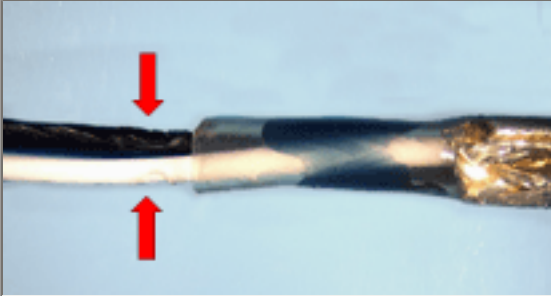
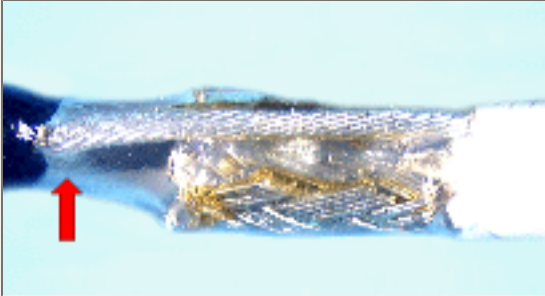
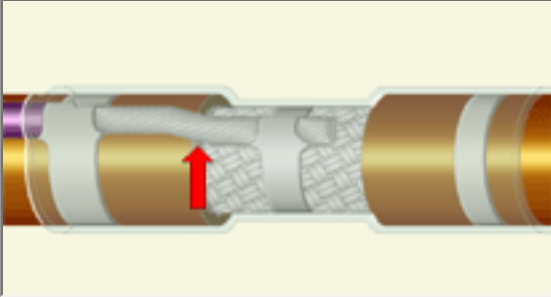
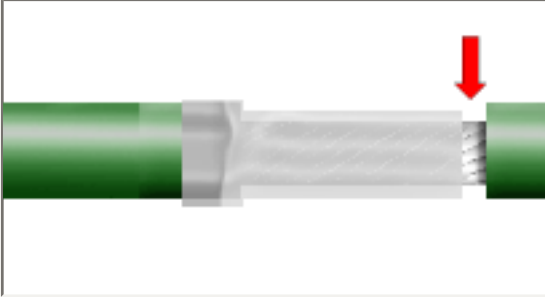
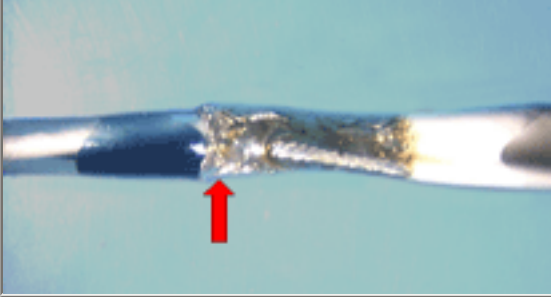
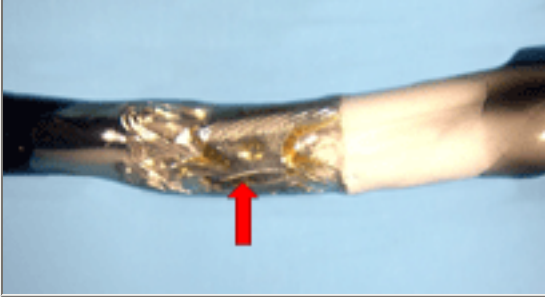
CABLE AND HARNESS SOLDER SLEEVES (cont.)	
	
<p>UNACCEPTABLE DAMAGED WIRE INSULATION</p> <p>Cut, crushed, gouged, damaged, nicked, burned or melted insulation may result in reduced electrical isolation and/or short circuits. Slight scuffing or discoloration is acceptable.</p> <p>NASA-STD-8739.4 [19.6.2.e.9]</p>	<p>UNACCEPTABLE EXCESSIVE CONDUCTOR LENGTH</p> <p>The ground conductor should extend a maximum of flush with the end of the stripped shield section.</p> <p>Best Workmanship Practice</p>
	
<p>UNACCEPTABLE EXCESSIVE INSULATION CLEARANCE</p> <p>The maximum insulation clearance shall be such that the end of the conductor insulation is even with the end of the cable jacket.</p> <p>Best Workmanship Practice</p>	<p>UNACCEPTABLE EXPOSED CONDUCTIVE SURFACES</p> <p>Solder sleeves shall cover all exposed metal in the splice area. Improper positioning, movement during shrinkage or improper sizing of the sleeve, typically results in exposed conductive surfaces.</p> <p>NASA-STD-8739.4 [19.6.2.g.5]</p>
	
<p>UNACCEPTABLE IMPROPER LOCATION</p> <p>Solder sleeves should be installed, such that the solder preform is approximately centered on the stripped section of the conductors, ensuring proper sealing and strain relief.</p> <p>Best Workmanship Practice</p>	<p>UNACCEPTABLE INCOMPLETE FILLET</p> <p>The termination shall exhibit a complete, fully wetted fillet along both sides of the interface between the two conductors.</p> <p>NASA-STD-8739.4 [19.6.2.g.2], [19.6.2.g.3]</p>

NASA WORKMANSHIP STANDARDS			
 NATIONAL AERONAUTICS AND SPACE ADMINISTRATION JOHNSON SPACE CENTER HOUSTON, TEXAS USA 77058	Released: 04.05.2002	Revision:	Revision Date:
	Book: 4	Section: 4.06	Page: 2

CABLE AND HARNESS SOLDER SLEEVES (cont.)

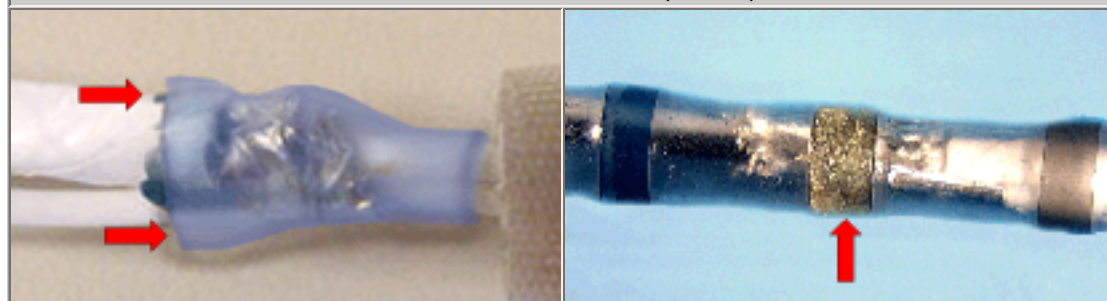

UNACCEPTABLE
IMCOMPLETE SHRINKAGE

The solder sleeve shall be completely shrunk to provide a tight fit and proper stress relief.

[NASA-STD-8739.4 \[9.10\]](#), [\[11.4\]](#), [\[19.6.1.b.6\]](#)

UNACCEPTABLE
INCOMPLETE SOLDER FLOW

The solder preform has not melted and properly flowed. Typically this is caused by insufficient heat, insufficient dwell time during the shrinkage process, or use of an infra-red (IR) heat source.

[NASA-STD-8739.4 \[19.6.2.g\]](#)

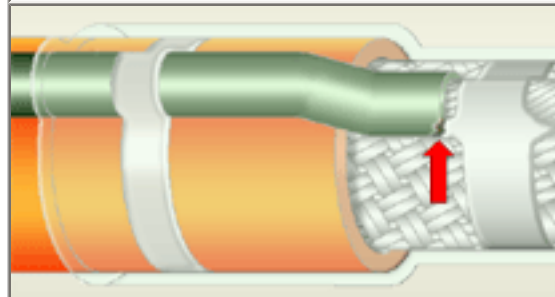

UNACCEPTABLE
INSUFFICIENT INSULATION CLEARANCE

The insulation shall not be imbedded in the solder joint. The contour of the conductor shall not be obscured at the termination end of the insulation.

[NASA-STD-8739.4 \[10.1.7.a.1\]](#)



UNACCEPTABLE
SEPARATED SHIELD STRANDS

Birdcaged or separation of the shield stranding may introduce unwanted electrical noise into the system, and may interfere with the proper installation of the solder sleeve.

[NASA-STD-8739.4 \[19.6.1.e.16\]](#)

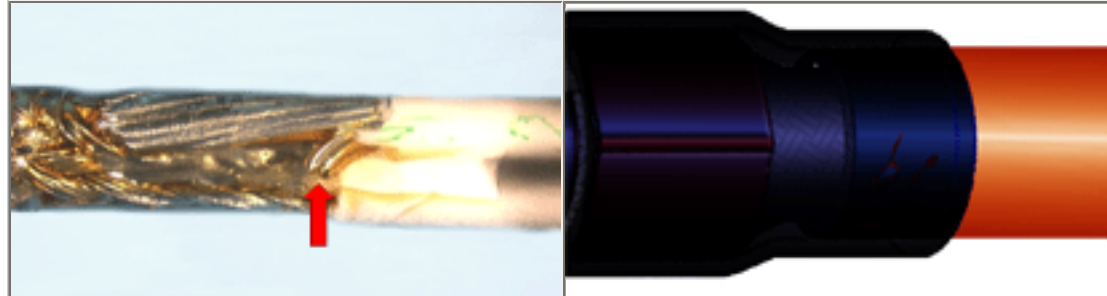

<p>UNACCEPTABLE SEVERED/PROTRUDING STRANDS</p> <p>Conductors exhibiting severed strands shall not be used. Severed wire strands may protrude through the solder sleeve, creating a shorting and reliability risk.</p> <p>NASA-STD-8739.3 [7.2.3] NASA-STD-8739.4 [19.6.2.a.2], [19.6.2.g.7]</p>	<p>UNACCEPTABLE TERMINATION NOT VISIBLE</p> <p>The solder sleeve is opaque, prohibiting visual inspection of the termination. The solder sleeve shall be transparent or translucent to allow inspection.</p> <p>NASA-STD-8739.4 [19.6.2.g.1]</p>
--	---

NASA WORKMANSHIP STANDARDS			
 <p>NATIONAL AERONAUTICS AND SPACE ADMINISTRATION JOHNSON SPACE CENTER HOUSTON, TEXAS USA 77058</p>	Released: 04.05.2002	Revision:	Revision Date:
	Book: 4	Section: 4.06	Page: 3







[Need a printed copy?](#)
(May take a while to load.)
Requires Adobe Reader.



[Need Adobe Reader?](#)
[Click here to download.](#)

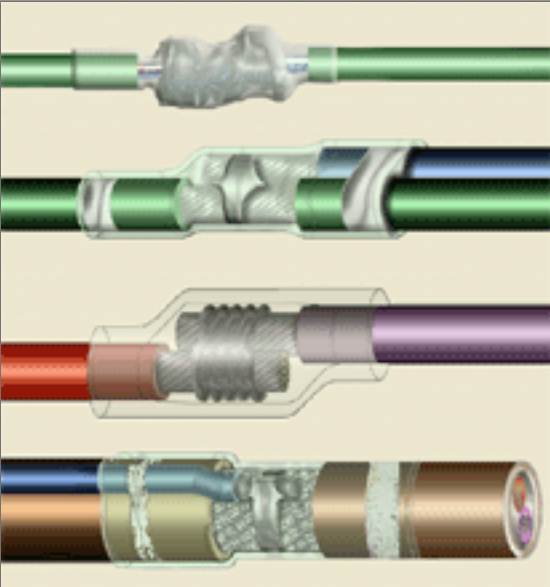

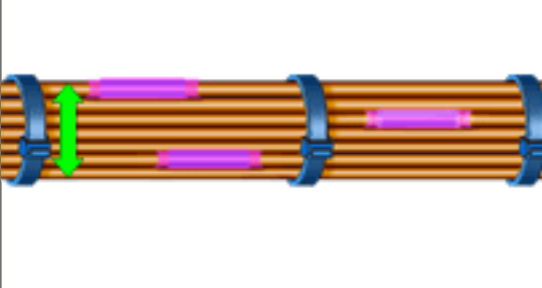
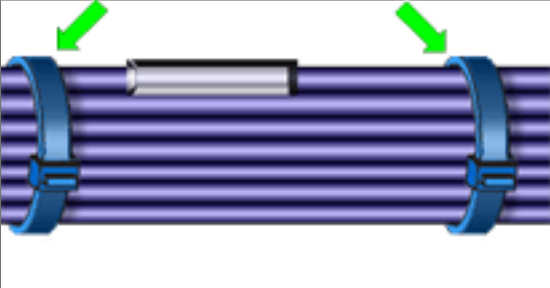
[Questions? Suggestions?](#)

CABLE AND HARNESS SPLICES	
	<p style="text-align: center;">SPLICES</p> <p>A splice is the joining of two or more conductors together in a manner that results in a permanent electrical termination and mechanical bond, and may be completed by either crimp or solder process.</p> <p>See Section 4.01 "Cable and Harness, General Requirements", and Section 6.01 "Through-Hole Soldering, General Requirements", for common accept/reject criteria.</p>
	
<p>PREFERRED GENERAL REQUIREMENTS</p> <p>The splice exhibits a smooth profile, proper strain relief, and is located in an area of the harness not subjected to flexure.</p> <p>Best Workmanship Practice</p>	<p>PREFERRED SPLICE ASSEMBLY PROFILE</p> <p>The location of splices shall be staggered to minimize the increase in profile to the harness. Final assembly profile shall not impact form, fit or function.</p> <p>Best Workmanship Practice</p>
	
<p>PREFERRED SPLICE RESTRAINT</p> <p>Cable ties/lacing shall be installed at both ends of a splice or solder sleeve, but placement shall not violate stress relief requirements.</p> <p>Best Workmanship Practice</p>	<p>ACCEPTABLE CRIMP SPLICE-BUTT/INLINE</p> <p>The contact has been deformed only by tool indenters. Indents are symmetrical and centered on the crimp barrel. No exposed base metal or other damage. Wire strand ends are visible. Proper insulation spacing (C).</p> <p>NASA-STD-8739.4 [19.6.1.c]</p>

NASA WORKMANSHIP STANDARDS



NATIONAL AERONAUTICS AND SPACE ADMINISTRATION
JOHNSON SPACE CENTER
HOUSTON, TEXAS USA 77058

Released:
04.05.2002

Revision:

Revision Date:

	Book: 4	Section: 4.07	Page: 1
--	------------	------------------	------------

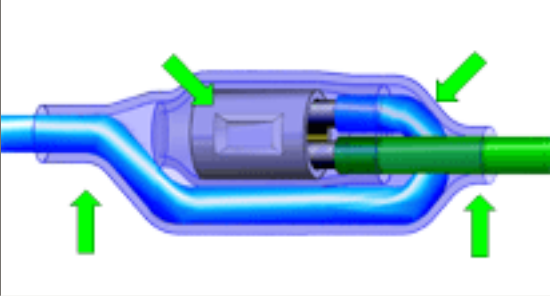
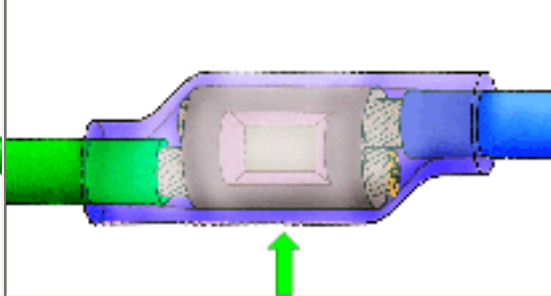
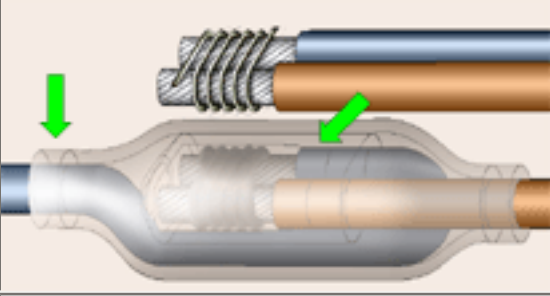
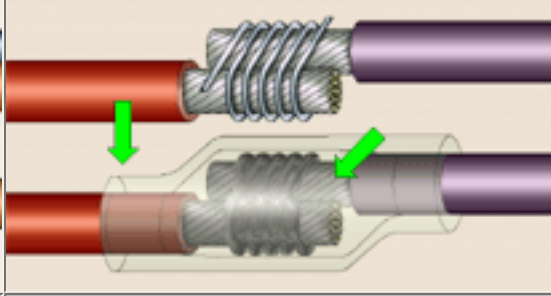
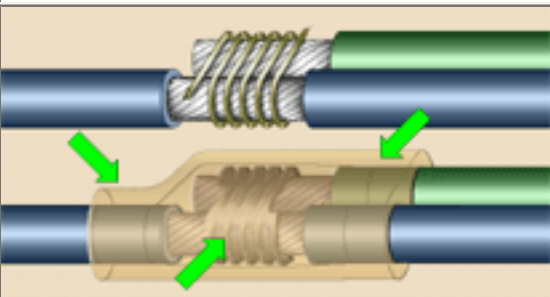
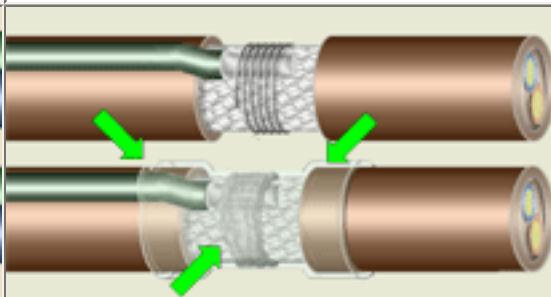
CABLE AND HARNESS SPLICES (cont.)	
	
<p>ACCEPTABLE CRIMP SPLICE - END</p> <p>Tubing is tight and symmetrical. Overlaps meet minimum electrical spacing, while providing strain relief. The termination is visible. Conductor(s) exhibit proper bend radius and strain relief.</p> <p>NASA-STD-8739.4 [19.6.1.c]</p>	<p>ACCEPTABLE CRIMP SPLICE - PARALLEL</p> <p>Tubing is tight and symmetrical. Overlaps meet minimum electrical spacing, while providing strain relief. The termination is visible. Conductor(s) exhibit proper bend radius and strain relief.</p> <p>NASA-STD-8739.4 [19.6.1.c]</p>
	
<p>ACCEPTABLE LASH SPLICE END</p> <p>The termination is fully wetted, smooth and shiny. Conductor contours are discernable. Tubing is tightly shrunk, with proper strain relief, overlap and no exposed conductive surfaces.</p> <p>Best Workmanship Practice</p>	<p>ACCEPTABLE LASH SPLICE INLINE</p> <p>The termination is fully wetted, smooth and shiny. Conductor contours are discernable. Tubing is tightly shrunk, with proper strain relief, overlap and no exposed conductive surfaces.</p> <p>Best Workmanship Practice</p>
	

<p style="text-align: center;">ACCEPTABLE LASH SPLICE INLINE BRANCH</p> <p>The termination is fully wetted, smooth and shiny. Conductor contours are discernable. Tubing is tightly shrunk, with proper strain relief, overlap and no exposed conductive surfaces.</p> <p>Best Workmanship Practice</p>	<p style="text-align: center;">ACCEPTABLE LASH SPLICE SHIELD TERMINATION (INLINE/ RUNNING)</p> <p>The termination is fully wetted, smooth and shiny. Conductor contours are discernable. Tubing is tightly shrunk, with proper strain relief, overlap and no exposed conductive surfaces.</p> <p>Best Workmanship Practice</p>
--	---

NASA WORKMANSHIP STANDARDS			
 <p>NATIONAL AERONAUTICS AND SPACE ADMINISTRATION JOHNSON SPACE CENTER HOUSTON, TEXAS USA 77058</p>	<p>Released: 04.05.2002</p>	<p>Revision:</p>	<p>Revision Date:</p>
	<p>Book: 4</p>	<p>Section: 4.07</p>	<p>Page: 2</p>

CABLE AND HARNESS SPLICES (cont.)	
	
<p style="text-align: center;">ACCEPTABLE LASH SPLICE SHIELD TERMINATION (TRADITIONAL)</p> <p>The termination is fully wetted, smooth and shiny. Conductor contours are discernable. Tubing is tightly shrunk with proper strain relief.</p> <p>Best Workmanship Practice</p>	<p style="text-align: center;">ACCEPTABLE SOLDER SLEEVE SPLICE INLINE</p> <p>The termination is fully wetted, smooth and shiny. Conductor contours are discernable. Tubing is tightly shrunk with proper strain relief, overlap and no exposed conductive surfaces.</p> <p>Best Workmanship Practice</p>
	
<p style="text-align: center;">ACCEPTABLE SOLDER SLEEVE SPLICE INLINE BRANCH</p> <p>The termination is fully wetted, smooth and shiny. Conductor contours are discernable. Tubing is tightly shrunk, with proper strain relief, overlap and no exposed conductive surfaces.</p> <p>Best Workmanship Practice</p>	<p style="text-align: center;">ACCEPTABLE SOLDER SLEEVE SPLICE SHIELD TERMINATION (INLINE)</p> <p>The termination is fully wetted, smooth and shiny. Conductor contours are discernable. Tubing is tightly shrunk, with proper strain relief, overlap and no exposed conductive surfaces.</p> <p>NASA-STD-8739.4 [11.4], [19.6.1]</p>

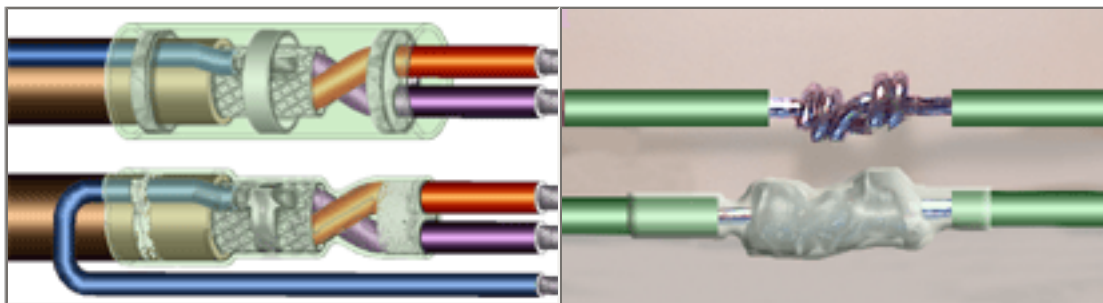

**ACCEPTABLE
SOLDER SLEEVE SPLICE
SHIELD TERMINATION (TRADITIONAL)**

The termination is fully wetted, smooth and shiny. Conductor contours are discernable. Tubing is tightly shrunk, with proper strain relief, overlap and no exposed conductive surfaces.

[NASA-STD-8739.4 \[11.4\], \[19.6.1\]](#)

**ACCEPTABLE
WESTERN UNION/LINEMAN SPLICE**

The termination is fully wetted, smooth and shiny. Tubing is tightly shrunk, with proper strain relief, overlap and no exposed conductive surfaces. Western Union splices are used for solid conductors.

[NASA-STD-8739.3 \[13.6\]](#)

NASA WORKMANSHIP STANDARDS



**NATIONAL AERONAUTICS AND
SPACE ADMINISTRATION
JOHNSON SPACE CENTER
HOUSTON, TEXAS USA 77058**

Released: 04.05.2002	Revision:	Revision Date:
Book: 4	Section: 4.07	Page: 3

**CABLE AND HARNESS
SPLICES (cont.)**

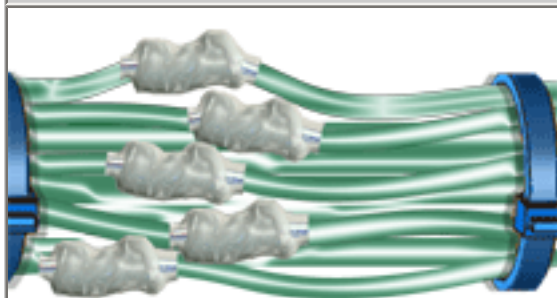

**UNACCEPTABLE
EXCESSIVE PROFILE**

The location of splices shall be staggered to minimize the increase in profile to the harness. Final assembly profile shall not impact form, fit or function.

[Best Workmanship Practice](#)

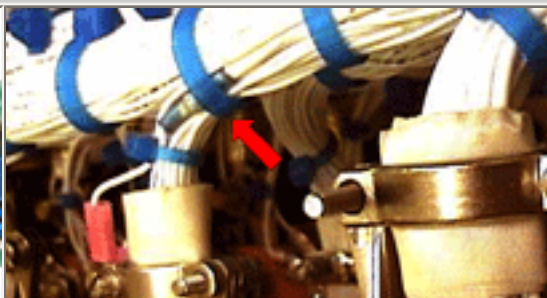

**UNACCEPTABLE
IMPROPER RESTRAINT**

Cable ties/lacing shall not be installed across the splice/ solder sleeve body, unless sufficient protection is provided to prevent compression damage to the termination and/or to the insulation of adjacent conductors.

[Best Workmanship Practice](#)

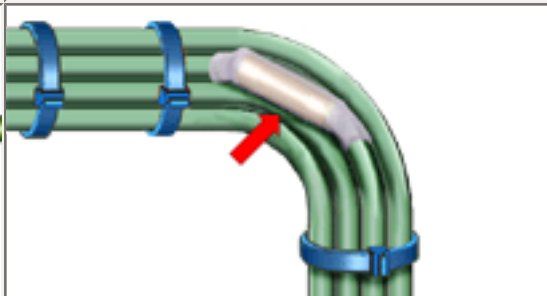
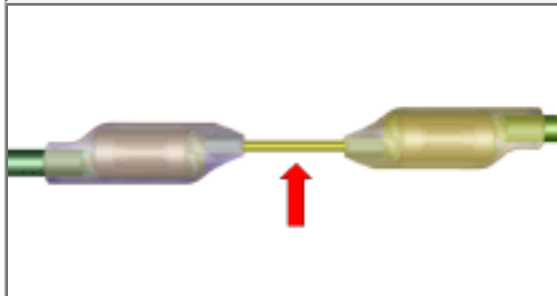

<p>UNACCEPTABLE IMPROPER SPLICE GAUGE/SIZE</p> <p>Replacement conductors shall be of the same voltage and current rating as the original conductor.</p> <p>Best Workmanship Practice</p>	<p>UNACCEPTABLE SPLICES IN FLEXURE ZONE</p> <p>Splices shall not be installed in areas where the harness is designed to flex.</p> <p>Best Workmanship Practice</p>
---	---

NASA WORKMANSHIP STANDARDS			
 <p>NATIONAL AERONAUTICS AND SPACE ADMINISTRATION JOHNSON SPACE CENTER HOUSTON, TEXAS USA 77058</p>	Released: 04.05.2002	Revision:	Revision Date:
	Book: 4	Section: 4.07	Page: 4



[Need a printed copy?](#)
(May take a while to load.)
Requires Adobe Reader.



[Need Adobe Reader?](#)
[Click here to download.](#)

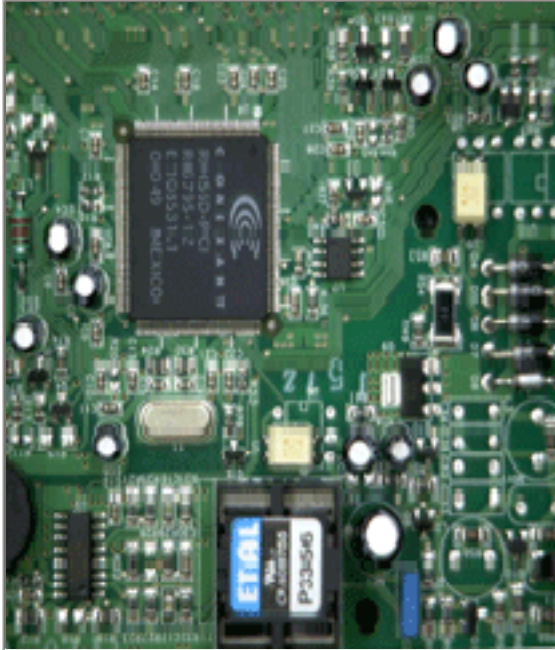
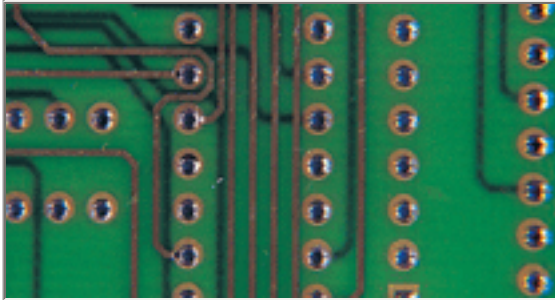
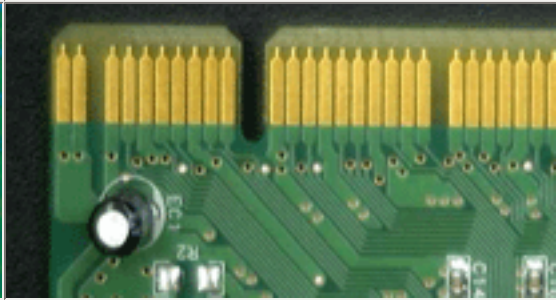
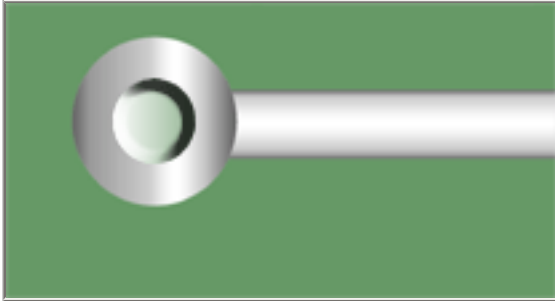
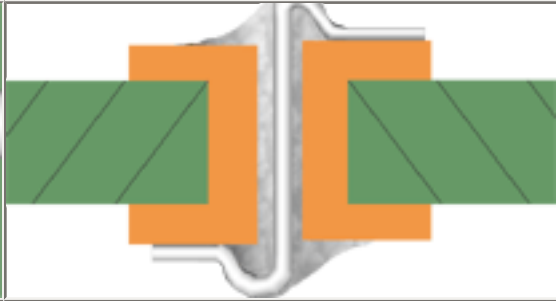

[Questions? Suggestions?](#)

PRINTED WIRING BOARD (PWB) GENERAL REQUIREMENTS		
	<p>PRINTED WIRING BOARD (PWB) GENERAL REQUIREMENTS</p> <p>The printed wiring board (PWB) is an essential part of a total electronic circuit packaging system. The design requirements of the PWB must accommodate the various components required to achieve product functionality, while meeting packaging and other product design requirements.</p> <p>Boards shall be clean and damage-free, with sharply defined conductive patterns. Plating and solder mask shall be of uniform color and finish, holes properly located, markings sharply defined and aligned, and electrical/solder termination areas bright and shiny.</p>	
		
<p>GENERAL REQUIREMENTS</p> <p>The printed wiring board is clean and damage-free, with sharply defined conductive patterns. Plated-Through Holes (PTH) and vias are properly located, clean and unfilled, and exhibit smooth and uniform plating. Electrical termination areas are bright and shiny. Solder mask exhibits proper registration.</p> <p>Best Workmanship Practice</p>	<p>PREFERRED GOLD/PRECIOUS METAL CONTACTS</p> <p>Contact surfaces are clean and bright, with a uniform and smooth finish.</p> <p>Best Workmanship Practice</p>	
		
<p>PREFERRED HOLE LOCATION/REGISTRATION</p> <p>Holes (supported/unsupported) shall be centered in the lands and located per engineering documentation. Annular ring shall be concentric to the pad.</p> <p>Best Workmanship Practice</p>	<p>PREFERRED INTERFACIAL CONNECTIONS (VIAS) DOUBLE-SIDED PWBs</p> <p>VIAs in double-sided PWBs require the use of filler wire (Z-wire) for support if the PWB coupon has not been evaluated by construction analysis (micro-section).</p> <p>NASA-STD-8739.3 [11.2.4.a]</p>	
<p>NASA WORKMANSHIP STANDARDS</p>		
	<p>Released: 04.05.2002</p>	<p>Revision:</p>
	<p>Revision Date:</p>	



NATIONAL AERONAUTICS AND SPACE ADMINISTRATION
 JOHNSON SPACE CENTER
 HOUSTON, TEXAS USA 77058

Book:
5

Section:
5.01

Page:
1

PRINTED WIRING BOARD (PWB)
 GENERAL REQUIREMENTS (cont.)



PREFERRED INTERFACIAL CONNECTIONS (VIAS) MULTI-LAYER PWBs

Vias in multi-layer PWBs do not require the use of filler wire (Z-wire), nor shall they be solder-filled. No dedicated effort shall be made to remove solder in unused holes.

[NASA-STD-8739.3 \[11.2.4.b\]](#)

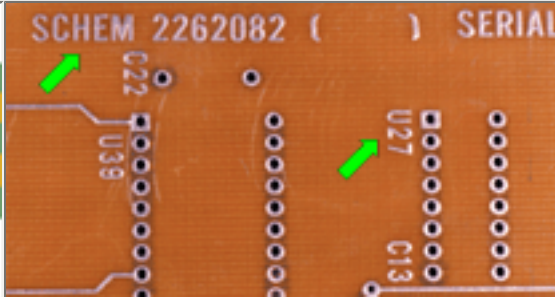

PREFERRED ETCHED LEGENDS/MARKINGS

Legends/Markings are sharply defined, of uniform size and density, correct alignment and polarity, and meet minimum electrical spacing requirements. Markings do not touch or cross over solderable surfaces.

[Best Workmanship Practice](#)

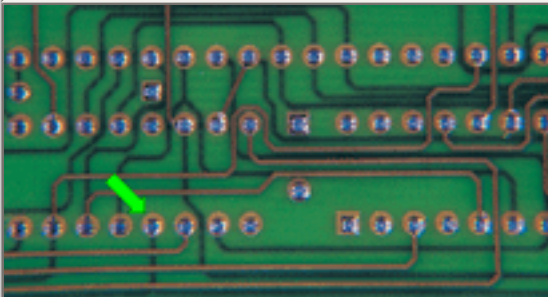

PREFERRED SOLDER MASK/RESIST COATING

Coating is uniform in color and finish. Registration is correct. No blisters, scratches, voids, waves, ripples, wrinkling, bubbles, haziness, tackiness or entrapped particles.

[Best Workmanship Practice](#)

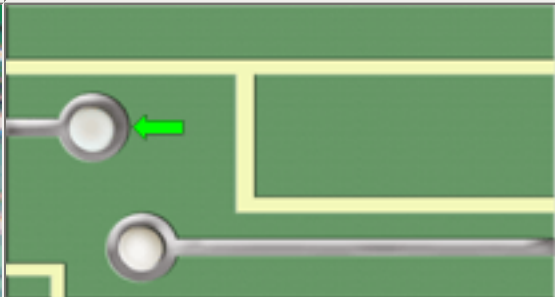

PREFERRED SUPPORTED HOLES

Supported/Plated Through Holes (PTH) designated for lead insertion exhibit a smooth/even bore and plating, proper diameter, are free of resist and have symmetrical annular rings.

[Best Workmanship Practice](#)

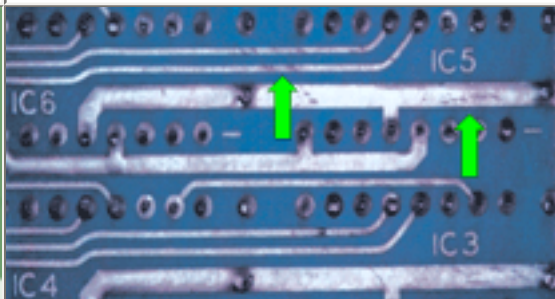
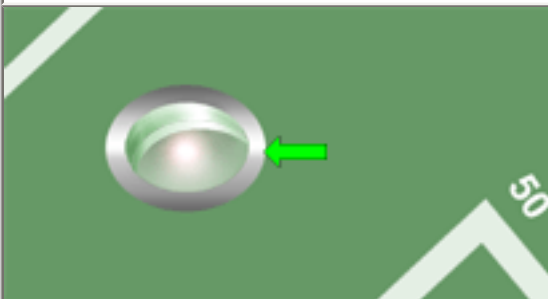

<p>PREFERRED UNSUPPORTED HOLES</p> <p>Unsupported/Non-Plated-Through Holes (NPTH) exhibit smooth/even walls, proper diameter, are free of plating and have symmetrical annular rings.</p> <p>Best Workmanship Practice</p>	<p>ACCEPTABLE DISCOLORED CONDUCTORS</p> <p>Slight dulling of clean metallic surfaces is acceptable, provided the surface conductivity or solderability is not affected.</p> <p>Best Workmanship Practice</p>
---	---

NASA WORKMANSHIP STANDARDS			
 <p>NATIONAL AERONAUTICS AND SPACE ADMINISTRATION JOHNSON SPACE CENTER HOUSTON, TEXAS USA 77058</p>	Released: 04.05.2002	Revision:	Revision Date:
	Book: 5	Section: 5.01	Page: 2

**PRINTED WIRING BOARD (PWB)
GENERAL REQUIREMENTS (cont.)**

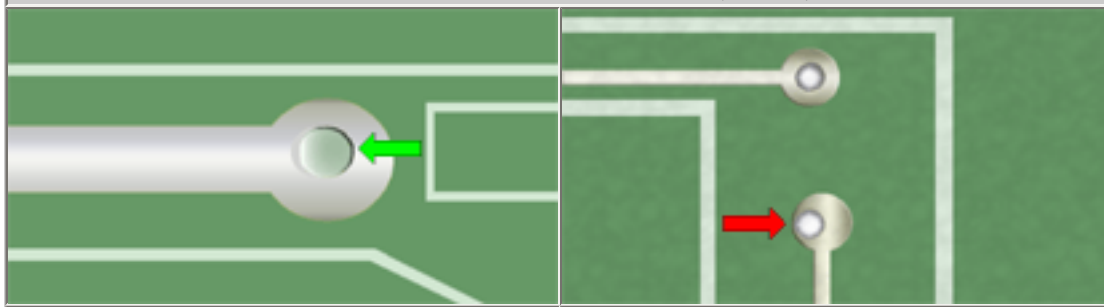

**ACCEPTABLE
ANNULAR RING**

The hole is not centered in the land, however it is acceptable providing the minimum annular ring requirement is not violated.

[Best Workmanship Practice](#)

**UNACCEPTABLE
INSUFFICIENT ANNULAR RING**

The lower hole is improperly located, causing the annular ring dimension to be less than minimum requirements.

[Best Workmanship Practice](#)

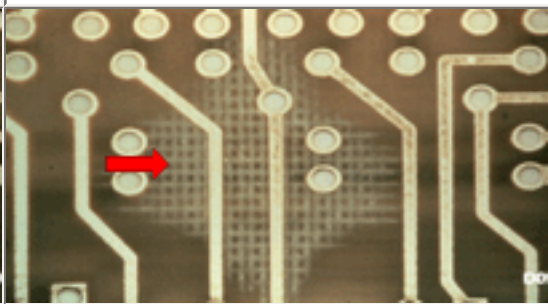
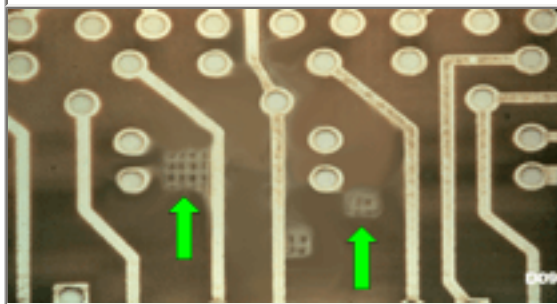

**ACCEPTABLE
CRAZING**

Crazing (whitish, discrete spots or crosses below the laminate surface) which does not bridge uncommon conductors is acceptable.

[NASA-STD-8739.2 \[12.8.2.c.3\]](#)

**UNACCEPTABLE
CRAZING**

Crazing which bridges uncommon conductors is unacceptable.

[NASA-STD-8739.2 \[12.8.2.c.3\]](#)

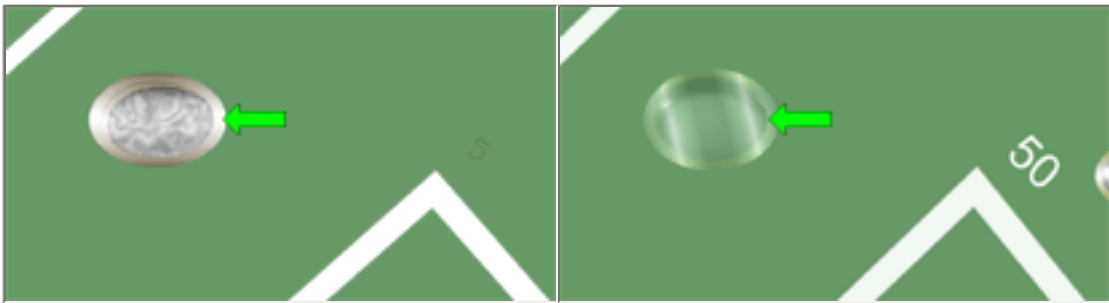

<p>ACCEPTABLE EPOXY/SOLDER FILLED VIAS/PTH</p> <p>Vias and plated-through holes, not intended for lead insertion, may be plugged by epoxy resin or solder, if documented on the engineering drawings.</p> <p>Best Workmanship Practice</p>	<p>ACCEPTABLE TENTED VIAS/PTH</p> <p>Vias and plated-through holes not intended for lead insertion may be tented by solder mask, if documented on the engineering documentation.</p> <p>Best Workmanship Practice</p>
--	---

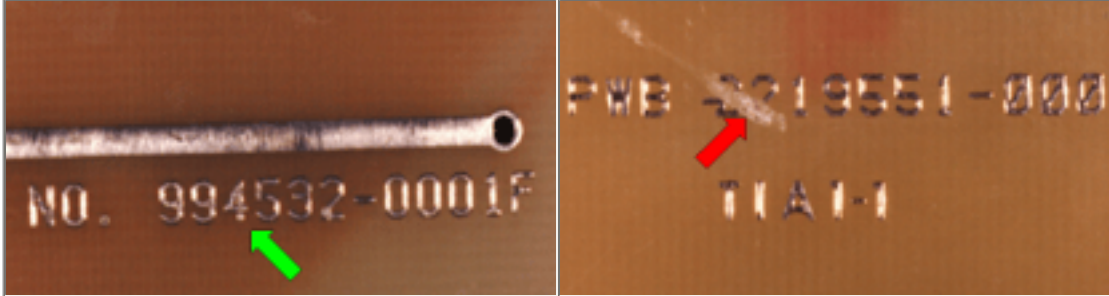

NASA WORKMANSHIP STANDARDS			
 <p>NATIONAL AERONAUTICS AND SPACE ADMINISTRATION JOHNSON SPACE CENTER HOUSTON, TEXAS USA 77058</p>	Released: 04.05.2002	Revision:	Revision Date:
	Book: 5	Section: 5.01	Page: 3

PRINTED WIRING BOARD
GENERAL REQUIREMENTS (cont.)

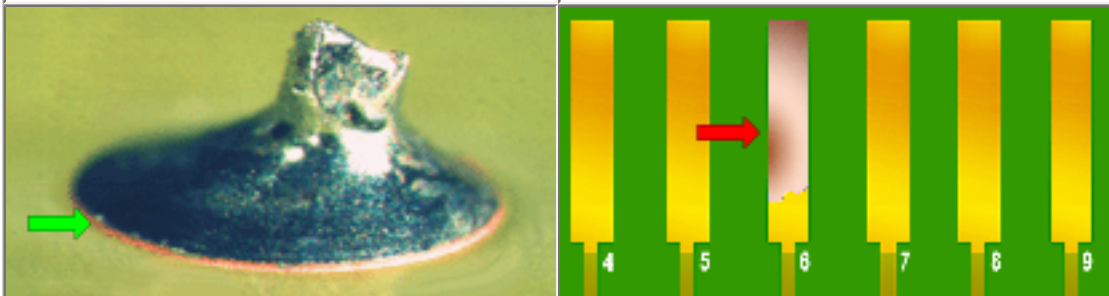

<p>ACCEPTABLE ETCHED LEGENDS/MARKINGS</p> <p>Legends/markings may exhibit slightly irregular definition, broken letters/lines, size or density, provided they are legible and/or their intent is clear.</p> <p>Best Workmanship Practice</p>	<p>UNACCEPTABLE ETCHED MARKINGS/LEGENDS</p> <p>Poor definition, improper alignment/polarity, missing characters, smudged, smeared, multiple-imaged, touch or cross over solderable surfaces, exposed copper, delamination, violate electrical spacing requirements.</p> <p>Best Workmanship Practice</p>
--	---



<p style="text-align: center;">ACCEPTABLE EXPOSED BASE METAL</p> <p>Exposed base metal on the vertical edge of printed wiring conductors, lands and pads is acceptable.</p> <p>NASA-STD-8739.2 [12.8.2.c.5] NASA-STD-8739.3 [13.6.2.c.5]</p>	<p style="text-align: center;">UNACCEPTABLE EXPOSED BASE METAL</p> <p>Defects or damage (cuts, nicks, gouges, scrapes, etc.) that result in exposed base metal (except for the vertical edges of circuit traces, lands and pads) shall be rejectable.</p> <p>NASA-STD-8739.2 [12.8.2.c.5] NASA-STD-8739.3 [13.6.2.c.5]</p>
	
<p style="text-align: center;">ACCEPTABLE LABELS</p> <p>Labels shall exhibit a flat, smooth profile, legible graphics, proper placement and adhesion. Labels shall be non-conductive and shall not be placed over components, exposed circuit traces, vias or solder terminations.</p> <p>Best Workmanship Practice</p>	<p style="text-align: center;">UNACCEPTABLE LABELS</p> <p>Labels which exhibit damage, improper placement, improper adhesion are conductive and/or placed over components, exposed circuit traces, vias or solder terminations etc., shall be rejectable.</p> <p>Best Workmanship Practice</p>

NASA WORKMANSHIP STANDARDS			
 <p>NATIONAL AERONAUTICS AND SPACE ADMINISTRATION JOHNSON SPACE CENTER HOUSTON, TEXAS USA 77058</p>	Released: 04.05.2002	Revision:	Revision Date:
	Book: 5	Section: 5.01	Page: 4

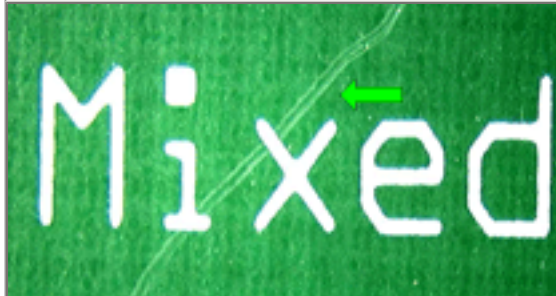
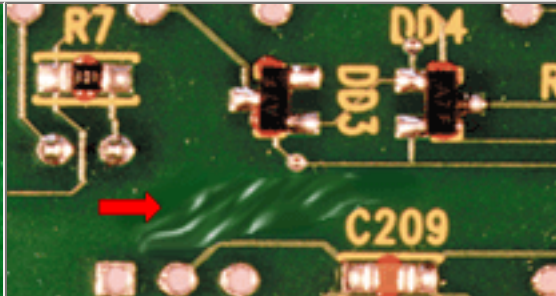
PRINTED WIRING BOARD (PWB) GENERAL REQUIREMENTS (cont.)	
	
<p style="text-align: center;">ACCEPTABLE LAMINATE SCRATCHES</p> <p>Scratches, scrapes, gouges, nicks and/or cuts to the laminate that do not expose glass fiber or reduce electrical spacing are acceptable.</p> <p>NASA-STD-8739.2 [8.7.4.c], [12.8.2.c.6]</p>	<p style="text-align: center;">UNACCEPTABLE LAMINATE SCRATCHES</p> <p>Scratches that expose glass fiber are an indication of improper process control and/or handling.</p> <p>NASA-STD-8739.2 [8.7.4.c], [12.8.2.c.6]</p>

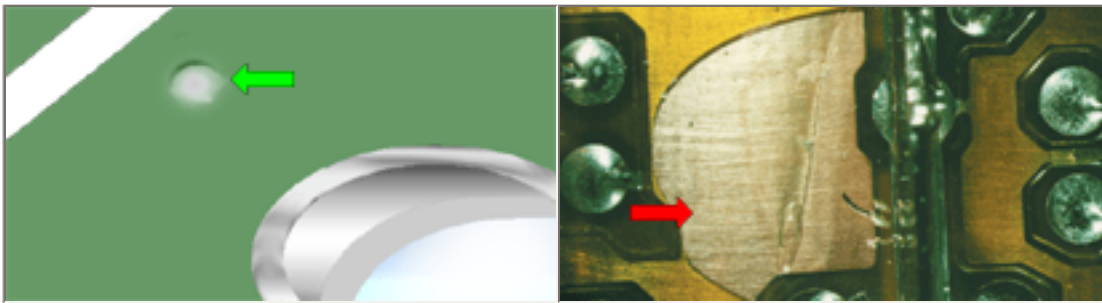

**ACCEPTABLE
LAMINATE VOIDS**

Laminate voids located a minimum of 0.003 inch (0.080 mm) from the periphery of a plated-through hole, and sized less than 0.003 inch (0.080 mm) in any dimension, are allowable.

[Best Workmanship Practice](#)

**UNACCEPTABLE
LAMINATE VOIDS**

Laminate voids located less than 0.003 inch (0.080 mm) from the periphery of a plated-through hole, and sized greater than 0.003 inch (0.080 mm) in any dimension, are not allowed.

[Best Workmanship Practice](#)

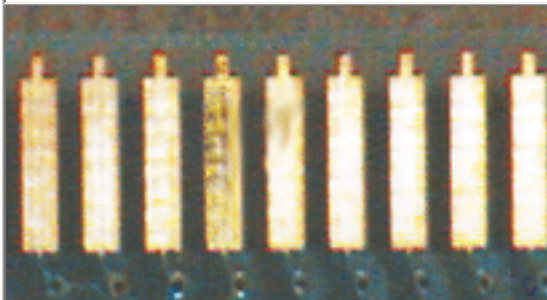

**ACCEPTABLE
PLATING**

Plating is uniform and smooth. Luster may vary from bright to slightly dull. Minor scratches, scuffing and solder on non-contact areas of fingers are allowable.

[Best Workmanship Practice](#)

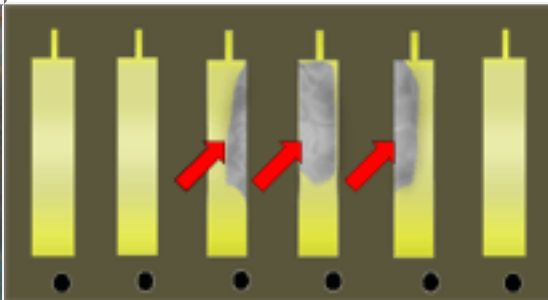

**UNACCEPTABLE
IRREGULAR PLATING**

Irregular or skipped plating is an indicator of improper process control and/or contamination.

[Best Workmanship Practice](#)

NASA WORKMANSHIP STANDARDS



**NATIONAL AERONAUTICS AND
SPACE ADMINISTRATION**
JOHNSON SPACE CENTER
HOUSTON, TEXAS USA 77058

Released:
04.05.2002

Revision:

Revision Date:

Book:
5

Section:
5.01

Page:
5

**PRINTED WIRING BOARD (PWB)
GENERAL REQUIREMENTS (cont.)**

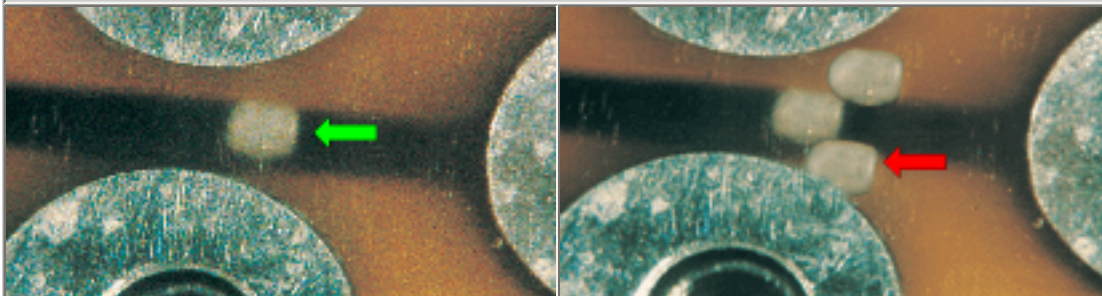

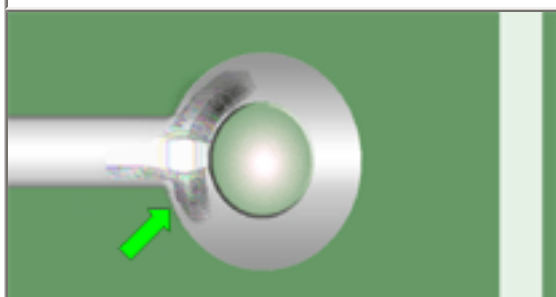
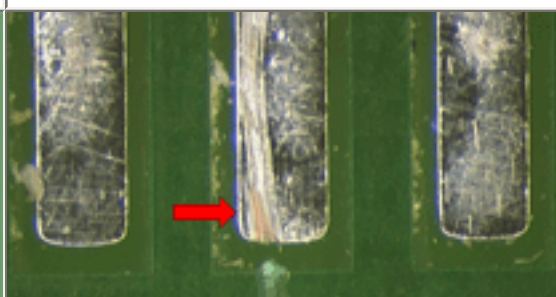
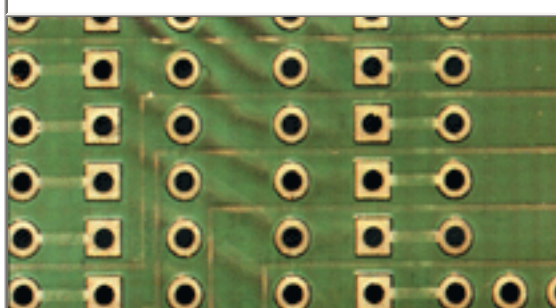
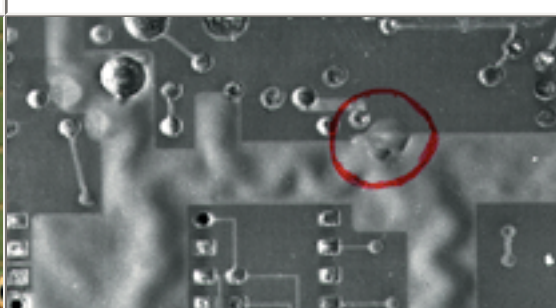
<p style="text-align: center;">ACCEPTABLE MEASLING</p> <p>Measling (whitish, discrete spots or crosses) below the laminate surface that do not bridge uncommon conductors is acceptable.</p> <p>NASA-STD-8739.2 [12.8.2.c.3]</p>	<p style="text-align: center;">UNACCEPTABLE MEASLING</p> <p>Measling (whitish, discrete spots or crosses below the laminate surface) which bridges uncommon conductors is unacceptable.</p> <p>NASA-STD-8739.2 [12.8.2.c.3]</p>
	
<p style="text-align: center;">ACCEPTABLE SMOOTH TOOL IMPRESSION MARKS</p> <p>Scratches, scrapes, gouges, nicks and/or cuts to the printed wiring pattern that do not expose base metal or reduce cross-sectional area are acceptable.</p> <p>NASA-STD-8739.2 [12.8.2.c.5]</p>	<p style="text-align: center;">UNACCEPTABLE SCRATCHES (PRINTED WIRING)</p> <p>Scratches that expose base metal are an indication of improper process control and/or handling.</p> <p>NASA-STD-8739.2 [12.8.2.c.5]</p>
	
<p style="text-align: center;">ACCEPTABLE SOLDER MASK</p> <p>Minor waves, ripples or wrinkling which do not reduce the coating below minimum thickness requirements. Isolated bubbles or void, which do not bridge conductive patterns or reduce electrical spacing requirements.</p> <p>Best Workmanship Practice</p>	<p style="text-align: center;">UNACCEPTABLE SOLDER MASK DEFECTS</p> <p>Solder mask tackiness, cracking, flaking or separation from the substrate or conductors.</p> <p>NASA-STD-8739.2 [12.8.2.c.8] NASA-STD-8739.3 [13.6.2.c.8]</p>

NASA WORKMANSHIP STANDARDS			
 <p>NATIONAL AERONAUTICS AND SPACE ADMINISTRATION JOHNSON SPACE CENTER HOUSTON, TEXAS USA 77058</p>	Released: 04.05.2002	Revision:	Revision Date:
	Book: 5	Section: 5.01	Page: 6

PRINTED WIRING BOARD (PWB)
GENERAL REQUIREMENTS (cont.)

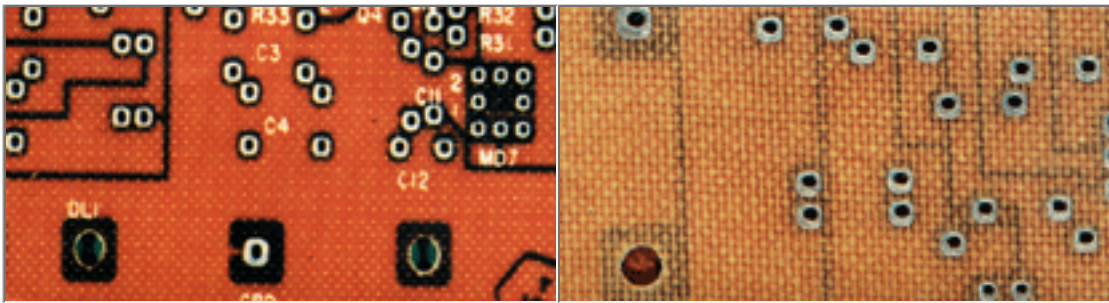

**ACCEPTABLE
WEAVE TEXTURE**

Weave texture is a visual condition in which a weave pattern is apparent, but where the glass cloth is completely covered by resin and not exposed.

[Best Workmanship Practice](#)

**UNACCEPTABLE
EXPOSED WEAVE**

Weave exposure reduces the dielectric properties between conductive patterns to less than the minimum electrical clearance.

[NASA-STD-8739.2 \[12.8.2.c.3\]](#)

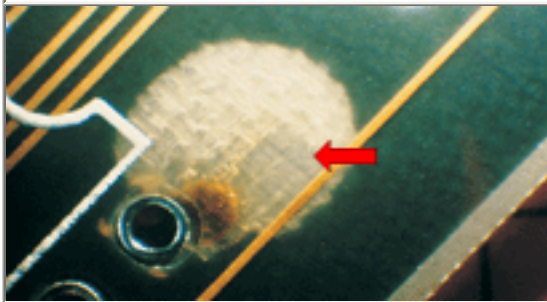

**UNACCEPTABLE
BLISTERS**

Blistering between any of the laminate layers, or between the laminate and the metallization, is not allowed.

[NASA-STD-8739.2 \[12.8.2.c.10\]](#)
[NASA-STD-8739.3 \[13.6.2.c.10\]](#)

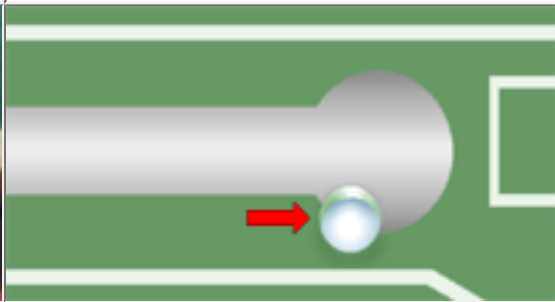

**UNACCEPTABLE
BREAK-OUT**

Break-out of the annular ring is caused by misregistration during the drilling process.

[Best Workmanship Practice](#)

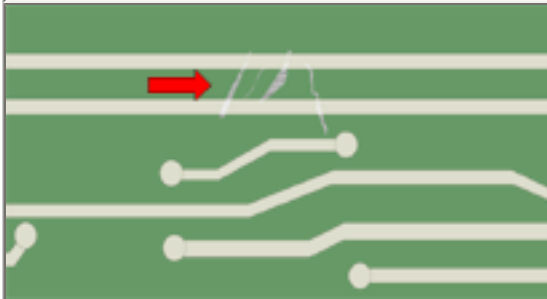

**UNACCEPTABLE
BRIDGING**

Bridging of conductive surfaces is an indication of improper process control.

[NASA-STD-8739.2 \[12.8.2.c.4\]](#)
[NASA-STD-8739.3 \[13.6.2.c.4\]](#)



**UNACCEPTABLE
CONTAMINATION**

Contamination is a reliability concern.

[NASA-STD-8739.2 \[12.8.2.b.9\]](#)

NASA WORKMANSHIP STANDARDS



**NATIONAL AERONAUTICS AND
SPACE ADMINISTRATION**
**JOHNSON SPACE CENTER
HOUSTON, TEXAS USA 77058**

Released:
04.05.2002

Revision:

Revision Date:

Book:
5

Section:
5.01

Page:
7

PRINTED WIRING BOARD (PWB) GENERAL REQUIREMENTS (cont.)				
<p style="text-align: center;">UNACCEPTABLE CONTAMINATED PLATING</p> <p>Plating is not uniform, smooth, bright and/or shiny. Solder or other contamination on the contact area shall be cause for rejection.</p> <p>Best Workmanship Practice</p>	<p style="text-align: center;">UNACCEPTABLE CORROSION</p> <p>Corrosion is a reliability concern.</p> <p>NASA-STD-8739.2 [7.4.1.d]</p>			
<p style="text-align: center;">UNACCEPTABLE CRACKED/RINGED BARREL</p> <p>Cracks or ringing in the barrel are cause for rejection.</p> <p>Best Workmanship Practice</p>	<p style="text-align: center;">UNACCEPTABLE CUT/DAMAGED PATTERN</p> <p>Repaired or damaged printed wiring conductor pattern shall be cause for rejection.</p> <p>NASA-STD-8739.2 [12.8.2.c.9] NASA-STD-8739.3 [13.6.2.c.9]</p>			
<p style="text-align: center;">UNACCEPTABLE DEMETALLIZATION/LEACHING</p> <p>Boards exhibiting leaching or loss of metallization shall be rejected.</p> <p>Best Workmanship Practice</p>	<p style="text-align: center;">UNACCEPTABLE DISCOLORATION</p> <p>Contamination or improper drying typically causes discoloration of the laminate or solder mask in the patterns depicted. Re-cleaning/Demoisturizing may correct this problem, provided no other damage is apparent.</p> <p>Best Workmanship Practice</p>			
NASA WORKMANSHIP STANDARDS				
	<table border="1" style="width: 100%;"> <tr> <td style="width: 33%;">Released: 04.05.2002</td> <td style="width: 33%;">Revision:</td> <td style="width: 33%;">Revision Date:</td> </tr> </table>	Released: 04.05.2002	Revision:	Revision Date:
Released: 04.05.2002	Revision:	Revision Date:		



PRINTED WIRING BOARD (PWB)
 GENERAL REQUIREMENTS (cont.)

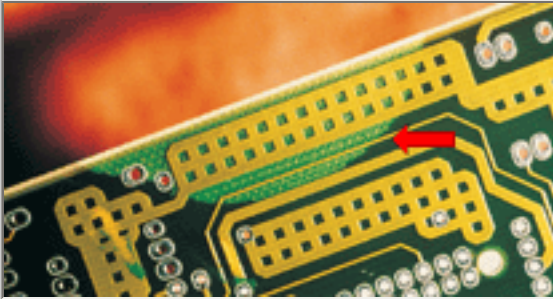

UNACCEPTABLE
 EDGE DELAMINATION

Edge delamination is an indicator of improper tooling, process control or handling.

[NASA-STD-8739.2 \[12.8.2.c.7\]](#)

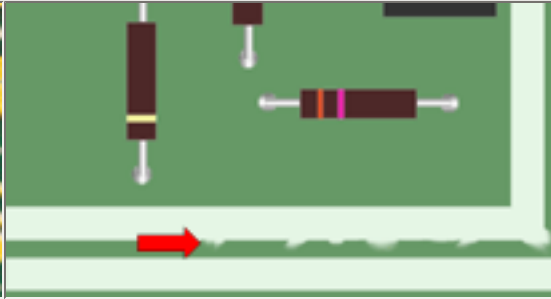

UNACCEPTABLE
 EDGE PROJECTIONS

Edge projections that reduce electrical separation below minimum requirements are rejectable.

[Best Workmanship Practice](#)

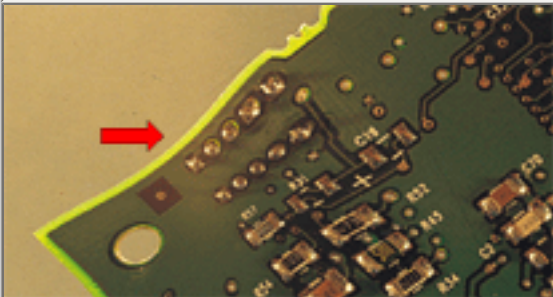

UNACCEPTABLE
 EXCESSIVE BOW/TWIST

Excessive bow or twist may inhibit proper mounting and may result in mechanical interference or shorting to adjacent assemblies or chassis.

[Best Workmanship Practice](#)

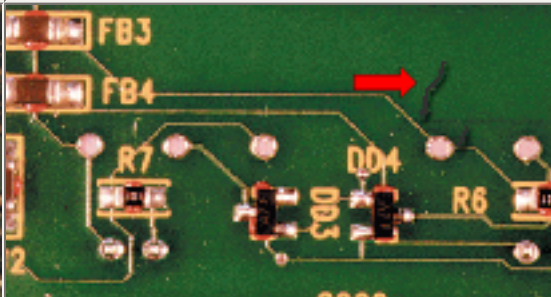

UNACCEPTABLE
 EXPOSED/PROTRUDING GLASS FIBERS

Exposed glass fiber in the laminate indicates a process control problem and is a long-term reliability concern.

[NASA-STD-8739.2 \[12.8.2.c.6\]](#)

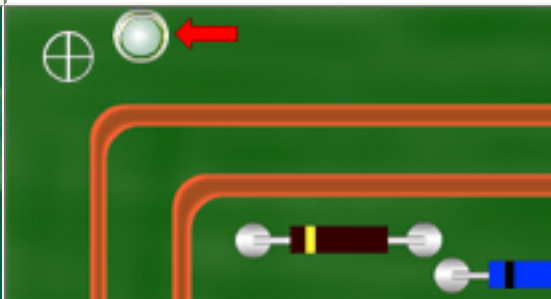
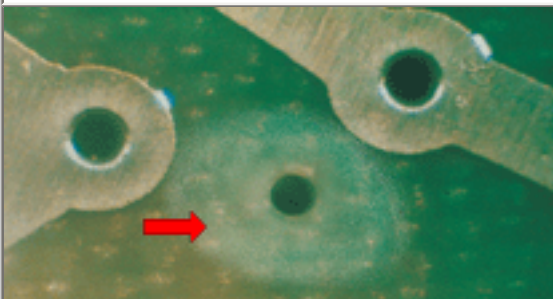

<p>UNACCEPTABLE HALO EFFECT</p> <p>A lightened area around a hole or via, typically induced by mechanical stress. Haloing which bridges uncommon conductors is unacceptable.</p> <p>NASA-STD-8739.2 [12.8.2.c.3]</p>	<p>UNACCEPTABLE IMPROPER HOLE LOCATION</p> <p>The improper location of holes (i.e.: component lead, via, mounting, etc.) is caused by misregistration during the drilling process.</p> <p>Best Workmanship Practice</p>
---	--

NASA WORKMANSHIP STANDARDS			
 <p>NATIONAL AERONAUTICS AND SPACE ADMINISTRATION JOHNSON SPACE CENTER HOUSTON, TEXAS USA 77058</p>	Released: 04.05.2002	Revision:	Revision Date:
	Book: 5	Section: 5.01	Page: 9

PRINTED WIRING BOARDS (PWB)
GENERAL REQUIREMENTS (cont.)

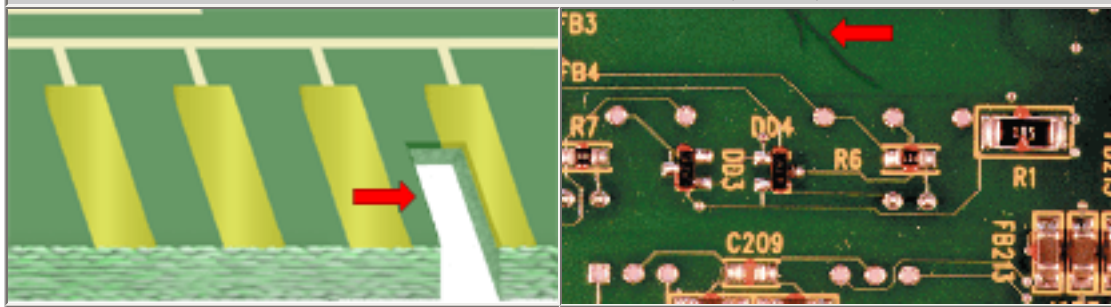

UNACCEPTABLE
IMPROPER PUNCH-OUT/NOTCH/
ROUTING

The improper location of punch-out, notching or routing is caused by misregistration or improper process control.

[Best Workmanship Practice](#)

UNACCEPTABLE
LAMINATE CRACKS

Cracks in the laminate are cause for rejection.

[NASA-STD-8739.2 \[12.8.2.c.6\]](#)

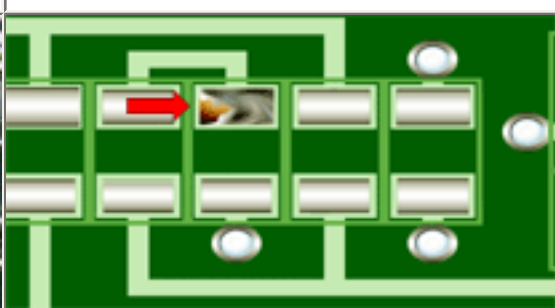
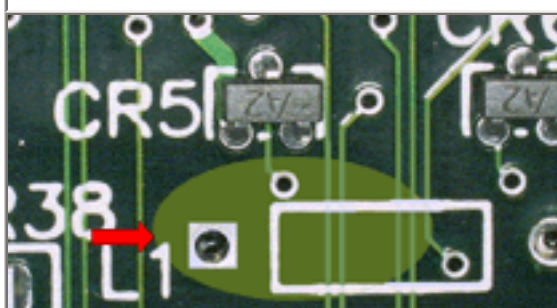

UNACCEPTABLE
LAYER DELAMINATION

Delamination between any of the laminate layers, or between the laminate and the metallization, is not allowed.

[NASA-STD-8739.2 \[12.8.2.c.7\]](#)

UNACCEPTABLE
NON-WETTING

Tin, tin/lead reflowed or solder coated surfaces, exhibiting non-wetting on any conductive surface where a solder connection will be required shall be rejected.

[Best Workmanship Practice](#)

<p style="text-align: center;">UNACCEPTABLE OVER-ETCH</p> <p>Conductors that are over-etched are incapable of carrying the designed current load, and are susceptible to reduced reliability.</p> <p>Best Workmanship Practice</p>	<p style="text-align: center;">UNACCEPTABLE PINK RING</p> <p>Pink ring is caused by a thinning of the oxide coating on the copper layer in the through-hole/inner-layer interface zone, and is considered an indicator of a process control problem.</p> <p>Best Workmanship Practice</p>

NASA WORKMANSHIP STANDARDS

 <p>NATIONAL AERONAUTICS AND SPACE ADMINISTRATION JOHNSON SPACE CENTER HOUSTON, TEXAS USA 77058</p>	<p>Released: 04.05.2002</p>	<p>Revision:</p>	<p>Revision Date:</p>
	<p>Book: 5</p>	<p>Section: 5.01</p>	<p>Page: 10</p>

**PRINTED WIRING BOARD (PWB)
GENERAL REQUIREMENTS (cont.)**

<p style="text-align: center;">UNACCEPTABLE REDUCED CROSS-SECTIONAL AREA</p> <p>Conductors that exhibit reductions in cross-sectional area are incapable of carrying the designated current load and are susceptible to reduced reliability.</p> <p>Best Workmanship Practice</p>	<p style="text-align: center;">UNACCEPTABLE REPAIRED CONDUCTOR PATTERN</p> <p>Repairs to damaged printed wiring conductor pattern shall only be made after authorization, and by approval process.</p> <p>NASA-STD-8739.2 [12.8.2.c.9] NASA-STD-8739.3 [13.6.2.c.9]</p>

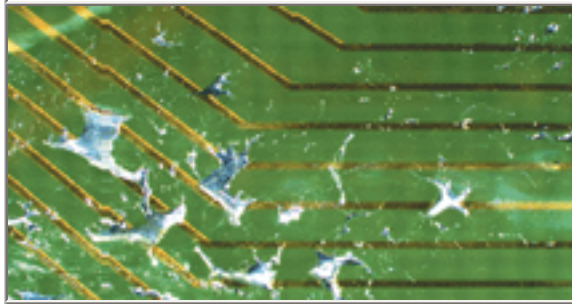
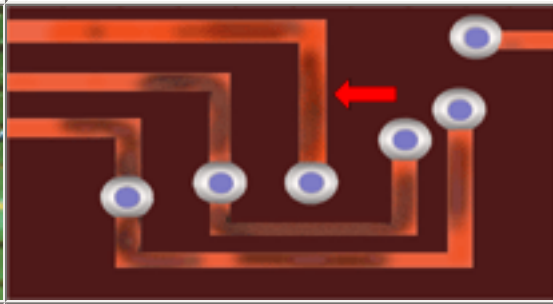
<p style="text-align: center;">UNACCEPTABLE</p> <p style="text-align: center;">ROUGH/UNEVEN EDGES (LAMINATE)</p> <p>Edges which are rough or uneven present a handling or sharp edge/protrusion hazard. Additionally, the presence of a rough or uneven edge may increase the potential for delamination of multi-layer boards.</p> <p>Best Workmanship Practice</p>	<p style="text-align: center;">UNACCEPTABLE</p> <p style="text-align: center;">SOLDER MASK MISREGISTRATION</p> <p>Solder mask misregistration violating minimum annular ring requirements. Presence of mask material in plated-through holes designated to be soldered.</p> <p>Best Workmanship Practice</p>
	
<p style="text-align: center;">UNACCEPTABLE</p> <p style="text-align: center;">SOLDER SPLATTER/WEBBING</p> <p>Solder splatter and webbing is typically caused by moisture, contamination or improper laminate bake-out, and is a reliability and short-circuit concern.</p> <p>NASA-STD-8739.2 [12.8.2.c.4]</p>	<p style="text-align: center;">UNACCEPTABLE</p> <p style="text-align: center;">UNDER-ETCH</p> <p>Under-etch is an indicator of improper process control/ improper chemistry during etching. Under-etch can result in bridging between traces, resulting in short circuits.</p> <p>Best Workmanship Practice</p>

NASA WORKMANSHIP STANDARDS

 <p>NATIONAL AERONAUTICS AND SPACE ADMINISTRATION JOHNSON SPACE CENTER HOUSTON, TEXAS USA 77058</p>	Released: 04.05.2002	Revision:	Revision Date:
	Book: 5	Section: 5.01	Page: 11



[Need a printed copy?](#)
(May take a while to load.)
 Requires Adobe Reader.



[Need Adobe Reader?](#)
[Click here to download.](#)



[Questions? Suggestions?](#)

PRINTED WIRING BOARD
RIGID LAMINATE

RIGID LAMINATE

A rigid printed wiring board is a board construction method using only rigid base materials to produce what is classically known as a printed wiring board (PWB).

The printed board may be single-sided, double-sided with or without plated-through holes, multi-layer with plated-through holes, multilayer with or without buried/blind vias and metal core.

See Section 5.01 "Printed Wiring Board, General Requirements", for common accept/reject criteria.

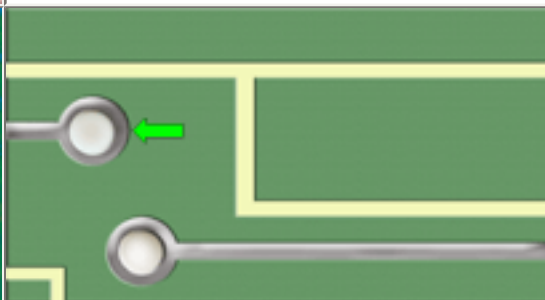
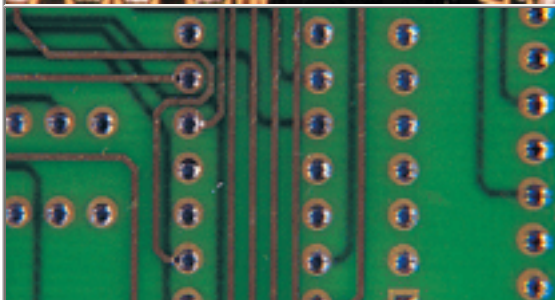
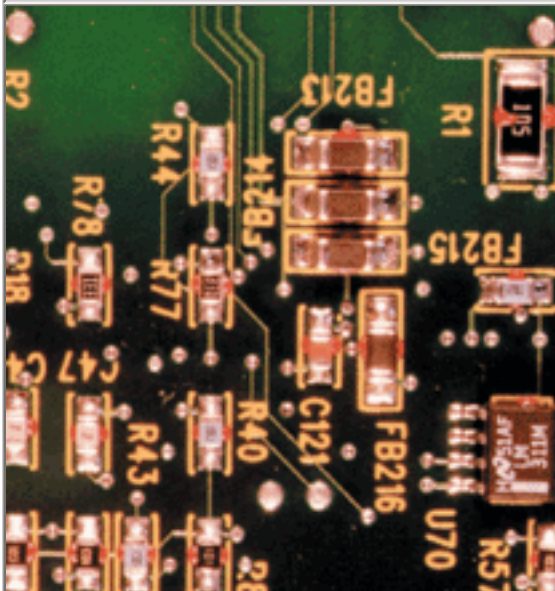

GENERAL REQUIREMENTS

Board is clean, flat and damage-free. Conductive patterns are sharply defined. Plating and solder mask are of uniform color and finish, holes are properly located, markings are sharply defined and aligned, and electrical/solder termination areas are bright and shiny.

PREFERRED
SUPPORTED HOLES

Supported/plated-through holes (PTH) designated for lead insertion exhibit a smooth/even bore and plating, proper diameter, are free of resist and have symmetrical annular rings.

[Best Workmanship Practice](#)



PREFERRED
UNSUPPORTED HOLES

Unsupported/non-plated-through holes (NPTH) exhibit smooth/even walls, proper diameter, are free of plating and have symmetrical annular rings.

[Best Workmanship Practice](#)

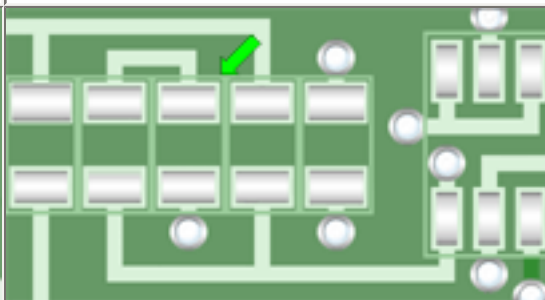

PREFERRED
SURFACE MOUNT TERMINATION PADS

Electrical/solder termination areas are clean, bright and shiny. Solder mask is of uniform color, finish and orientation. Markings are sharply defined and properly aligned.

[Best Workmanship Practice](#)

NASA WORKMANSHIP STANDARDS



NATIONAL AERONAUTICS AND
SPACE ADMINISTRATION
JOHNSON SPACE CENTER
HOUSTON, TEXAS USA 77058

Released:
04.05.2002

Revision:

Revision Date:

	Book: 5	Section: 5.02	Page: 1
--	------------	------------------	------------



[Need a printed copy?](#)
(May take a while to load.)
Requires Adobe Reader.



[Need Adobe Reader?](#)
[Click here to download.](#)



[Questions? Suggestions?](#)

**PRINTED WIRING BOARD
FLEXIBLE LAMINATE**

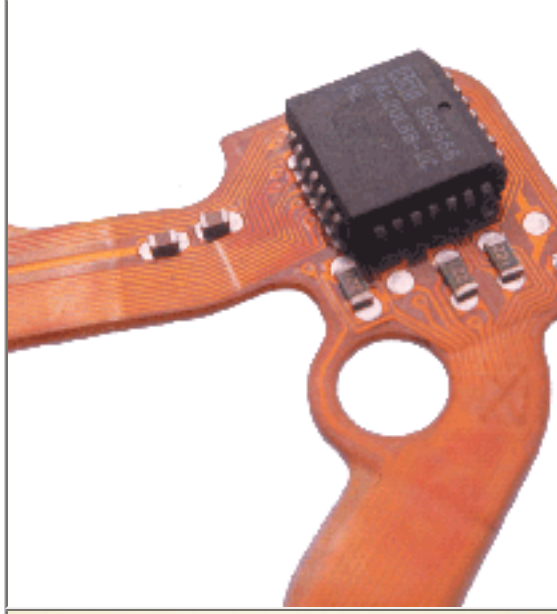

FLEXIBLE LAMINATE

The thin films used in flexible circuitry offer significant width and space savings over traditional rigid designs and allow the development of printed boards that can be bent and folded in three-dimensional (3-D) configurations. Flexible boards may be single, double or multi-layer; may contain through-hole, surface mount or mixed technology; and, can be constructed wholly of flex or a combination of both flex and rigid (see rigid-flex, section 5.04).

See Section 5.01 "Printed Wiring Board, General Requirements", for common accept/reject criteria.

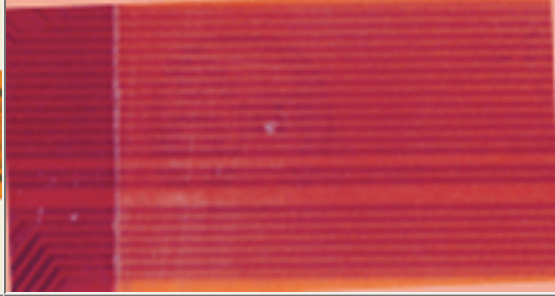

**PREFERRED
GENERAL**

Flexible circuit is clean, smooth, of uniform thickness and free of damage. Solderable surfaces are clean and bright. Markings are legible and properly oriented.

**PREFERRED
COVERFILM**

The coverfilm is smooth, clean and of uniform thickness. There is no evidence of bubbles, creases, delamination, entrapped particles, gouges, tears or ripples. Alignment and registration are correct.

[Best Workmanship Practice](#)

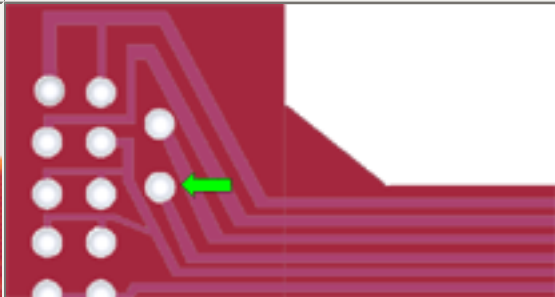
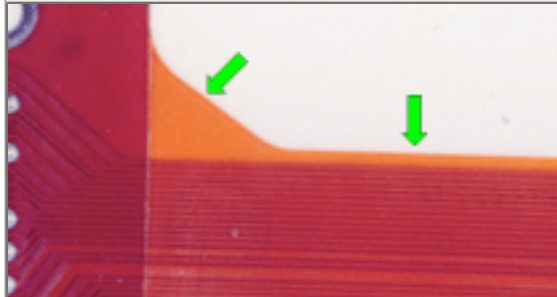

**PREFERRED
TRIMMED EDGE**

The trimmed edge shall be free of burrs, nicks, delamination or tears. Minimum edge to conductor spacing shall be maintained.

[Best Workmanship Practice](#)

**ACCEPTABLE
COVERFILM REGISTRATION**

The coverfilm is aligned and registered within engineering specification. All annular ring cutouts are centered, and there is no evidence of unwanted material on land areas.

[Best Workmanship Practice](#)

NASA WORKMANSHIP STANDARDS

Released: 04.05.2002	Revision:	Revision Date:
-------------------------	-----------	----------------



NATIONAL AERONAUTICS AND SPACE ADMINISTRATION
 JOHNSON SPACE CENTER
 HOUSTON, TEXAS USA 77058

Book:
5

Section:
5.03

Page:
1

PRINTED WIRING BOARD FLEXIBLE LAMINATE (cont.)	
<p style="text-align: center;">ACCEPTABLE EDGE NICKS</p> <p>Nicks along the edges of the flexible printed wiring, cutouts and unsupported holes are acceptable, provided minimum edge to conductor spacing is maintained and damage is within agreed-upon limits.</p> <p>Best Workmanship Practice</p>	<p style="text-align: center;">ACCEPTABLE PLATED SURFACES</p> <p>Plating is uniform, smooth and shiny. Holes are smooth and clean. No evidence of solder wicking/plating migration.</p> <p>Best Workmanship Practice</p>
<p style="text-align: center;">ACCEPTABLE SURFACE ROUGHNESS/SCUFFING</p> <p>Minor roughness or scuffing of the laminate surface is acceptable, provided the damage does not reduce reliability or interfere with the design of service/operability.</p> <p>Best Workmanship Practice</p>	<p style="text-align: center;">ACCEPTABLE TIE-IN TAB TEARS</p> <p>Minor nicks and tears that result from the use of tie-in tab design are acceptable, provided the damage does not reduce edge to conductor spacing below minimum requirements, or exceed the damage requirement agreement.</p> <p>Best Workmanship Practice</p>

<p>UNACCEPTABLE CREASES</p> <p>Creases reduce the current carrying capability and reliability of the printed conductors and the bond integrity of the laminate. Flexible circuits shall exhibit proper bend radius and strain relief.</p> <p>Best Workmanship Practice</p>	<p>UNACCEPTABLE EDGE NICKS</p> <p>Nicks along the edges of the flexible printed wiring, cutouts and unsupported holes which reduce minimum edge to conductor spacing below minimum requirements or expose conductive surfaces, are unacceptable.</p> <p>Best Workmanship Practice</p>
---	--

NASA WORKMANSHIP STANDARDS			
 <p>NATIONAL AERONAUTICS AND SPACE ADMINISTRATION JOHNSON SPACE CENTER HOUSTON, TEXAS USA 77058</p>	Released: 04.05.2002	Revision:	Revision Date:
	Book: 5	Section: 5.03	Page: 2

PRINTED WIRING BOARD
FLEXIBLE LAMINATE (cont.)

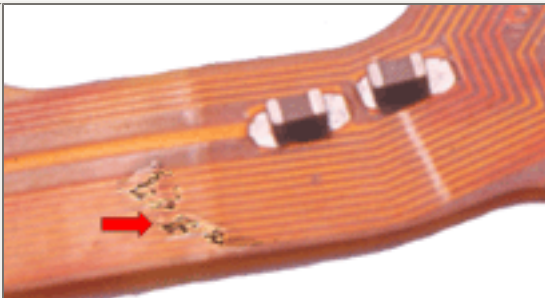
	
<p>UNACCEPTABLE FOREIGN MATERIAL IN COVERCOAT</p> <p>Foreign material under the covercoat represents a contamination and reliability concern.</p> <p>Best Workmanship Practice</p>	<p>UNACCEPTABLE PHYSICAL DAMAGE</p> <p>Cuts, nicks, gouges, tears or other physical damage that result in exposed circuitry or reduce electrical separation below minimum requirements are unacceptable.</p> <p>Best Workmanship Practice</p>

NASA WORKMANSHIP STANDARDS

 NATIONAL AERONAUTICS AND SPACE ADMINISTRATION JOHNSON SPACE CENTER HOUSTON, TEXAS USA 77058	Released: 04.05.2002	Revision:	Revision Date:
	Book: 5	Section: 5.03	Page: 3





[Need a printed copy?](#)
(May take a while to load.)
Requires Adobe Reader.



[Need Adobe Reader?](#)
[Click here to download.](#)

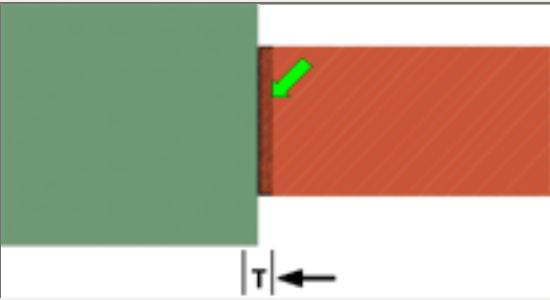
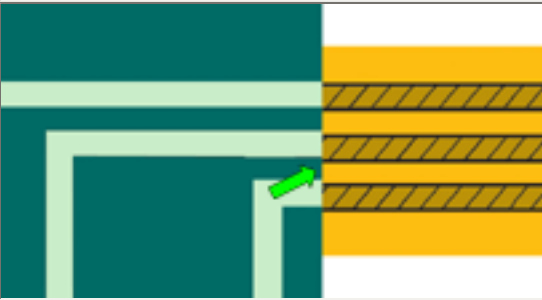

[Questions? Suggestions?](#)

PRINTED WIRING BOARD RIGID-FLEXIBLE LAMINATE	
	<p>RIGID-FLEXIBLE LAMINATE</p> <p>Rigid-Flexible Laminate (Rigid-flex) incorporates two printed wiring board technologies (rigid and flexible), allowing the development of rigid printed boards with flexible printed board interconnects, which allow the system to be bent and folded, or stacked, in three-dimensional (3-D) configurations.</p> <p>See Section 5.01 "Printed Wiring Board, General Requirements", through 5.03 "Printed Wiring Board, Flexible Laminate" for common accept/reject criteria.</p>
	
<p>PREFERRED GENERAL</p> <p>Flexible and rigid circuits are clean, smooth, of uniform thickness and free of damage. Solderable surfaces are clean and bright. Markings are legible and properly oriented.</p>	<p>PREFERRED RIGID/FLEX REGISTRATION</p> <p>The flex laminate is perfectly aligned and registered to the printed laminate.</p> <p>Best Workmanship Practice</p>
	
<p>PREFERRED TRANSITION ZONE (T)</p> <p>The transition zone between the rigid and flexible laminates is smooth, of uniform thickness and free of damage, deformation or contaminants.</p> <p>Best Workmanship Practice</p>	<p>ACCEPTABLE RIGID/FLEX REGISTRATION</p> <p>The flex laminate is aligned and registered to the printed laminate within engineering specification.</p> <p>Best Workmanship Practice</p>

NASA WORKMANSHIP STANDARDS



**NATIONAL AERONAUTICS AND
SPACE ADMINISTRATION**
JOHNSON SPACE CENTER
HOUSTON, TEXAS USA 77058

Released:
04.05.2002

Revision:

Revision Date:

	Book: 5	Section: 5.04	Page: 1
--	------------	------------------	------------

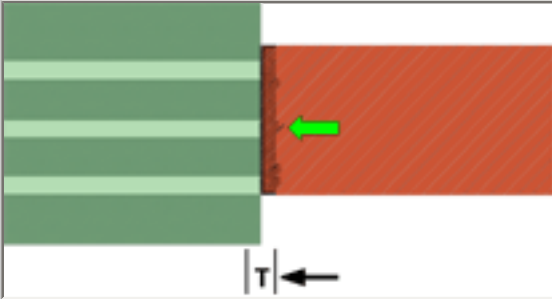
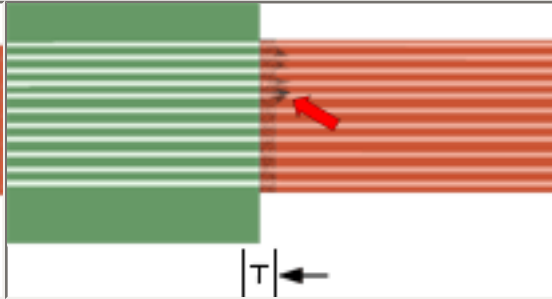
PRINTED WIRING BOARD RIGID-FLEXIBLE LAMINATE (cont.)	
	
<p>ACCEPTABLE TRANSITION ZONE IMPERFECTIONS</p> <p>Minor visual imperfections inherent to the fabrication process (i.e., adhesive squeeze-out, localized deformation of the dielectric and conductors) shall not be cause for rejection.</p> <p>Best Workmanship Practice</p>	<p>UNACCEPTABLE TRANSITION ZONE IMPERFECTIONS ADHESIVE/PREPREG SQUEEZE OUT</p> <p>The squeeze-out of adhesive/prepreg shall not extend beyond the transition zone and shall not interfere with the designed flexing of the flexible laminate.</p> <p>Best Workmanship Practice</p>

NASA WORKMANSHIP STANDARDS			
 <p>NATIONAL AERONAUTICS AND SPACE ADMINISTRATION JOHNSON SPACE CENTER HOUSTON, TEXAS USA 77058</p>	Released: 04.05.2002	Revision:	Revision Date:
	Book: 5	Section: 5.04	Page: 2



[Need a printed copy?](#)
(May take a while to load.)
Requires Adobe Reader.



[Need Adobe Reader?](#)
[Click here to download.](#)



[Questions? Suggestions?](#)

**THROUGH-HOLE SOLDERING
GENERAL REQUIREMENTS**



THROUGH-HOLE SOLDERING
GENERAL REQUIREMENTS

Discrete components are the backbone of the electronics world, consisting of individually packaged, leaded devices, highly integrated circuits (IC), interconnects, terminators, switches, etc.

While discretes are rapidly being displaced by the smaller-form surface mount technology (SMT) package, the discrete component is still widely in use, especially in extreme environmental applications where the SMT device will not perform reliability and/or is unavailable.

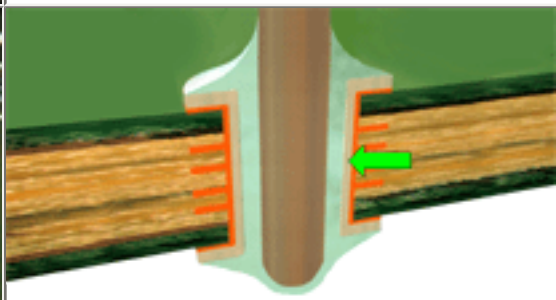

GENERAL REQUIREMENTS

Components are installed per engineering documentation and are parallel to, and in contact with, the board surface. Component and board markings are clear and legible. Component leads exhibit proper bend radii and stress relief. Solder fillets are smooth and shiny with concave profiles.

**PREFERRED
100% SOLDER FILL (PTH)**

Populated plated through holes (PTH) should exhibit a vertical solder fill of 100%, with a fully formed fillet on the solder side, and evidence of 100% wetting on the component side lead, barrel and pad.

[Best Workmanship Practice](#)

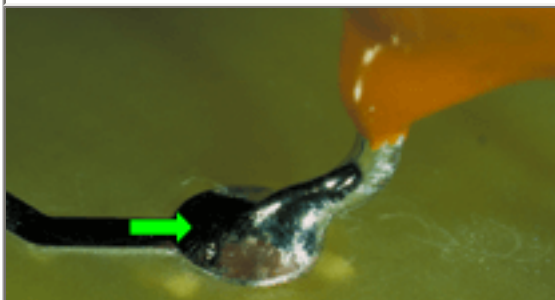

**PREFERRED
PWB COMPONENT SIDE FILLET (PTH)**

The solder joint surface is smooth, nonporous and undisturbed, with a finish varying from satin to bright. The fillet completely wets all elements to the periphery of the connection and is concave.

[NASA-STD-8739.3 \[13.6.1.f.2\]](#)

**PREFERRED
SOLDER SIDE FILLETS (PTH/NPTH)**

The solder joint surfaces are smooth, nonporous and undisturbed, with a finish varying from satin to bright. The fillet completely wets all elements of the connection and is concave.

[NASA-STD-8739.3 \[13.6.1.f.1\]](#)

NASA WORKMANSHIP STANDARDS



**NATIONAL AERONAUTICS AND
SPACE ADMINISTRATION**
JOHNSON SPACE CENTER
HOUSTON, TEXAS USA 77058

Released:
06.27.2002

Revision:

Revision Date:

	Book: 6	Section: 6.01	Page: 1
--	------------	------------------	------------

**THROUGH-HOLE SOLDERING
GENERAL REQUIREMENTS (cont.)**

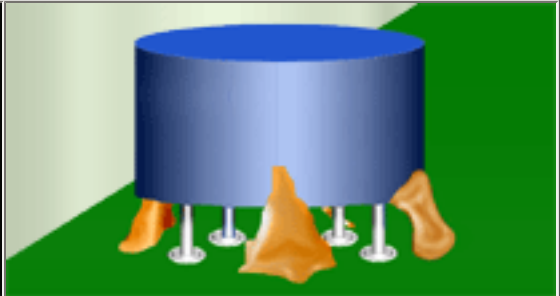
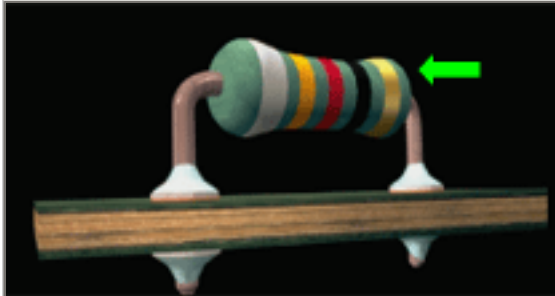

**PREFERRED
HEAT PRODUCING PARTS**

Parts which dissipate heat in quantities of 1 Watt or greater, or in quantities sufficient to damage the laminate shall be mounted with sufficient standoff [$\geq 1.5\text{mm}$ (0.060 in.)] and shall be mechanically restrained.

[Best Workmanship Practice](#)

**PREFERRED
HIGH-MASS COMPONENTS**

Components weighing in excess of 7 g (0.25 oz.) total, or 3.5 gm (0.12 oz.) per lead, shall be mechanically secured to the mounting surface by at least 4 evenly spaced bonds, when no other mechanical support is used.

[Best Workmanship Practice](#)

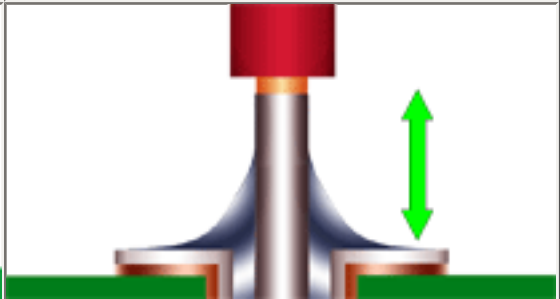
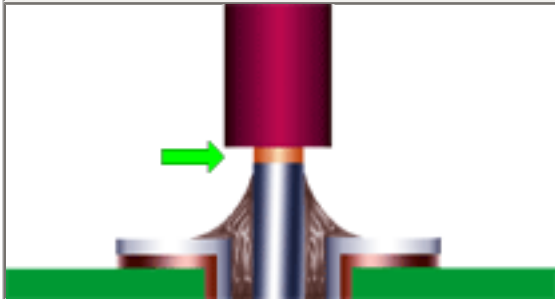

**PREFERRED
WIRE/LEAD INSULATION GAP
(MINIMUM)**

The insulation shall not be imbedded in the solder joint. The contour of the conductor shall not be obscured at the termination end of the insulation.

[NASA-STD-8739.3 \[9.1.1\]](#)

**PREFERRED
WIRE/LEAD INSULATION GAP
(MAXIMUM)**

The termination exhibits a gap of less than two (2) insulated wire diameters ($<2d$) between the end of the insulation and the first point of contact of the conductor to the termination/pad.

[NASA-STD-8739.3 \[9.1.2\]](#)

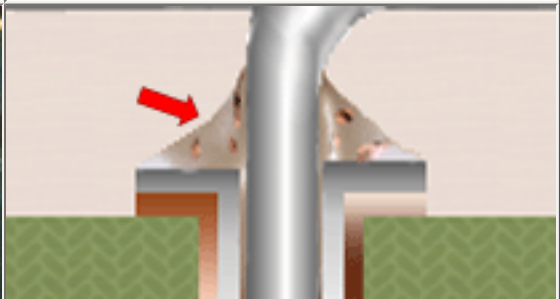
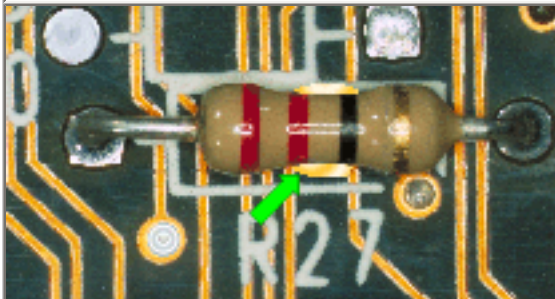

<p>ACCEPTABLE ADHESIVES</p> <p>Adhesives may be used to temporarily hold discrete components in position during wave or reflow soldering. Adhesives shall not interfere with soldering, and residues shall be removed following soldering operations.</p> <p>Best Workmanship Practice</p>	<p>UNACCEPTABLE ADHESIVE INCLUSION</p> <p>Adhesive material in the solder joint shall be cause for rejection.</p> <p>NASA-STD-8739.3 [13.6.2.b.10]</p>
---	---

NASA WORKMANSHIP STANDARDS			
 <p>NATIONAL AERONAUTICS AND SPACE ADMINISTRATION JOHNSON SPACE CENTER HOUSTON, TEXAS USA 77058</p>	Released:	Revision:	Revision Date:
	06.27.2002		
	Book:	Section:	Page:
6	6.01	2	

**THROUGH-HOLE SOLDERING
GENERAL REQUIREMENTS (cont.)**

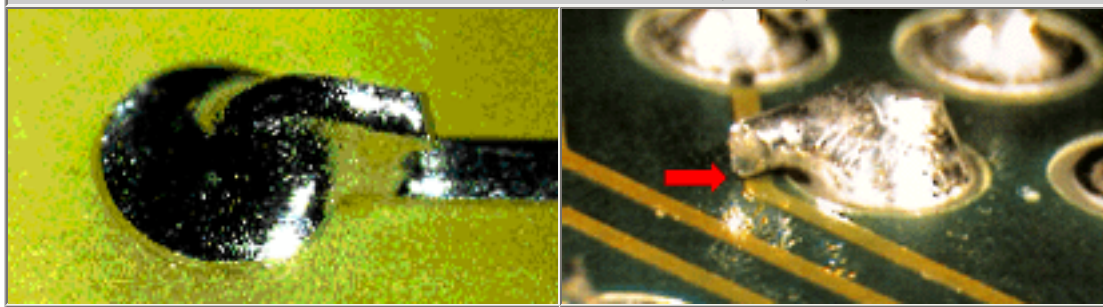

<p>ACCEPTABLE CLINCHED LEAD TERMINATION</p> <p>Conductor/lead ends may be clinched, with the clinched length at least 1/2 the largest solder pad dimension, bent in the direction of the longest pad dimension. Clinched leads shall not violate minimum electrical spacing requirements.</p> <p>NASA-STD-8739.3 [8.5.2]</p>	<p>UNACCEPTABLE IMPROPERLY CLINCHED LEAD</p> <p>Component leads shall not be clinched toward an electrically uncommon conductor.</p> <p>NASA-STD-8739.3 [13.6.2.a.20]</p>
---	--

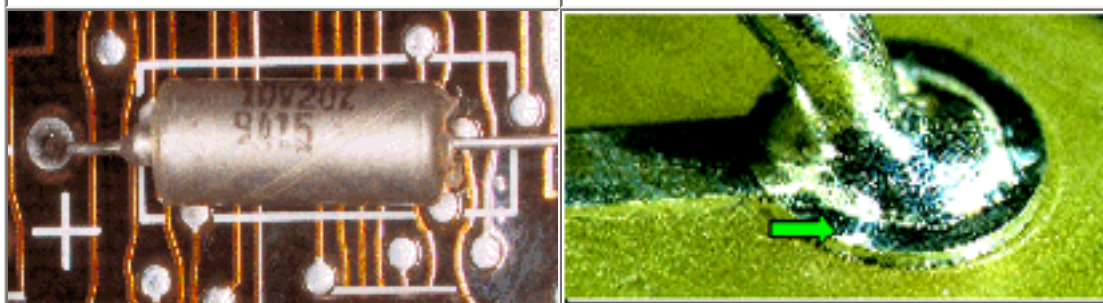

<p>ACCEPTABLE CONDUCTIVE CASE PARTS</p> <p>Parts having conductive cases, which are mounted over printed conductors or which are in close proximity to other conductive materials shall be separated by insulation of suitable thickness, or shall have an insulating jacket/sleeve.</p> <p>NASA-STD-8739.3 [8.1.2.b]</p>	<p>ACCEPTABLE DEWETTING</p> <p>Slight solder dewetting around the periphery of the component side termination pad shall not be cause for rejection, provided the termination exhibits flow-through and bonding of the lead/conductor to the termination pad.</p> <p>NASA-STD-8739.3 [11.2.3.c]</p>
--	---

	
<p style="text-align: center;">ACCEPTABLE EXPOSED BASE METAL</p> <p>Exposed ends of leads on straight-through termination shall not be cause for rejection if the PWA is to be conformally coated.</p> <p>NASA-STD-8739.3 [13.6.1.k]</p>	<p style="text-align: center;">UNACCEPTABLE EXPOSED BASE METAL</p> <p>Defects or damage (cuts, nicks, gouges, scrapes, etc.) that result in exposed base metal (except for the vertical edges of circuit traces, lands and pads) shall be rejectable.</p> <p>NASA-STD-8739.3 [13.6.2.a.8], [13.6.2.c.5]</p>

NASA WORKMANSHIP STANDARDS

 <p>NATIONAL AERONAUTICS AND SPACE ADMINISTRATION JOHNSON SPACE CENTER HOUSTON, TEXAS USA 77058</p>	<p>Released: 06.27.2002</p>	<p>Revision:</p>	<p>Revision Date:</p>
	<p>Book: 6</p>	<p>Section: 6.01</p>	<p>Page: 3</p>

**THROUGH-HOLE SOLDERING
GENERAL REQUIREMENTS (cont.)**

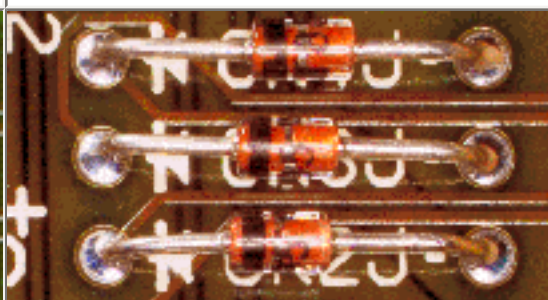
	
<p style="text-align: center;">ACCEPTABLE EXPOSED BASE METAL (SPECIAL EXCEPTION)</p> <p>Exposed base metal on the vertical edge of printed wiring conductors, lands and pads is acceptable.</p> <p>NASA-STD-8739.3 [13.6.2.c.5]</p>	<p style="text-align: center;">ACCEPTABLE FILLER WIRE USE</p> <p>Interfacial connections in double-sided PWBs require the use of filler wire if the PWB coupon is not evaluated by construction analysis.</p> <p>NASA-STD-8739.3 [13.6.2.a.24]</p>
	

<p style="text-align: center;">ACCEPTABLE GLASS ENCASED PARTS</p> <p>Glass encased parts shall be covered with transparent/translucent resilient sleeving (or other approved material) when epoxy is used for staking, conformal coating, encapsulating or where damage from other sources is likely.</p> <p>NASA-STD-8739.3 [8.1.4]</p>	<p style="text-align: center;">UNACCEPTABLE UNSLEEVED GLASS ENCASED PARTS</p> <p>Glass encased parts shall be covered with transparent/translucent resilient sleeving (or other approved material) when epoxy is used for staking, conformal coating, encapsulating or where damage from other sources is likely.</p> <p>NASA-STD-8739.3 [8.1.4], [13.6.2.a.12]</p>
	
<p style="text-align: center;">ACCEPTABLE LEAD PROTRUSION LENGTH</p> <p>Leads terminated straight through the PWB shall extend 0.5 mm (0.020 in.) to 2.29 mm (0.0900 in.) beyond the pad surface. Leads may be bend up to 30° from the vertical plane to retain the part during soldering.</p> <p>NASA-STD-8739.3 [8.5.3]</p>	<p style="text-align: center;">UNACCEPTABLE INSUFFICIENT LEAD PROTRUSION</p> <p>Leads terminated straight through the PWB shall extend a minimum of 0.5 mm (0.020 in.) beyond the pad surface.</p> <p>NASA-STD-8739.3 [13.6.2.a.21]</p>

NASA WORKMANSHIP STANDARDS			
 <p>NATIONAL AERONAUTICS AND SPACE ADMINISTRATION JOHNSON SPACE CENTER HOUSTON, TEXAS USA 77058</p>	Released: 06.27.2002	Revision:	Revision Date:
	Book: 6	Section: 6.01	Page: 4

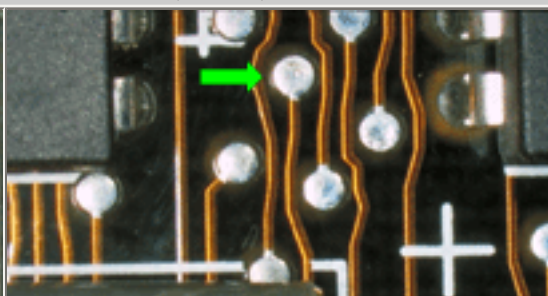
THROUGH-HOLE SOLDERING GENERAL REQUIREMENTS (cont.)	
	
<p style="text-align: center;">ACCEPTABLE INTERFACIAL CONNECTIONS/VIAS (MULTILAYER PWBs)</p> <p>Interfacial connections (vias) in multilayer PWBs do not require the use of filler wire, and shall not be solder filled.</p> <p>NASA-STD-8739.3 [11.2.4.b]</p>	<p style="text-align: center;">ACCEPTABLE SOLDER-FILLED INTERFACIAL CONNECTIONS (PTH/VIAS)</p> <p>No dedicated effort shall be expended to remove solder from unpopulated plated through holes (PTH) and/or vias.</p> <p>NASA-STD-8739.3 [11.2.4]</p>

	
<p style="text-align: center;">ACCEPTABLE MEASLING</p> <p>Whitish, discrete spots or crosses below the laminate surface - usually induced by thermal shock/stress. Measling that bridges uncommon conductors is unacceptable.</p> <p>NASA-STD-8739.3 [13.6.1.I], [13.6.2.c.3]</p>	<p style="text-align: center;">UNACCEPTABLE MEASLING</p> <p>Measling that bridges uncommon conductors is unacceptable.</p> <p>NASA-STD-8739.3 [13.6.2.c.3]</p>
	
<p style="text-align: center;">ACCEPTABLE NON-UNIFORM/UNEVEN FLOW (DEMARICATION LINES/FILLET SWIRLS)</p> <p>A solder fillet exhibiting a nonuniform/ uneven profile, demarcation lines or swirls is acceptable, provided the fillet is shiny and there is evidence of complete wetting with smooth fillets at the swirls.</p> <p>Best Workmanship Practice</p>	<p style="text-align: center;">UNACCEPTABLE UNEVEN FLOW/REFLOW</p> <p>A solder fillet exhibiting nonuniform/ uneven flow lines/ swirls with hard demarcation lines (no fillet at swirl interfaces), and a dull finish are typically caused by an inadequate/uneven application of heat during the fillet formation.</p> <p>Best Workmanship Practice</p>

NASA WORKMANSHIP STANDARDS			
 <p>NATIONAL AERONAUTICS AND SPACE ADMINISTRATION JOHNSON SPACE CENTER HOUSTON, TEXAS USA 77058</p>	Released: 06.27.2002	Revision:	Revision Date:
	Book: 6	Section: 6.01	Page: 5

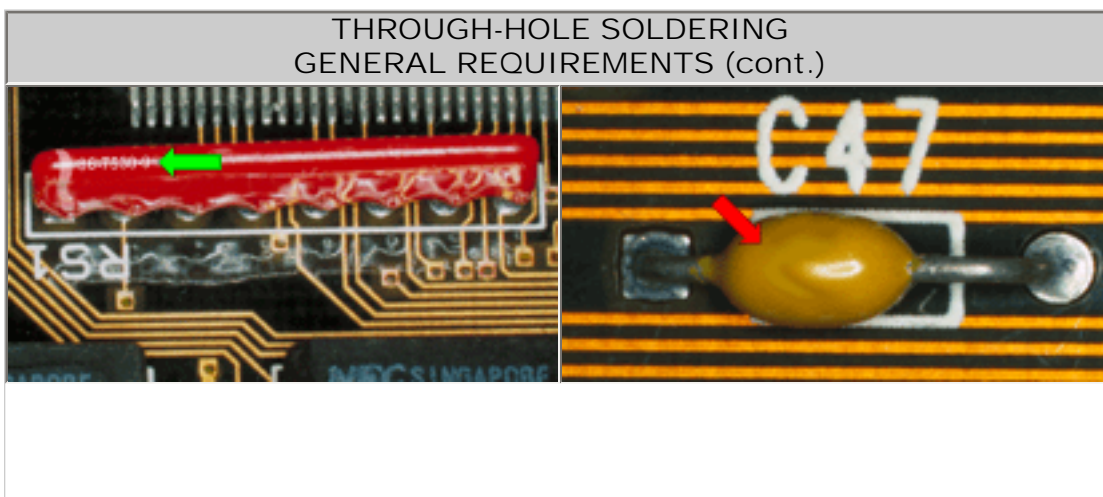

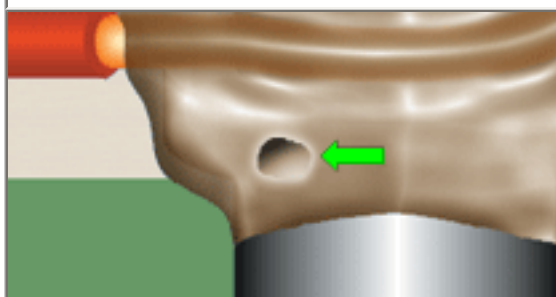
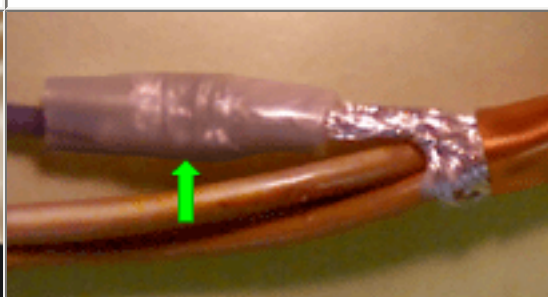
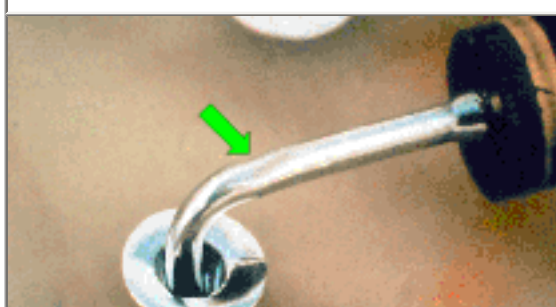
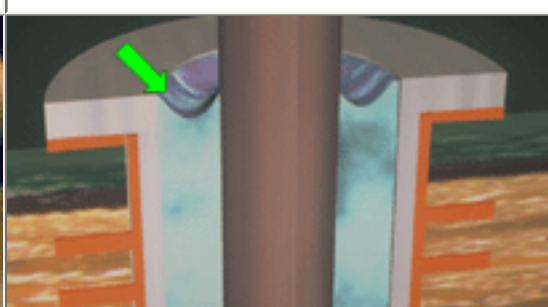
<p style="text-align: center;">ACCEPTABLE PART MARKINGS</p> <p>Parts shall be mounted in such a manner that, at a minimum, the markings are visible in the following order of precedence: polarity, traceability/lot code (if applicable), part value, part number/type.</p> <p>NASA-STD-8739.3 [8.1.3]</p>	<p style="text-align: center;">UNACCEPTABLE IDENTIFICATION MARKS MISSING</p> <p>The component (capacitor C47) has been mounted with the identification marks on the underside of the component body (against the circuit board), preventing visual confirmation that the correct value part is installed.</p> <p>NASA-STD-8739.3 [8.1.3]</p>
	
<p style="text-align: center;">ACCEPTABLE PITS</p> <p>A solder pit is acceptable, provided the bottom of the cavity can be seen from all angles of vision.</p> <p>Best Workmanship Practice</p>	<p style="text-align: center;">ACCEPTABLE SHRINK TUBING (TRANSLUCENT/TRANSPARENT)</p> <p>Shrink tubing installed over components and/or soldered terminations shall be transparent (or translucent) to allow visual inspection.</p> <p>NASA-STD-8739.3 [8.1.4]</p>
	
<p style="text-align: center;">ACCEPTABLE SMOOTH TOOL IMPRESSION MARKS</p> <p>Smooth tool impression marks (slight cuts, nicks, scratch or scrapes) on the conductor surface, which do not expose base metal or reduce cross-sectional area are acceptable.</p> <p>NASA-STD-8739.3 [8.1.6.d]</p>	<p style="text-align: center;">ACCEPTABLE SOLDER FILLET RECESS/SHRINKBACK</p> <p>A slight recessing or shrinkback of the solder into the PTH below the solder pad is acceptable, providing the lead and pad exhibit wetting and the shrinkback is slight.</p> <p>NASA-STD-8739.3 [13.6.1.f.2]</p>

NASA WORKMANSHIP STANDARDS			
 <p>NATIONAL AERONAUTICS AND SPACE ADMINISTRATION JOHNSON SPACE CENTER HOUSTON, TEXAS USA 77058</p>	Released: 06.27.2002	Revision:	Revision Date:
	Book: 6	Section: 6.01	Page: 6

**THROUGH-HOLE SOLDERING
GENERAL REQUIREMENTS (cont.)**

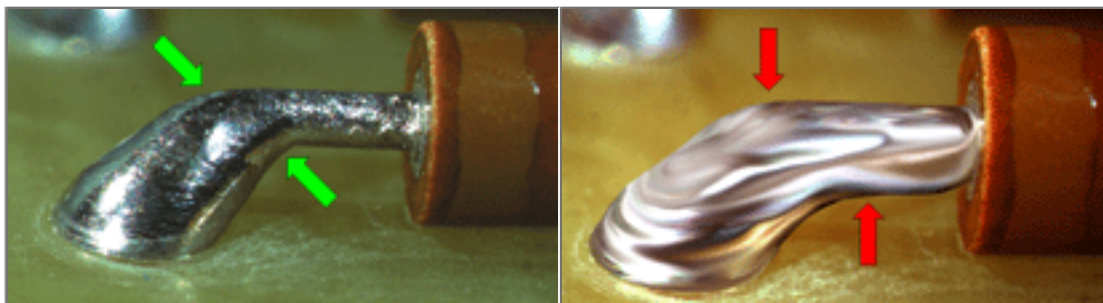

**ACCEPTABLE
SOLDER IN STRESS RELIEF BEND**

Solder which extends into the stress relief bend of any leaded part shall not be cause for rejection if the topside bend radius is discernable, and if the solder does not extend within one (1) lead diameter of the part or end seal.
[NASA-STD-8739.3 \[13.6.2.b.6\]](#)

**UNACCEPTABLE
SOLDER IN STRESS RELIEF BEND**

Solder extends into the stress relief bend and contacts the part body end seal. The topside of the lead is not discernable.
[NASA-STD-8739.3 \[13.6.2.b.6\]](#)

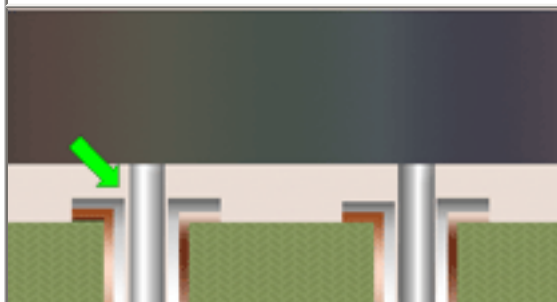

**ACCEPTABLE
TEMPERED LEADS**

Tempered/hardened leads (sometimes referred to as pins) shall not be bent or formed for mounting purposes since body seals and connections internal to the part may be damaged.
[NASA-STD-8739.3 \[8.1.6.e\]](#)

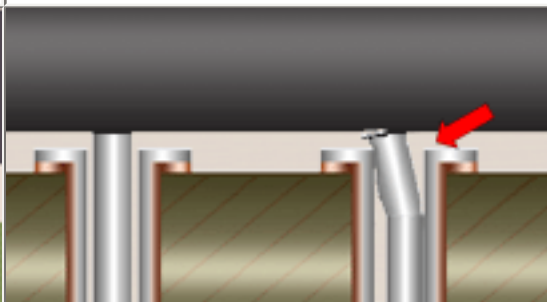

**UNACCEPTABLE
BENT TEMPERED LEADS**

Tempered/hardened leads (sometimes referred to as pins) shall not be bent or formed.
[NASA-STD-8739.3 \[8.1.6.e\]](#)

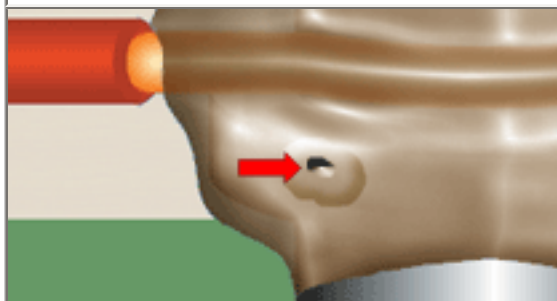

**UNACCEPTABLE
BLOWHOLE**

Blowholes are typically caused by trapped gases or flux during the formation of the solder fillet, and are unacceptable.
[NASA-STD-8739.3 \[13.6.2.b.5\]](#)

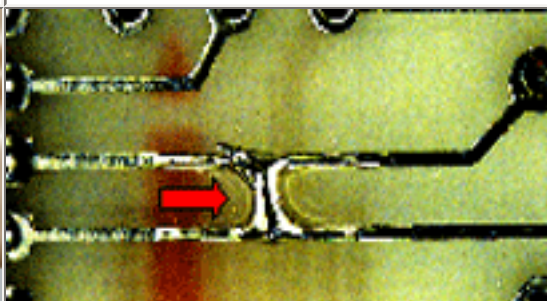

**UNACCEPTABLE
BRIDGING**

Bridging is an indicator of poor process controls (i.e.: excess solder, smeared paste, improper placement, incorrect heat).
[NASA-STD-8739.3 \[13.6.2.c.4\]](#)

NASA WORKMANSHIP STANDARDS			
 <p>NATIONAL AERONAUTICS AND SPACE ADMINISTRATION JOHNSON SPACE CENTER HOUSTON, TEXAS USA 77058</p>	Released: 06.27.2002	Revision:	Revision Date:
	Book: 6	Section: 6.01	Page: 7

THROUGH-HOLE SOLDERING GENERAL REQUIREMENTS (CONT.)		
		
<p style="text-align: center;">UNACCEPTABLE CHARRING</p> <p>Charring of components and/or laminate is an indicator of poor process control (i.e.: excessive heat). NASA-STD-8739.3 [13.6.2.a.7]</p>	<p style="text-align: center;">UNACCEPTABLE CHIP-OUTS (NICKS)</p> <p>The use of parts with chips in the component body, termination area or meniscus, is prohibited. NASA-STD-8739.3 [13.6.2.a.7]</p>	
		
<p style="text-align: center;">UNACCEPTABLE COLD SOLDER JOINT</p> <p>A cold solder joint is an indicator of incorrect process control (i.e.: inadequate heat). NASA-STD-8739.3 [13.6.2.b.1]</p>	<p style="text-align: center;">UNACCEPTABLE CONTAMINATION</p> <p>Contamination is a reliability concern. NASA-STD-8739.3 [13.6.2.b.10]</p>	
		
<p style="text-align: center;">UNACCEPTABLE COPLANARITY</p> <p>Improper coplanarity of leaded parts will result in bridging, shorts, opens and/or misalignment. Part leads shall be reworked (if allowed) prior to installation. NASA-STD-8739.3 [13.6.2.a.5]</p>	<p style="text-align: center;">UNACCEPTABLE CRACKS (COMPONENT)</p> <p>Cracks (especially in ceramic components) are an indicator of poor process control (i.e.: improper preheat, thermal/ mechanical shock, etc.). NASA-STD-8739.3 [13.6.2.a.7]</p>	
NASA WORKMANSHIP STANDARDS		
	Released: 06.27.2002	Revision: Revision Date:



THROUGH-HOLE SOLDERING
 GENERAL REQUIREMENTS (cont.)



UNACCEPTABLE
 CRACKS (LAMINATE)

Cracks in the laminate are cause for rejection.
[Best Workmanship Practice](#)

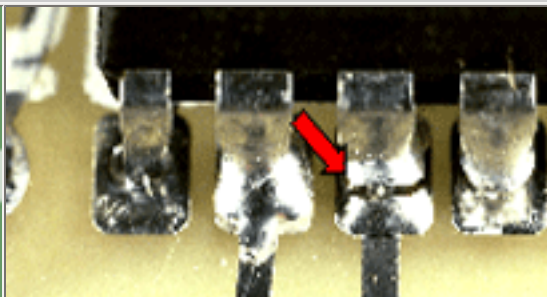

UNACCEPTABLE
 CRACKS (SOLDER FILLET)

Cracks or fractures in the solder fillet are an indication of mechanical/thermal shock, or temperature coefficient mismatch.
[NASA-STD-8739.3 \[13.6.2.b.3\]](#)

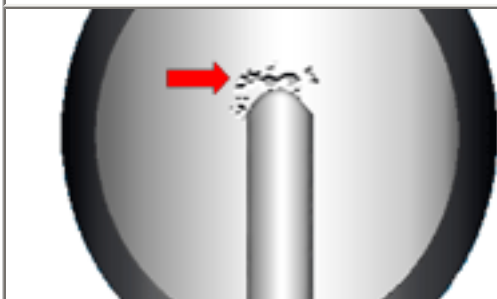

UNACCEPTABLE
 DAMAGED PART SEAL

Parts with damaged seals shall not be used.
[NASA-STD-8739.3 \[13.6.2.a.7\]](#)

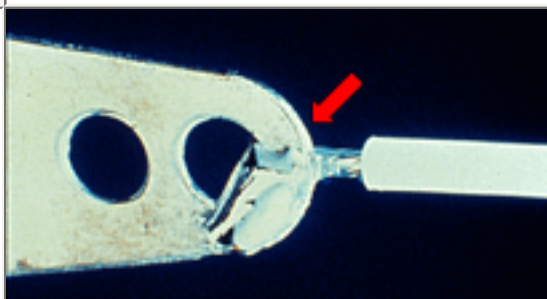

UNACCEPTABLE
 DEWETTING

Dewetting is caused when molten solder coats a surface and then recedes, leaving irregularly-shaped solder deposits separated by areas covered by a thin solder film.
[NASA-STD-8739.3 \[13.6.2.b.11\]](#)

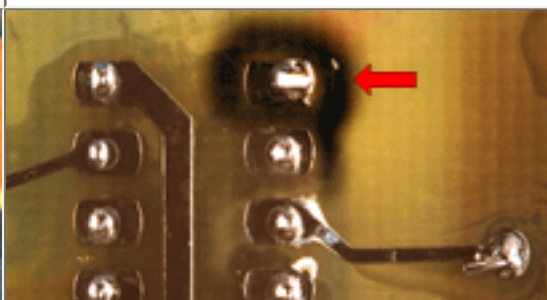





<p style="text-align: center;">UNACCEPTABLE DISCOLORED LAMINATE (BURNS)</p> <p>Burns that physically damage the laminate surface of the assembly are not allowed. Slight discoloration is allowable. NASA-STD-8739.3 [13.6.2.c.2]</p>	<p style="text-align: center;">UNACCEPTABLE DISCOLORED LAMINATE (OVERHEATING)</p> <p>A browning/darkening of the laminate because of excess heat; an indicator of improper process control/ thermal design. NASA-STD-8739.3 [13.6.2.c.3]</p>
--	---

NASA WORKMANSHIP STANDARDS

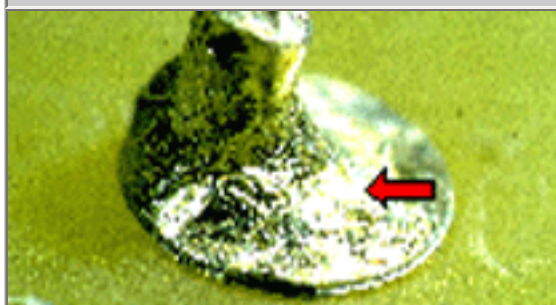
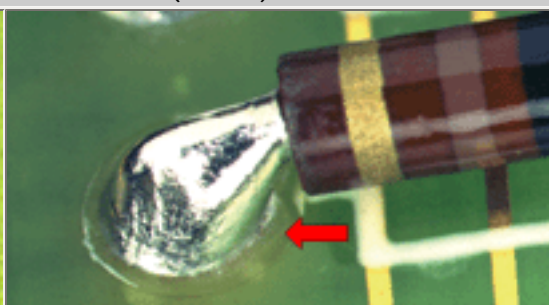
 <p>NATIONAL AERONAUTICS AND SPACE ADMINISTRATION JOHNSON SPACE CENTER HOUSTON, TEXAS USA 77058</p>	<p>Released: 06.27.2002</p>	<p>Revision:</p>	<p>Revision Date:</p>
	<p>Book: 6</p>	<p>Section: 6.01</p>	<p>Page: 9</p>

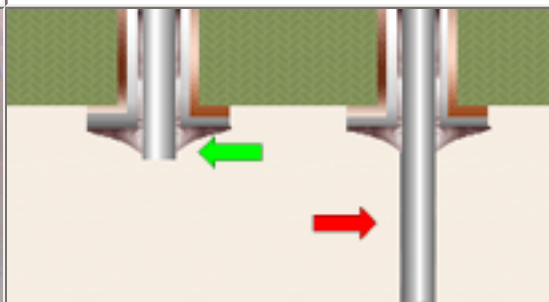
**THROUGH-HOLE SOLDERING
GENERAL REQUIREMENTS (cont.)**

	
<p style="text-align: center;">UNACCEPTABLE DISTURBED SOLDER</p> <p>A disturbed solder joint is characterized by the appearance that there was motion between the metals being joined while the molten solder was solidifying. NASA-STD-8739.3 [13.6.2.b.3]</p>	<p style="text-align: center;">UNACCEPTABLE EXCESS SOLDER</p> <p>The solder fillet shall exhibit a positive wetting angle and shall not contact the component body. NASA-STD-8739.3 [13.6.2.b.6]</p>
	
<p style="text-align: center;">UNACCEPTABLE EXCESS SOLDER/SOLDER FLOODING</p> <p>Excess solder/Solder flooding is an indicator of improper/incorrect process controls, and is typically seen in wave soldering. NASA-STD-8739.3 [13.6.2.b.6]</p>	<p style="text-align: center;">UNACCEPTABLE EXCESSIVE LEAD PROTRUSION</p> <p>Leads terminated straight through the PWB shall extend a maximum of 2.29 mm (0.090 in.) beyond the pad surface. Leads may not violate minimum electrical spacing requirements. NASA-STD-8739.3 [13.6.2.a.21]</p>

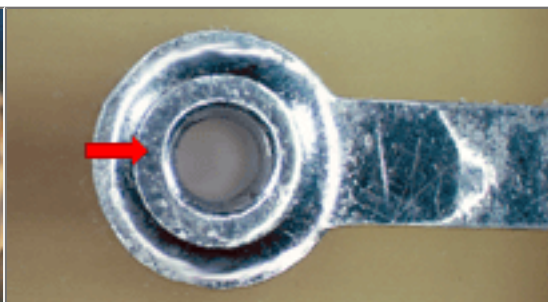
	
<p style="text-align: center;">UNACCEPTABLE EXPOSED DIE/CIRCUIT ELEMENTS</p> <p>The unprotected exposure of die or circuit elements is not allowed unless specified in the engineering documentation. NASA-STD-8739.3 [13.6.2.a.7]</p>	<p style="text-align: center;">UNACCEPTABLE EYELETS</p> <p>Eyelets shall not be used for interfacial terminations. Best Workmanship Practice</p>

NASA WORKMANSHIP STANDARDS				
	<p>NATIONAL AERONAUTICS AND SPACE ADMINISTRATION JOHNSON SPACE CENTER HOUSTON, TEXAS USA 77058</p>	<p>Released: 06.27.2002</p>	<p>Revision:</p>	<p>Revision Date:</p>
		<p>Book: 6</p>	<p>Section: 6.01</p>	<p>Page: 10</p>

THROUGH-HOLE SOLDERING GENERAL REQUIREMENTS (cont.)	
	
<p style="text-align: center;">UNACCEPTABLE FLUX RESIDUE</p> <p>Flux residue indicates improper/ incomplete cleaning. NASA-STD-8739.3 [13.6.2.b.10]</p>	<p style="text-align: center;">UNACCEPTABLE FLUX SPLATTER</p> <p>Flux splatter is an indication of an improper process parameter (heat/moisture). NASA-STD-8739.3 [13.6.2.b.8]</p>
	

<p style="text-align: center;">UNACCEPTABLE FRACTURED SOLDER</p> <p>A fractured solder joint is an indication that the joint has been subjected to extreme mechanical shock. A crack in an "as-received" assembly is unusual and cause for concern.</p> <p>NASA-STD-8739.3 [13.6.2.b.3]</p>	<p style="text-align: center;">UNACCEPTABLE GOLD INTERMETALLIC</p> <p>Gold intermetallic is characterized by evidence of golden colored streaks in the solder fillets of gold plated leads that have not been properly tinned. Gold intermetallic can severely embrittle a solder joint.</p> <p>Best Workmanship Practice</p>
	
<p style="text-align: center;">UNACCEPTABLE GOLD PLATING</p> <p>Gold plated surfaces that will become part of the finished solder connection shall be tinned prior to soldering to remove the gold plating.</p> <p>NASA-STD-8739.3 [7.2.5.c],[13.6.2.a.3]</p>	<p style="text-align: center;">UNACCEPTABLE HOLE OBSTRUCTION</p> <p>The mounting pad has been installed upside down. Parts shall not be mounted such that they obstruct solder flow to the component-side termination area (pad) or prevent cleaning and inspection.</p> <p>NASA-STD-8739.3 [8.4.4]</p>

NASA WORKMANSHIP STANDARDS			
 <p>NATIONAL AERONAUTICS AND SPACE ADMINISTRATION JOHNSON SPACE CENTER HOUSTON, TEXAS USA 77058</p>	Released: 06.27.2002	Revision:	Revision Date:
	Book: 6	Section: 6.01	Page: 11

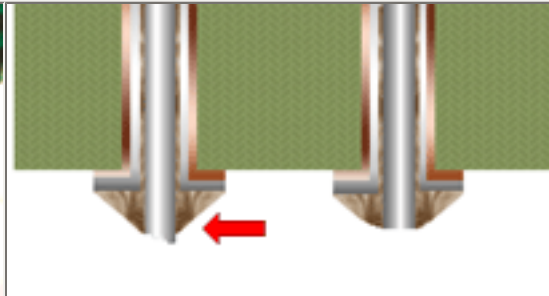
THROUGH-HOLE SOLDERING GENERAL REQUIREMENTS (cont.)	
	
<p style="text-align: center;">UNACCEPTABLE IMPROPER LEAD BENDING</p> <p>The minimum distance from the part body/seal to the start of the bend shall be 2 lead diameters for round leads and 0.5 mm (0.020) for ribbon leads. The bend radius shall not be less than one lead diameter (1 d) or ribbon thickness (1 t).</p> <p>NASA-STD-8739.3 [8.1.6.a]</p>	<p style="text-align: center;">UNACCEPTABLE IMPROPER LEAD CUTTING</p> <p>Leads shall be cut per engineering documentation and by methods, which do not impart stress to the lead seal or internal terminations.</p> <p>NASA-STD-8739.3 [8.1.6.a]</p>

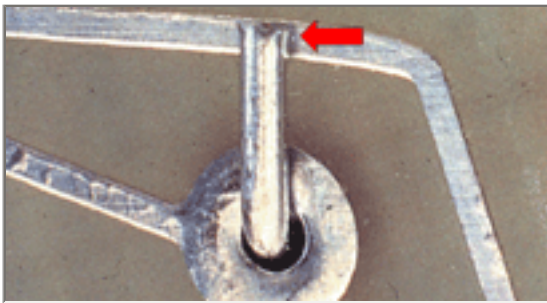

**UNACCEPTABLE
IMPROPER LEAD LENGTH**

The clinched lead extends beyond the pad edge in excess of allowed limits and is bent over an uncommon electrical conductor.

[NASA-STD-8739.3 \[13.6.2.a.20\]](#)

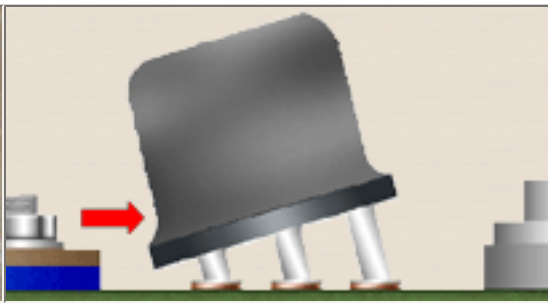

**UNACCEPTABLE
IMPROPER ORIENTATION**

Parts shall be mounted parallel to the laminate surface, right side up and aligned to the lands within design and engineering specifications.

[NASA-STD-8739.3 \[13.6.2.a.5\]](#)

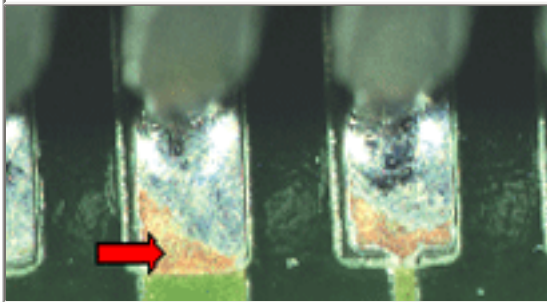

**UNACCEPTABLE
IMPROPER TINNING**

Tinned surfaces, which are to become part of the solder termination, shall exhibit 100% coverage.

[NASA-STD-8739.3 \[7.2.6\],\[13.6.2.a.3\]](#)

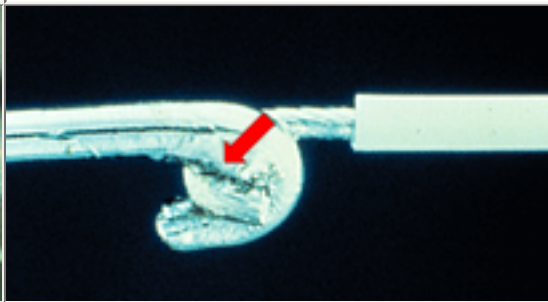

**UNACCEPTABLE
INSUFFICIENT SOLDER**

Insufficient solder is an indicator of improper process control, and may result in reduced reliability.

[NASA-STD-8739.3 \[13.6.2.b.7\]](#)

NASA WORKMANSHIP STANDARDS



**NATIONAL AERONAUTICS AND
SPACE ADMINISTRATION**
JOHNSON SPACE CENTER
HOUSTON, TEXAS USA 77058

Released:
06.27.2002

Revision:

Revision Date:

Book:
6

Section:
6.01

Page:
12

**THROUGH-HOLE SOLDERING
GENERAL REQUIREMENTS (cont.)**

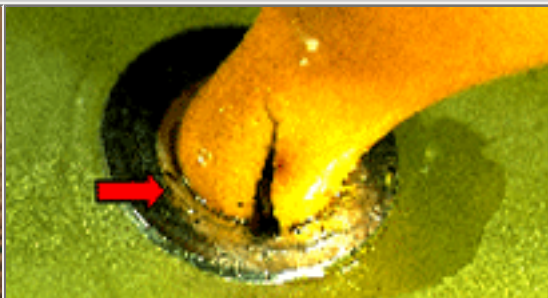

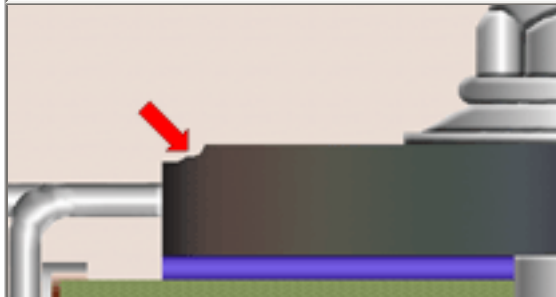
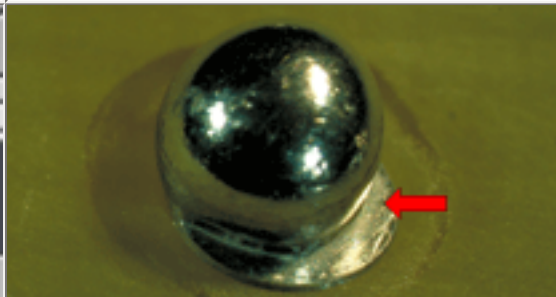
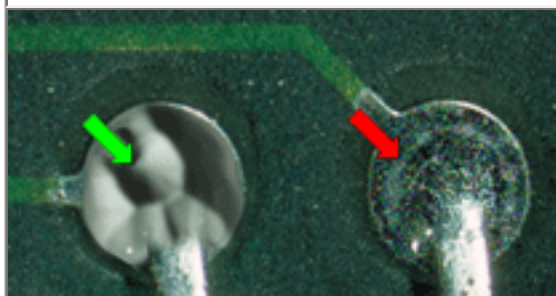
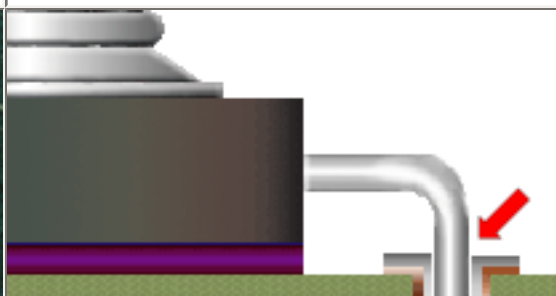
<p style="text-align: center;">UNACCEPTABLE INSUFFICIENT STRESS RELIEF/LEAD BEND</p> <p>Lead is improperly bent, placing strain on the weld bead. Conductors and part leads shall have sufficient stress relief to prevent damage to the solder termination and/or part. NASA-STD-8739.3 [13.6.2.a.10]</p>	<p style="text-align: center;">UNACCEPTABLE MENISCUS CONTACT</p> <p>Parts exhibiting contact with, or embedment of the meniscus and the solder joint, shall be rejected. NASA-STD-8739.3 [8.1.7], [13.6.2.b.13]</p>
	
<p style="text-align: center;">UNACCEPTABLE NICKS</p> <p>The use of parts with nicks in the component body or termination area is prohibited. NASA-STD-8739.3 [13.6.2.a.7]</p>	<p style="text-align: center;">UNACCEPTABLE NONWETTING</p> <p>Nonwetting results in the solder forming a ball or beading on the termination surface. The fillet is convex; no feathered edge is apparent. NASA-STD-8739.3 [13.6.2.b.12]</p>
	
<p style="text-align: center;">UNACCEPTABLE NO FLOW/REFLOW</p> <p>The lack of flow/reflow of solder is an indicator of poor process control or layout design (i.e.: inadequate heat, shadowing). NASA-STD-8739.3 [13.6.2.b.1]</p>	<p style="text-align: center;">UNACCEPTABLE NO SOLDER</p> <p>The lack of solder is an indicator of poor process control. NASA-STD-8739.3 [13.6.2.b.7]</p>

NASA WORKMANSHIP STANDARDS

 <p>NATIONAL AERONAUTICS AND SPACE ADMINISTRATION JOHNSON SPACE CENTER HOUSTON, TEXAS USA 77058</p>	Released: 06.27.2002	Revision:	Revision Date:
	Book: 6	Section: 6.01	Page: 13

**THROUGH-HOLE SOLDERING
GENERAL REQUIREMENTS (cont.)**

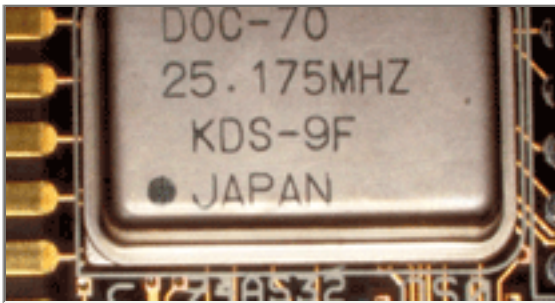

UNACCEPTABLE
OBSCURED SOLDER TERMINATIONS

The placement of a part, which obscures the inspectability of another part's terminations, is unacceptable, unless interim inspection is performed (part depicted is mounted over previously installed surface mount components).

[NASA-STD-8739.3 \[13.6.2.a.23\]](#)

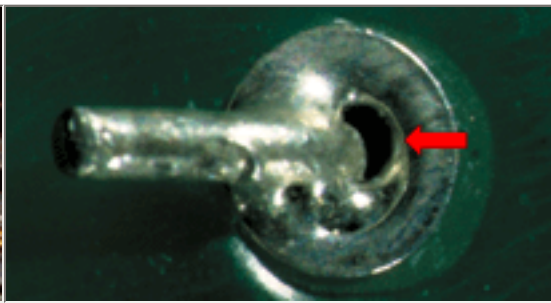

UNACCEPTABLE
OPENS/VOIDS

Cavities (opens/voids) reduce the circumferential wetting of lead and barrel, land coverage and vertical solder fill below minimum acceptable requirements.

[NASA-STD-8739.3 \[13.6.2.b.5\]](#)

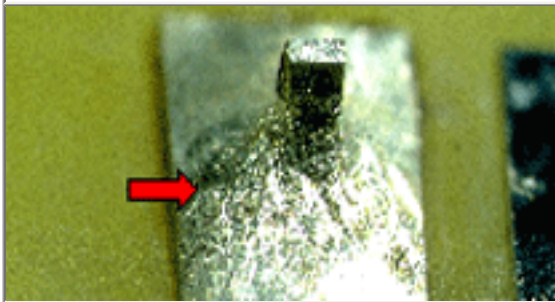

UNACCEPTABLE
OVERHEATED SOLDER

Overheated solder has a dull, gray, frosty and/or crystallized appearance and is the result of excessive exposure to heat.

[NASA-STD-8739.3 \[13.6.2.b.2\]](#)

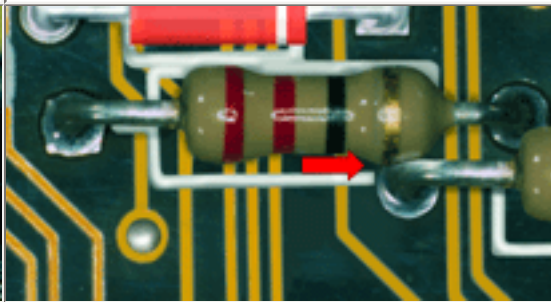

UNACCEPTABLE
PART BODY CONTACT

Part bodies shall not be in contact with soldered terminations. The spacing between components is below recommended values, resulting in contact between the resistor body and the lead, which may eventually result in a short circuit.

[NASA-STD-8739.3 \[8.1.7\], \[13.6.2.b.13\]](#)



UNACCEPTABLE
PART LEADS USED AS TERMINALS

Part leads shall not be used as terminals, unless the part lead is designed to function as a terminal.

[NASA-STD-8739.3 \[13.6.2.a.18\]](#)

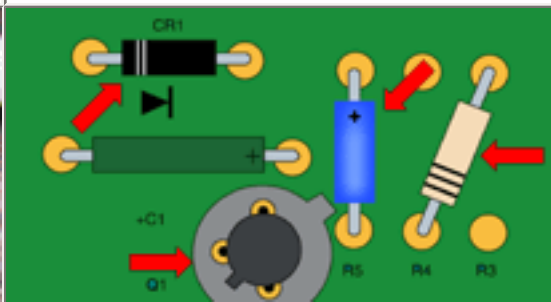

UNACCEPTABLE
PART MISALIGNMENT

Part misalignment is an indicator of improper process control.

[NASA-STD-8739.3 \[13.6.2.a.5\]](#)

NASA WORKMANSHIP STANDARDS



NATIONAL AERONAUTICS AND SPACE ADMINISTRATION
JOHNSON SPACE CENTER
HOUSTON, TEXAS USA 77058

Released:
06.27.2002

Revision:

Revision Date:

Book:
6

Section:
6.01

Page:
14

THROUGH-HOLE SOLDERING
GENERAL REQUIREMENTS (cont.)

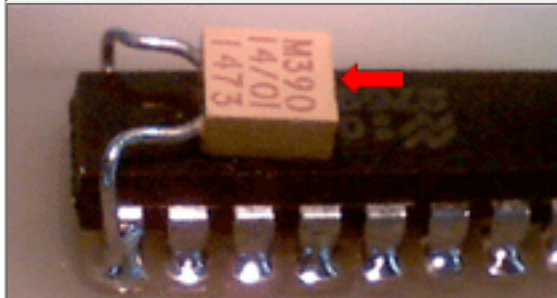

UNACCEPTABLE
PIGGYBACKED PARTS

The piggybacking of parts not designed specifically for that configuration is prohibited.

[Best Workmanship Practice](#)

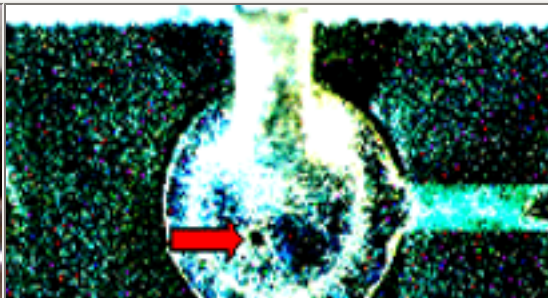

UNACCEPTABLE
PINHOLE

Pinholes are typically small holes in the solder surface, leading to a void of indeterminate size within the solder termination.

[NASA-STD-8739.3 \[13.6.2.b.5\]](#)

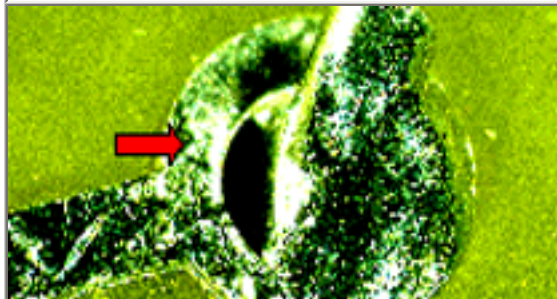

UNACCEPTABLE
POOR WETTING

Poor wetting is an indicator of poor solderability, improper flux or contamination.

[NASA-STD-8739.3 \[13.6.2.b.4\]](#)

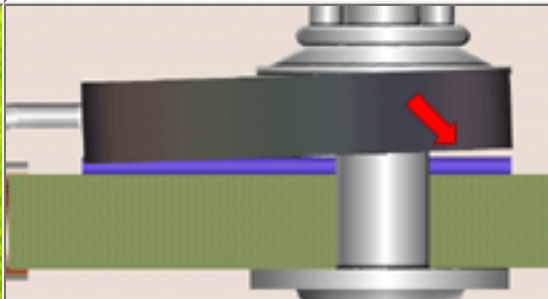

UNACCEPTABLE
POPCORNING

Popcorning is caused by the release of entrapped moisture during the soldering process.

[Best Workmanship Practice](#)



UNACCEPTABLE
POROUS SOLDER

Porous solder exhibits an uneven surface and a spongy appearance that may contain a concentration of small pinholes and voids.

[Best Workmanship Practice](#)

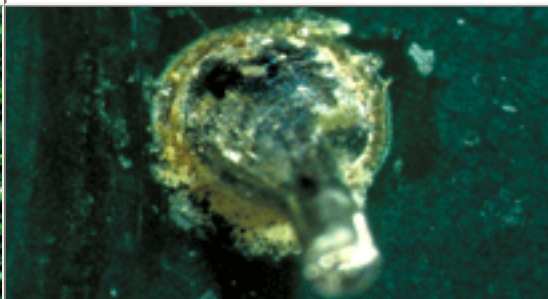

UNACCEPTABLE
ROSIN SOLDER JOINT

A rosin solder joint is similar in appearance to a cold solder joint, but exhibits evidence of entrapped flux in the fillet and at the surfaces to be joined.

[NASA-STD-8739.3 \[13.6.2.b.9\]](#)

NASA WORKMANSHIP STANDARDS

Released:
06.27.2002

Revision:

Revision Date:



THROUGH-HOLE SOLDERING
 GENERAL REQUIREMENTS (cont.)

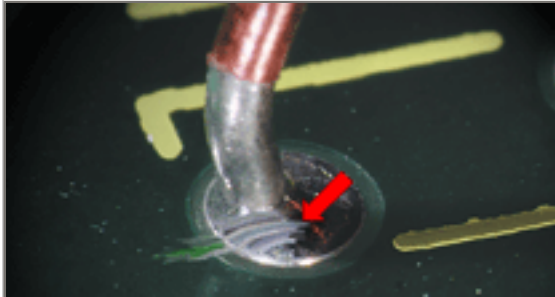

UNACCEPTABLE
 SCRATCHES (SOLDER FILLET)

Scratches in the solder are prohibited.
[NASA-STD-8739.3 \[13.6.2.b.3\]](#)

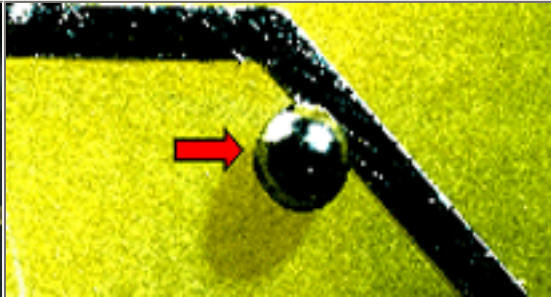

UNACCEPTABLE
 SOLDER BALLS

Solder balls are considered a contaminant and are an indication of improper process control (inadequate preheat) and/or the use of outdated solder/flux.
[NASA-STD-8739.3 \[13.6.2.b.10\]](#)

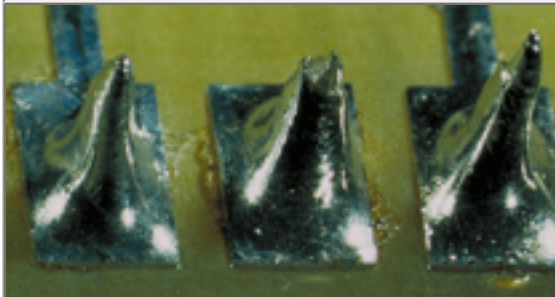

UNACCEPTABLE
 SOLDER PEAKS, ICICLES, SHARP EDGES

Solder peaks, icicles and/or sharp edges are an indicator of an improper process parameter and are a reliability and short-circuit concern.
[NASA-STD-8739.3 \[13.6.2.c.4\]](#)

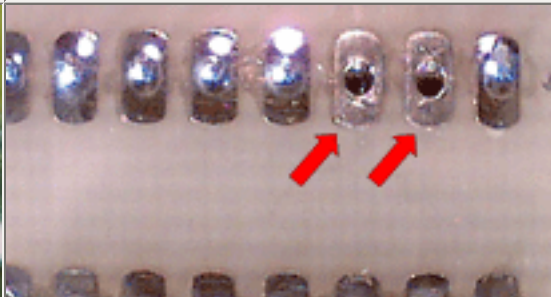

UNACCEPTABLE
 SOLDER SKIPS

Solder skip is the random non-formation of solder fillets, and is an indicator of poor process control. Solder skip may be caused by insufficient solder, contamination, non-solderability (oxide), improper flux, solder thieving, etc.
[NASA-STD-8739.3 \[13.6.2.b.7\]](#)

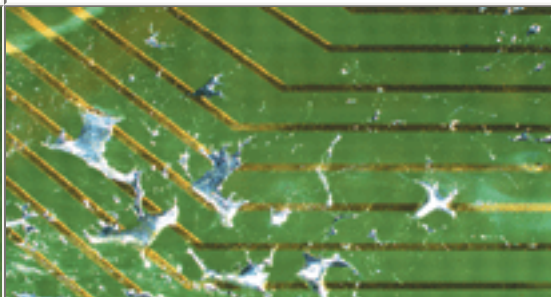
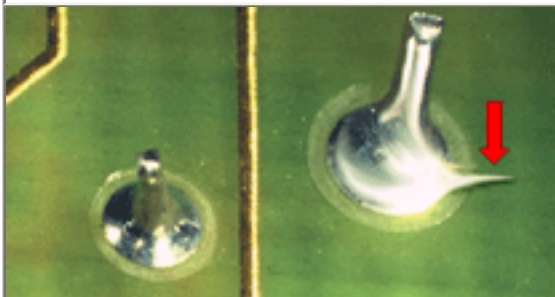

<p>UNACCEPTABLE SOLDER SLIVERS</p> <p>Solder slivers are an indication of improper process control.</p> <p>NASA-STD-8739.3 [13.6.2.c.4]</p>	<p>UNACCEPTABLE SOLDER SPLATTER</p> <p>Solder splatter is typically caused by moisture contamination and is an indicator of poor process control.</p> <p>NASA-STD-8739.3 [13.6.2.b.8]</p>
--	--

NASA WORKMANSHIP STANDARDS			
 <p>NATIONAL AERONAUTICS AND SPACE ADMINISTRATION JOHNSON SPACE CENTER HOUSTON, TEXAS USA 77058</p>	Released:	Revision:	Revision Date:
	06.27.2002		
	Book:	Section:	Page:
6	6.01	16	

THROUGH-HOLE SOLDERING GENERAL REQUIREMENTS (cont.)	
	
<p>UNACCEPTABLE SOLDER WEBBING</p> <p>Webbing is an indication of improper process control.</p> <p>NASA-STD-8739.3 [13.6.2.c.4]</p>	<p>UNACCEPTABLE SPliced CONDUCTORS/LEADS</p> <p>Splices shall not be used to repair broken or damaged conductors or part leads.</p> <p>NASA-STD-8739.3 [8.1.8], [13.6.2.a.16]</p>
	
<p>UNACCEPTABLE VOIDS</p> <p>Voids are an indication of improper process control, and are typically caused by insufficient solder, solder wicking/stealing or contamination.</p> <p>NASA-STD-8739.3 [13.6.2.b.5]</p>	<p>UNACCEPTABLE WHISKER</p> <p>A whisker is a slender needle-shaped metallic growth between a conductor and a land. Typically the result of mechanical stresses in high tin compounds, it is a reliability concern.</p> <p>Best Workmanship Practice</p>

NASA WORKMANSHIP STANDARDS			
 NATIONAL AERONAUTICS AND SPACE ADMINISTRATION JOHNSON SPACE CENTER HOUSTON, TEXAS USA 77058	Released: 06.27.2002	Revision:	Revision Date:
	Book: 6	Section: 6.01	Page: 17



[Need a printed copy?](#)
(May take a while to load.)
Requires Adobe Reader.



[Need Adobe Reader?](#)
[Click here to download.](#)



[Questions? Suggestions?](#)

THROUGH-HOLE SOLDERING
PREPARATION OF CONDUCTORS

PREPARATION OF CONDUCTORS

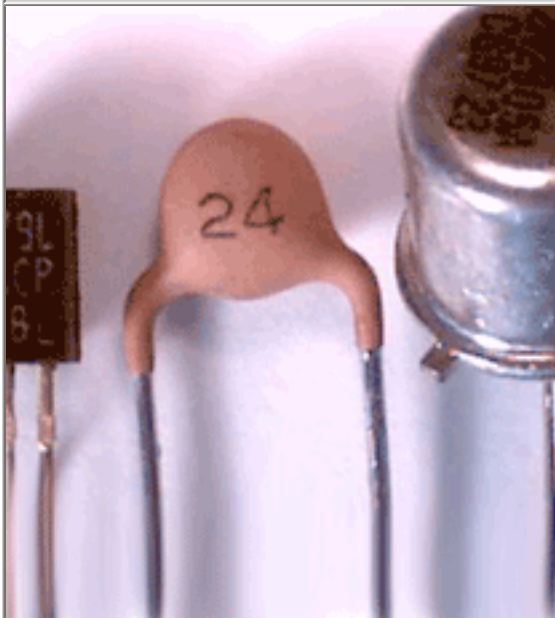

The quality of solder terminations can be correlated to the preparation of the conductors prior to soldering.

Solderability can be significantly improved by the pre-tinning and thorough cleaning of all surfaces designated to be part of the completed solder termination. Pre-forming of component leads and other conductors reduces stresses in the solder joint and component body.

See Section 6.01 "Through-Hole Soldering, General Requirements", for common accept/reject criteria.

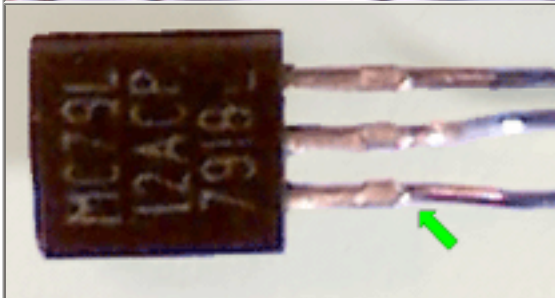

PREFERRED
COMPONENT LEADS

The component's leads have been tinned, formed and cleaned per engineering requirements. Gold plating has been removed. The spacing and radius of bends are within requirements. There is no mechanical damage to the component leads or body.

PREFERRED
CONDUCTORS/WIRE

The conductors have been stripped, tinned, formed and cleaned per engineering requirements. There is no mechanical damage to the conductor or insulation, no reduced cross-section and individual strands are discernable.

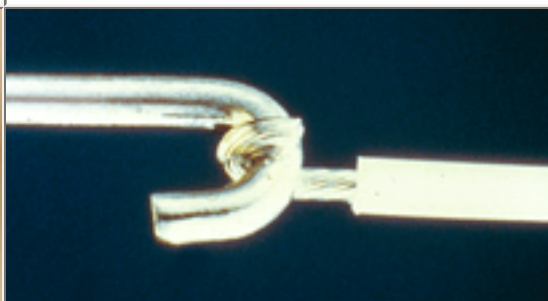

PREFERRED
TERMINATION AREAS/PWB

Termination areas have been tinned with hot-coated tin-lead solder or hot reflowed electro-deposited tin-lead solder prior to mounting of the parts. Gold plating has been removed.

PREFERRED
TERMINATIONS/MISCELLANEOUS

The terminations have been properly tinned, formed and cleaned in preparation of solder termination. The preparation of simple terminations, such as the hook and conductor termination shown, is just as important as more complex terminations.

NASA WORKMANSHIP STANDARDS

Released:
06.27.2002

Revision:

Revision Date:



THROUGH-HOLE SOLDERING PREPARATION OF CONDUCTORS (cont.)	
<p>PREFERRED COMPONENT CENTERING</p> <p>The component leads shall be bent such that the distance from the bend to the end seal shall be approximately equal at each end of the part, resulting in the centering of the part between the mounting holes.</p> <p>NASA-STD-8739.3 [8.1.6.a]</p>	<p>UNACCEPTABLE IMPROPER CENTERING</p> <p>The component leads shall be bent such that the distance from the bend to the end seal shall be approximately equal at each end of the part, resulting in the centering of the part between the mounting holes.</p> <p>NASA-STD-8739.3 [8.1.6.a], [13.6.2.a.5]</p>
<p>ACCEPTABLE LEAD FORMING-BEND RADIUS</p> <p>The radius of bends in the conductor shall not be less than the lead diameter or lead thickness.</p> <p>NASA-STD-8739.3 [8.1.6.a]</p>	<p>UNACCEPTABLE IMPROPER BEND RADIUS</p> <p>The radius of bends in the conductor shall not be less than the lead diameter or lead thickness.</p> <p>NASA-STD-8739.3 [8.1.6.a], [13.6.2.a.10]</p>

<p>ACCEPTABLE LEAD FORMING-BEND SPACING</p> <p>The minimum distance from the part body or seal to the start of the bend in a part lead shall be a minimum of 2 lead diameters for round leads, and 0.5 mm (0.020 in.) for ribbon leads.</p> <p>NASA-STD-8739.3 [8.1.6.a]</p>	<p>UNACCEPTABLE IMPROPER LEAD/BEND SPACING</p> <p>The minimum distance from the part body, seal or weld bead to the start of the bend in a part lead shall be a minimum of 2 lead diameters for round leads, and 0.5 mm (0.020 in.) for ribbon leads.</p> <p>NASA-STD-8739.3 [8.1.6.a], [13.6.2.a.15]</p>
---	--

NASA WORKMANSHIP STANDARDS			
 <p>NATIONAL AERONAUTICS AND SPACE ADMINISTRATION JOHNSON SPACE CENTER HOUSTON, TEXAS USA 77058</p>	Released:	Revision:	Revision Date:
	06.27.2002		
	Book:	Section:	Page:
6	6.02	2	

**THROUGH-HOLE SOLDERING
PREPARATION OF CONDUCTORS (cont.)**

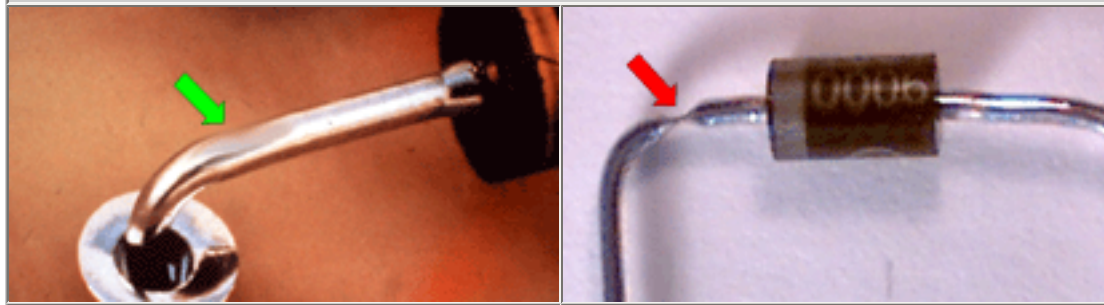

<p>ACCEPTABLE LEAD FORMING-SMOOTH TOOL MARKS</p> <p>Smooth tool impression marks resulting from tool holding forces are acceptable, provided they do not expose base metal or reduce cross-sectional area.</p> <p>NASA-STD-8739.3 [7.2.3], [8.1.6.d]</p>	<p>UNACCEPTABLE REDUCED CROSS-SECTIONAL AREA</p> <p>Part leads and other conductors that have deformation/damage resulting in a reduced cross-sectional area shall not be used.</p> <p>NASA-STD-8739.3 [7.2.3], [8.1.6.d] NASA-STD-8739.4 [10.1.3]</p>
---	---

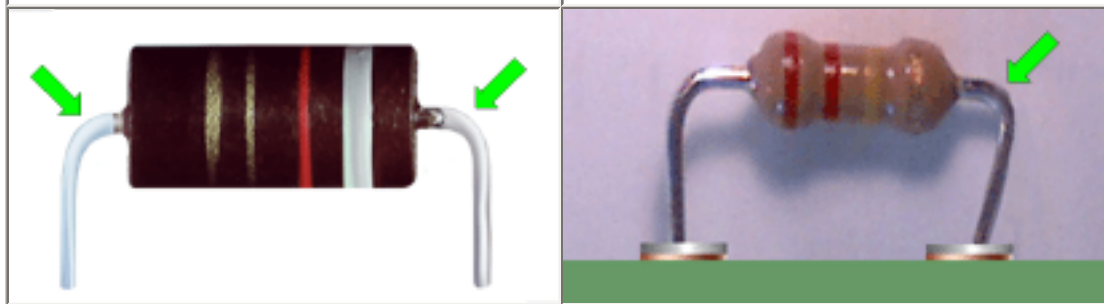

<p>ACCEPTABLE PREFORMING/SIZING</p> <p>Part leads shall be formed so that they may be installed into the holes in the PWB without excessive deformation that can stress the part body or end seals. All leads should be tinned and formed prior to mounting.</p> <p>NASA-STD-8739.3 [8.1.6.b], [8.1.6.c]</p>	<p>UNACCEPTABLE IMPROPER PREFORMING/SIZING</p> <p>Part leads shall be formed so that they may be installed into the holes in the PWB without excessive deformation that can stress the part body or end seals.</p> <p>NASA-STD-8739.3 [8.1.6.b], [8.1.6.c]</p>
---	---

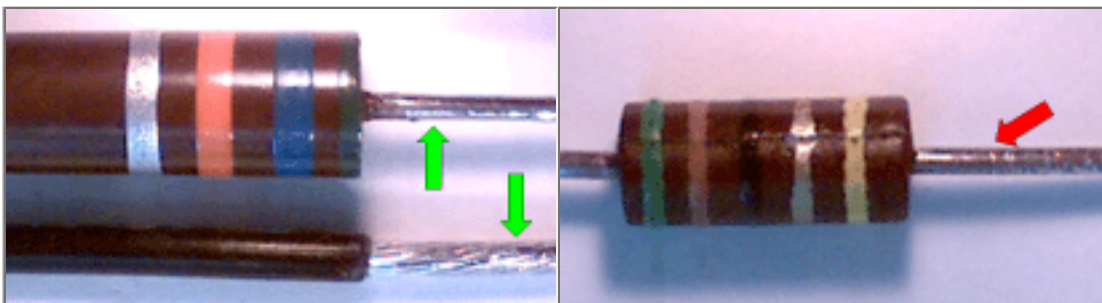

**ACCEPTABLE
TINNING-COVERAGE**

The portion of stranded or solid conductors, or part leads shall be solder tinned and cleaned prior to attachment. The solder shall completely wet the conductor and exhibit 100% coverage.

[NASA-STD-8739.3 \[7.2.5\], \[7.2.6\]](#)
[NASA-STD-8739.4 \[10.1.5\]](#)

**UNACCEPTABLE
IMPROPER TINNING (COVERAGE)**

The solder shall completely wet the conductor and shall exhibit 100% coverage.

[NASA-STD-8739.3 \[7.2.5\], \[7.2.6\], \[13.6.2.a.3\]](#)
[NASA-STD-8739.4 \[10.1.5\]](#)

NASA WORKMANSHIP STANDARDS



**NATIONAL AERONAUTICS AND
SPACE ADMINISTRATION**
**JOHNSON SPACE CENTER
HOUSTON, TEXAS USA 77058**

Released:
06.27.2002

Revision:

Revision Date:

Book:
6

Section:
6.02

Page:
3

**THROUGH-HOLE SOLDERING
PREPARATION OF CONDUCTORS (cont.)**



**ACCEPTABLE
TINNING-DIMENSIONS**

Hot tinning of solid conductors and part leads shall not extend closer than 0.5 mm (0.020 in.) to part bodies, end seals or insulation, unless the part configuration and mounting configuration dictate.

[NASA-STD-8739.3 \[7.2.5.a\]](#)





**UNACCEPTABLE
IMPROPER TINNING (SPACING)**

The tinning has extended closer than 0.5 mm (0.020 in.) to the part body/lead seals, and may have compromised the hermetic seal.

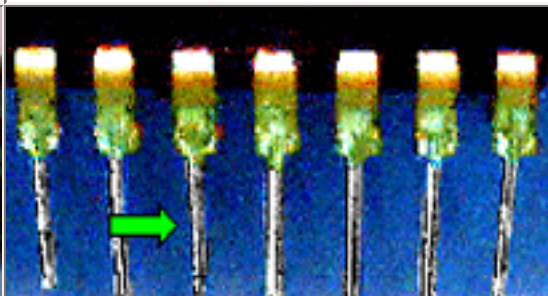
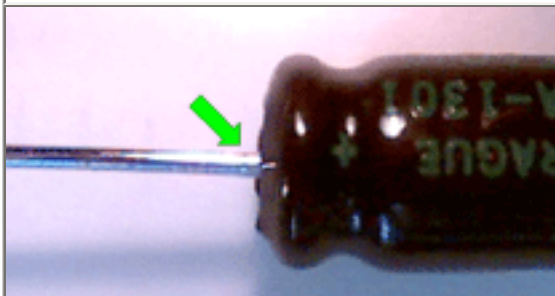
[NASA-STD-8739.3 \[7.2.5.a\], \[13.6.2.a.3\]](#)

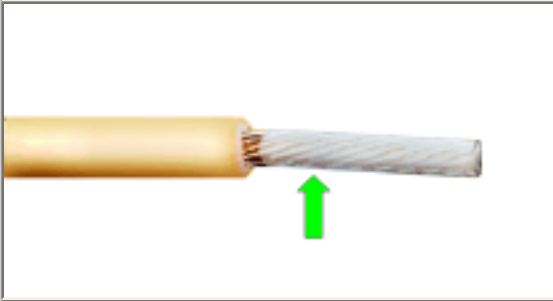
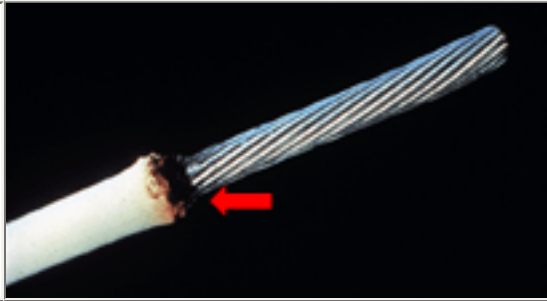

<p style="text-align: center;">ACCEPTABLE TINNING-DIMENSIONS (SPECIAL EXEMPTION)</p> <p>In instances where conductor tinning is required to be closer than 0.5 mm (0.20 in.), the part body, end seals, or insulation shall be inspected for damage and results recorded.</p> <p>NASA-STD-8739.3 [7.2.5.a]</p>	<p style="text-align: center;">ACCEPTABLE TINNING-GOLD REMOVAL</p> <p>Gold plating on all surfaces that become part of finished solder connection shall be removed by two successive tinning operations, or by other approved processes.</p> <p>NASA-STD-8739.3 [7.2.5.c]</p>
	
<p style="text-align: center;">ACCEPTABLE TINNING-STRANDED WIRE</p> <p>The solder shall completely wet the conductor, penetrate to the inner strands, and exhibit 100% coverage. Wire strands shall be distinguishable. Wicking of flux or solder shall be minimized.</p> <p>NASA-STD-8739.3 [7.2.5], [7.2.6] NASA-STD-8739.4 [10.1.5]</p>	<p style="text-align: center;">UNACCEPTABLE DAMAGED INSULATION</p> <p>After stripping and tinning, the conductor insulation shall not exhibit any damage, such as nicks, cuts or charring. Conductors with damaged insulation shall not be used.</p> <p>NASA-STD-8739.3 [13.6.2.a.1] NASA-STD-8739.4 [19.6.2.a.2]</p>

NASA WORKMANSHIP STANDARDS			
 <p>NATIONAL AERONAUTICS AND SPACE ADMINISTRATION JOHNSON SPACE CENTER HOUSTON, TEXAS USA 77058</p>	Released: 06.27.2002	Revision:	Revision Date:
	Book: 6	Section: 6.02	Page: 4

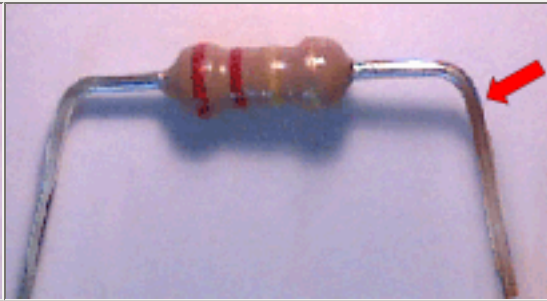
THROUGH-HOLE SOLDERING PREPARATION OF CONDUCTORS (cont.)	
	
<p style="text-align: center;">ACCEPTABLE TINNING-TERMINALS/SOLDER CUPS</p> <p>Terminals and solder cups shall be solder tinned, examined for damage, and cleaned prior to the attachment of conductors.</p> <p>NASA-STD-8739.3 [7.2.5], [7.3.1], [7.3.2]</p>	<p style="text-align: center;">UNACCEPTABLE DAMAGED CONDUCTOR-GENERAL</p> <p>After removal of the conductor insulation and/or lead forming, the conductor shall not be nicked, cut or scraped to the point that base metal is exposed.</p> <p>NASA-STD-8739.3 [13.6.2.a.8] NASA-STD-8739.4 [19.6.2.a.1]</p>

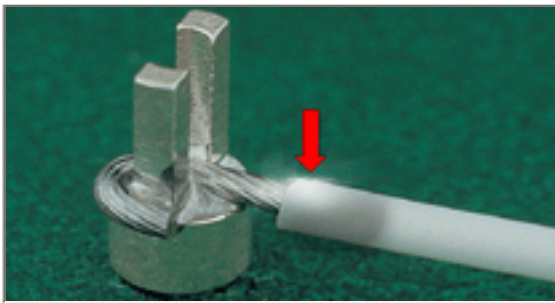

**UNACCEPTABLE
EXCESSIVE WICKING**

The use of flux and the solder-tinning operation shall be controlled to limit wicking under the insulation.

[NASA-STD-8739.3 \[7.2.5\]](#)

[NASA-STD-8739.4 \[10.1.5\]](#)

NASA WORKMANSHIP STANDARDS			
 <p>NATIONAL AERONAUTICS AND SPACE ADMINISTRATION JOHNSON SPACE CENTER HOUSTON, TEXAS USA 77058</p>	Released: 06.27.2002	Revision:	Revision Date:
	Book: 6	Section: 6.02	Page: 5





[Need a printed copy?](#)
(May take a while to load.)
[Requires Adobe Reader.](#)



[Need Adobe Reader?](#)
[Click here to download.](#)

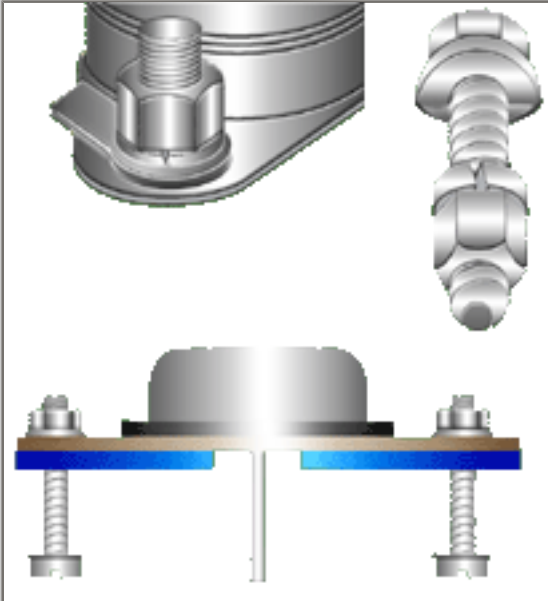
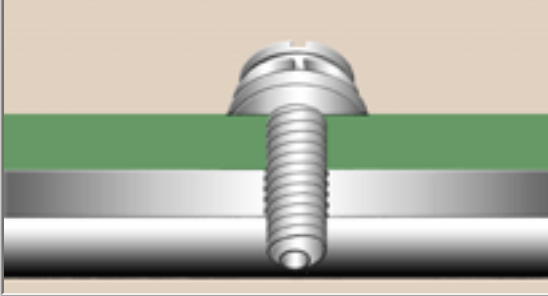
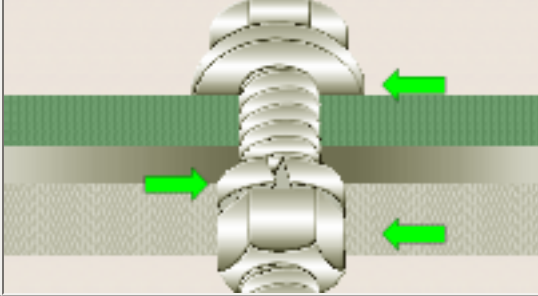

[Questions? Suggestions?](#)

THROUGH-HOLE SOLDERING MECHANICAL ASSEMBLY, HARDWARE			
	<p align="center"><u>MECHANICAL ASSEMBLY- HARDWARE</u></p> <p>Mechanical assembly hardware refers to the mounting of electrical and electronic components to a printed wiring board (PWB), or any other types of assemblies requiring the use of screws, bolts, nuts, fasteners, clips, component studs, adhesives, tie downs, rivets, connector pins, etc.</p> <p>See Section 6.01 "Through-Hole Soldering, General Requirements", for common accept/reject criteria.</p>		
			
<p align="center">PREFERRED BLIND FASTENER SEQUENCE</p> <p>Fasteners shall be assembled and installed in the sequence depicted, or per engineering documentation.</p> <p>Note: Self-tapping fasteners shall not be used for flight hardware.</p> <p>Best Workmanship Practice</p>	<p align="center">PREFERRED FASTENER SEQUENCE</p> <p>Fasteners shall be assembled and installed in the sequence depicted or per engineering documentation.</p> <p>Best Workmanship Practice</p>		
	 <p>L Min</p>		
<p align="center">PREFERRED THREAD PROTRUSION (L)</p> <p>A minimum of 1-1/2 threads shall extend beyond the threaded hardware (e.g., nut), unless otherwise specified by the engineering documentation.</p> <p>Best Workmanship Practice</p>	<p align="center">ACCEPTABLE THREAD PROTRUSION (L) - MINIMUM</p> <p>Thread extension may be flush with the edge of the threaded hardware when complete thread engagement can be visually verified, or where protruding threads could present an interference (electrical/mechanical) or snag threat.</p> <p>Best Workmanship Practice</p>		
<p>NASA WORKMANSHIP STANDARDS</p>			
	<p>Released: 06.27.2002</p>	<p>Revision:</p>	<p>Revision Date:</p>



THROUGH-HOLE SOLDERING
 MECHANICAL ASSEMBLY, HARDWARE (cont.)

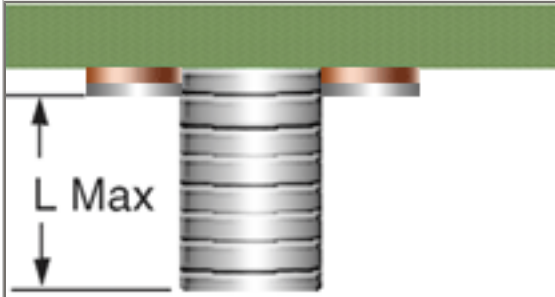

ACCEPTABLE
 THREAD PROTRUSION (L)-MAXIMUM

Thread extension should not be more than 3.0 mm (0.12 in.), plus 1-1/2 threads for bolts or screws up to 25 mm (0.984 in.) in length, or 6.3 mm (0.248 in.) plus 1-1/2 thread for bolts/screws over 25 mm (0.984 in.) in length.

[Best Workmanship Practice](#)

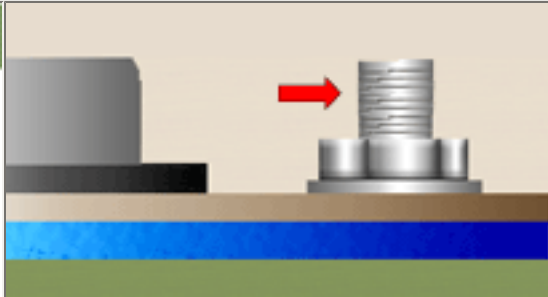

UNACCEPTABLE
 EXCESS THREAD PROTRUSION (L)

Excess thread protrusion represents an assembly, interference and electrical separation problem, as well as adds unnecessary weight to the assembly.

[Best Workmanship Practice](#)

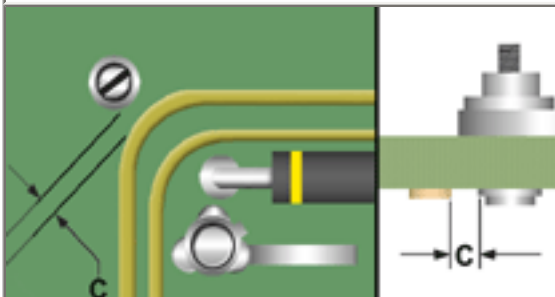

ACCEPTABLE
 ELECTRICAL CLEARANCE (C)

The mounting of hardware shall not violate minimum electrical spacing requirements.

[Best Workmanship Practice](#)

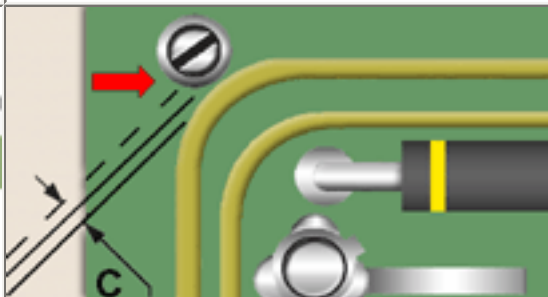

UNACCEPTABLE
 IMPROPER ELECTRICAL CLEARANCE (C)

The mounting hardware violates minimum electrical spacing requirements. This may result in electrical shorts or mechanical stress to the nearby circuit trace.

[Best Workmanship Practice](#)

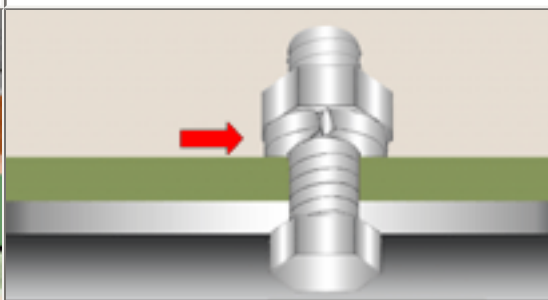
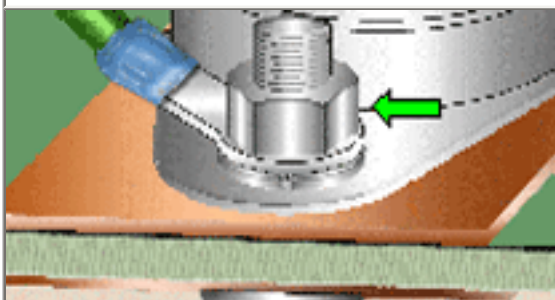

<p>ACCEPTABLE FASTENER ASSEMBLY</p> <p>The fasteners are properly installed and tight. Split-ring lock washer is fully compressed.</p> <p>Best Workmanship Practice</p>	<p>UNACCEPTABLE IMPROPER FASTENER SEQUENCE</p> <p>The lock washer has been installed against a nonmetallic/laminate surface. The flat washer is missing.</p> <p>Best Workmanship Practice</p>
--	--

NASA WORKMANSHIP STANDARDS

 <p>NATIONAL AERONAUTICS AND SPACE ADMINISTRATION JOHNSON SPACE CENTER HOUSTON, TEXAS USA 77058</p>	Released: 06.27.2002	Revision:	Revision Date:
	Book: 6	Section: 6.03	Page: 2

**THROUGH-HOLE SOLDERING
MECHANICAL ASSEMBLY, HARDWARE (cont.)**

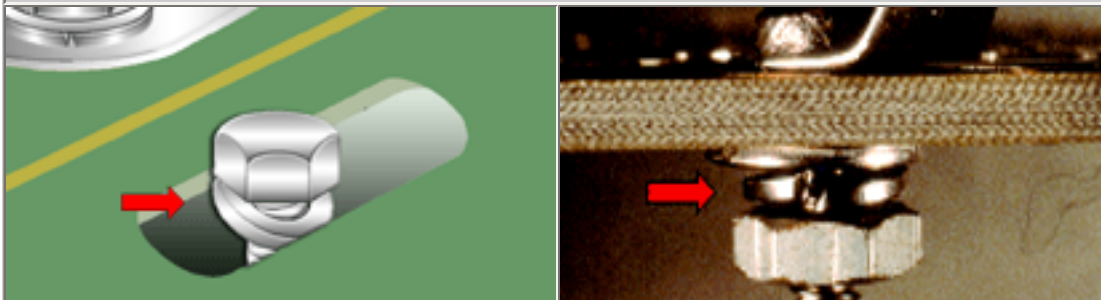

**UNACCEPTABLE
IMPROPER FASTENER SEQUENCE**

The hardware is missing or improperly installed.

[Best Workmanship Practice](#)

**UNACCEPTABLE
LOOSE FASTENER**

The fastener is not completely tightened, resulting in the incomplete compression of the lock washer.

[Best Workmanship Practice](#)

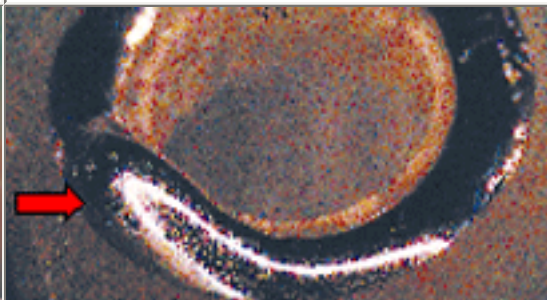
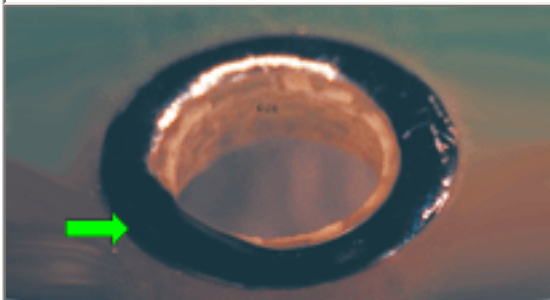

**ACCEPTABLE
MOUNTING HOLE SURFACE**

The surface of mounting holes shall be smooth and level, ensuring the mounting hardware will exert even pressure when installed.

[Best Workmanship Practice](#)

**UNACCEPTABLE
UNEVEN MOUNTING SURFACE**

Excess solder on the mounting hole surface prevents the mounting hardware from properly seating.

[Best Workmanship Practice](#)

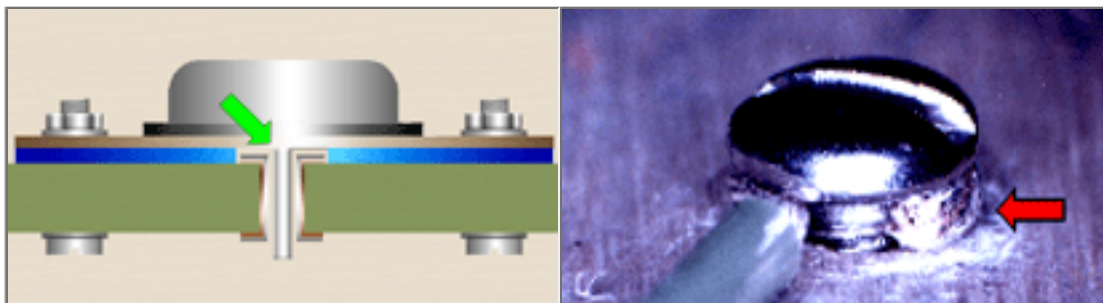

**UNACCEPTABLE
HOLE OBSTRUCTION**

Parts and components shall be mounted so that they do not prevent the proper fill of plated-through holes required to be soldered.

[Best Workmanship Practice](#)

**UNACCEPTABLE
MISSING TERMINATION LUG**

Wires shall not be wrapped around a screw terminal.

[Best Workmanship Practice](#)

NASA WORKMANSHIP STANDARDS

 <p>NATIONAL AERONAUTICS AND SPACE ADMINISTRATION JOHNSON SPACE CENTER HOUSTON, TEXAS USA 77058</p>	Released: 06.27.2002	Revision:	Revision Date:
	Book: 6	Section: 6.03	Page: 3



[Need a printed copy?](#)
(May take a while to load.)
Requires Adobe Reader.



[Need Adobe Reader?](#)
[Click here to download.](#)



[Questions? Suggestions?](#)

THROUGH-HOLE SOLDERING
MECHANICAL ASSEMBLY, POWER SEMICONDUCTORS & HEATSINKS

MECHANICAL ASSEMBLY
POWER SEMICONDUCTORS &
HEATSINKS

Power semiconductors and heatsinks present a unique challenge to the printed wiring board (PWB) designer. Power devices are capable of producing significant amounts of heat and are typically of greater mass than other components.

Body types vary from ceramic/ epoxy/ sandcast bodied and axial components requiring thermally-conductive staking and/or heatsinks; metallized housings with mounting tabs/feet; to axial, radial and multi-conductor/ flatpack components with integral heatsinks.

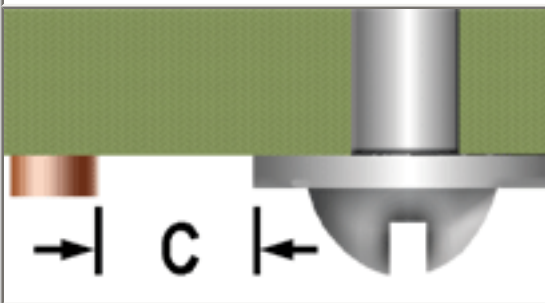
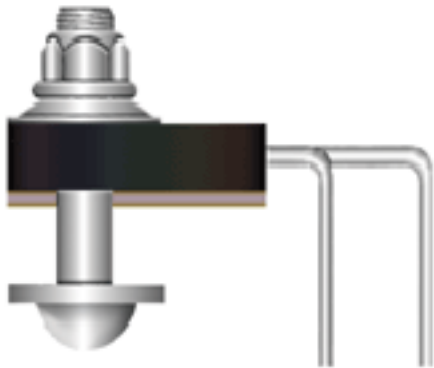

ACCEPTABLE
ELECTRICAL CLEARANCE (C)

The mounting of hardware shall not violate minimum electrical spacing requirements.

[Best Workmanship Practice](#)

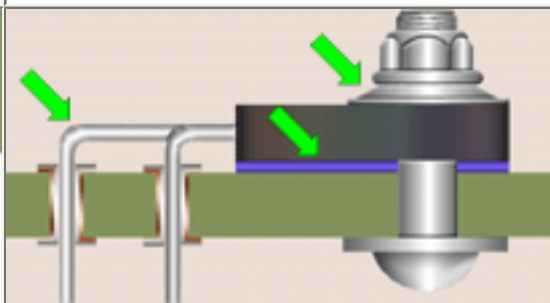

ACCEPTABLE
INTEGRAL HEATSINK COMPONENTS

Component and mounting hardware are installed per engineering documentation. Heatsink body and dielectric are undamaged and in full contact with no air gaps.

[Best Workmanship Practice](#)

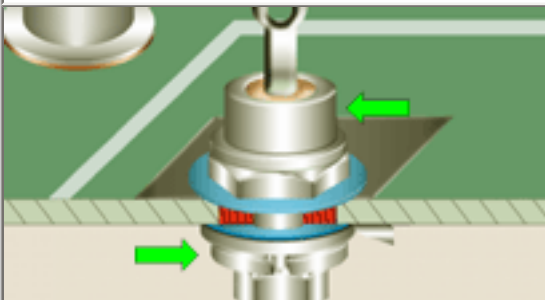

ACCEPTABLE
POWER DIODE INSTALLATION

Component and mounting hardware are properly installed.

[Best Workmanship Practice](#)

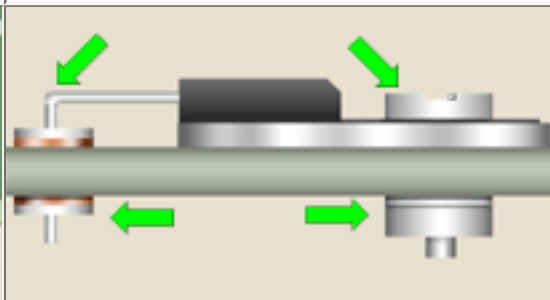

ACCEPTABLE
POWER TAB INSTALLATION

Component and mounting hardware are properly installed.



[Best Workmanship Practice](#)

 NATIONAL AERONAUTICS AND SPACE ADMINISTRATION JOHNSON SPACE CENTER HOUSTON, TEXAS USA 77058	Released: 06.27.2002	Revision:	Revision Date:
	Book: 6	Section: 6.04	Page: 1

NASA WORKMANSHIP STANDARDS			
 NATIONAL AERONAUTICS AND SPACE ADMINISTRATION JOHNSON SPACE CENTER HOUSTON, TEXAS USA 77058	Released: 06.27.2002	Revision:	Revision Date:
	Book: 6	Section: 6.04	Page: 2

		
Need a printed copy? <i>(May take a while to load.)</i> Requires Adobe Reader.	Need Adobe Reader? Click here to download.	Questions? Suggestions?

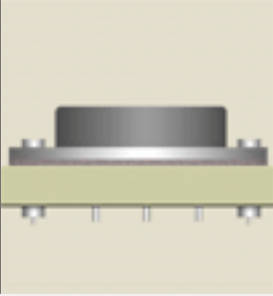
THROUGH-HOLE SOLDERING
 MECHANICAL ASSEMBLY, POWER SEMICONDUCTORS & HEATSINKS
 (cont.)

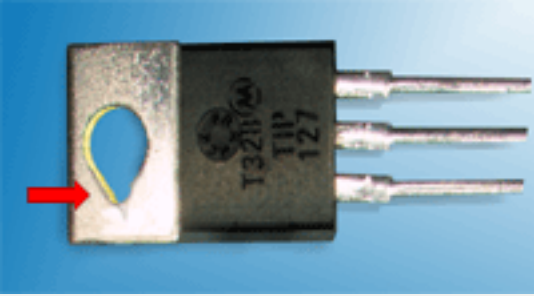
		
<p>ACCEPTABLE POWER TRANSISTOR INSTALLATION</p> Component and mounting hardware are properly installed. Best Workmanship Practice	<p>UNACCEPTABLE DAMAGED HEATSINK</p> Heatsink body exhibits gouging and deformation, resulting in exposed base metal. Reliability issue. Best Workmanship Practice	

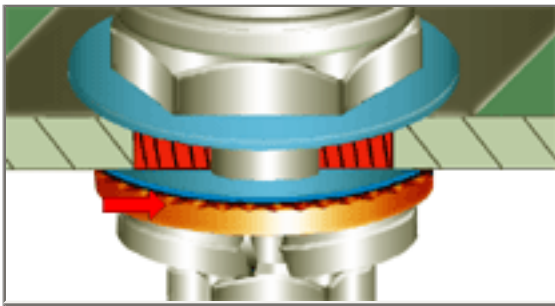

UNACCEPTABLE
IMPROPER MOUNTING HARDWARE
INSTALLATION SEQUENCE

Mounting hardware is improperly installed: the toothed surface of the flat washer is in contact with the insulator, which may result in insulator cut-through and reduced compression pressure.



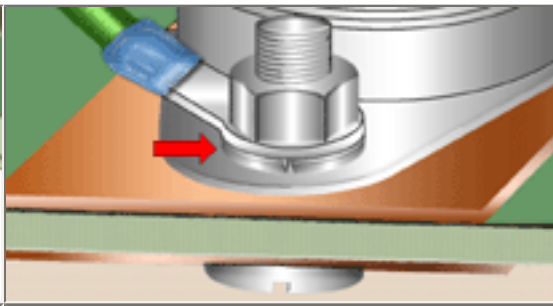

[Best Workmanship Practice](#)

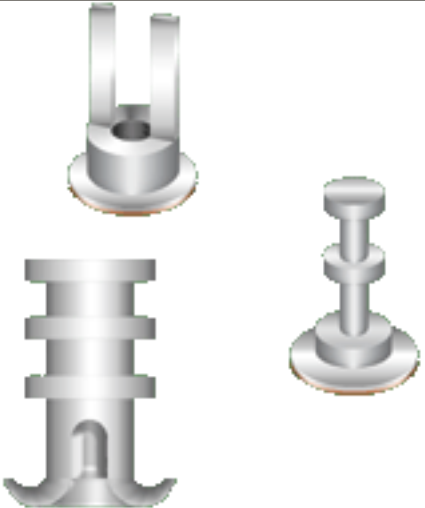

UNACCEPTABLE
IMPROPER MOUNTING HARDWARE
INSTALLATION SEQUENCE

Mounting hardware is improperly installed: the lock washer is located between the terminal lug and component case, rather than between the terminal lug and the nut.

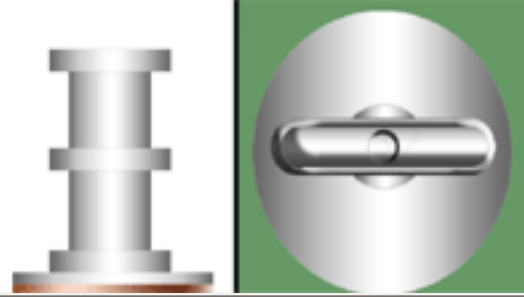
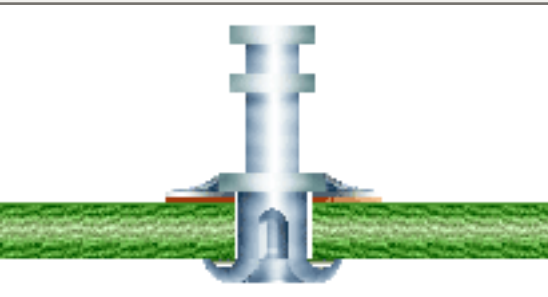
[Best Workmanship Practice](#)

THROUGH-HOLE SOLDERING MECHANICAL ASSEMBLY, SWAGED TERMINALS	
	<p><u>TERMINALS</u></p> <p>Terminals are generally restricted to applications requiring components to be routinely removed and replaced, such as in high-gain analog tuning circuits. The installation of terminals increases the vertical profile of the printed wiring assembly (PWA) significantly, requiring the designer to ensure minimum electrical spacing requirements are not violated.</p> <p>See Section 6.01 "Through-Hole Soldering, General Requirements", for common accept/reject criteria.</p>
	
<p>PREFERRED BIFURCATED TERMINAL</p> <p>The terminal is properly set, aligned and straight. Tines are straight. No exposed base metal. Flange is swaged sufficiently tight to prevent Z-axis movement, while allowing finger force twisting for adjustment. No damage to the PWB.</p>	<p>PREFERRED ELLIPTICAL FUNNEL SWAGE</p> <p>The flange is uniformly shaped and concentric to the hole or termination pad. Strain/Stress marks are minimum, no splits or cracks. Flange is swaged sufficiently tight to prevent Z-axis movement, while allowing finger force twisting for adjustment. No damage to the PWB.</p>
	
<p>PREFERRED ROLL FLANGE SWAGE</p> <p>The flange is uniformly rolled and concentric to the hole or termination pad. Strain/Stress marks are minimum, no splits or cracks. Flange is swaged sufficiently tight to prevent Z-axis movement, while allowing finger force twisting for adjustment. No damage to the PWB.</p>	<p>PREFERRED TURRET TERMINAL</p> <p>The terminal is properly set and straight. No exposed base metal. Flange is swaged sufficiently tight to prevent Z-axis movement, while allowing finger force twisting for adjustment. No damage to the PWB.</p>
<p>NASA WORKMANSHIP STANDARDS</p>	

 NATIONAL AERONAUTICS AND SPACE ADMINISTRATION JOHNSON SPACE CENTER HOUSTON, TEXAS USA 77058	Released: 06.27.2002	Revision:	Revision Date:
	Book: 6	Section: 6.05	Page: 1

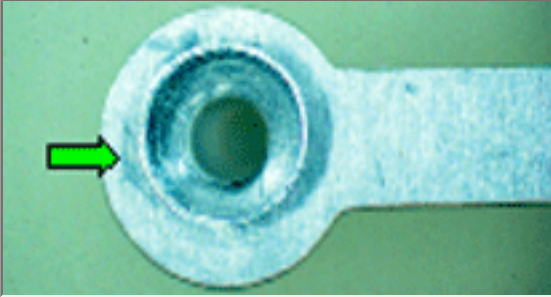
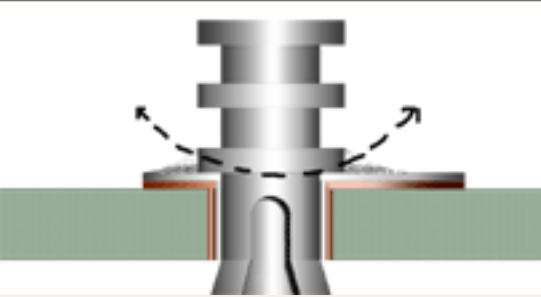
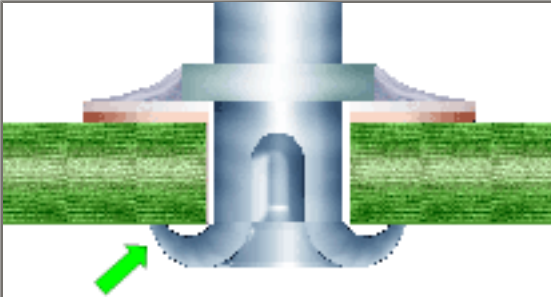
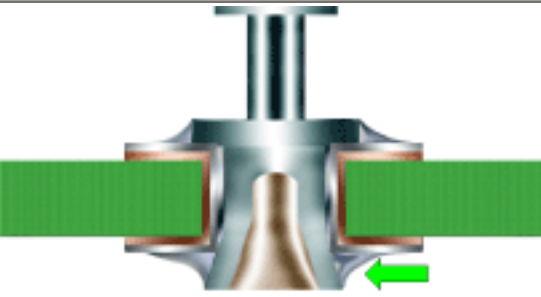
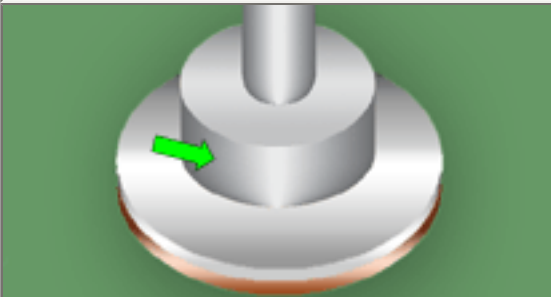
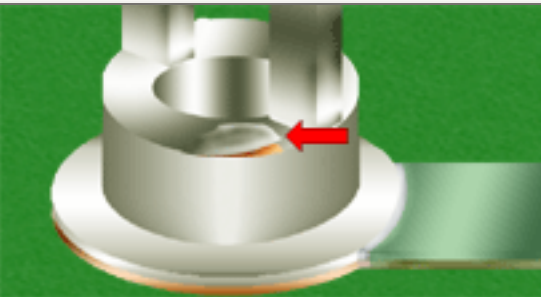
THROUGH-HOLE SOLDERING MECHANICAL ASSEMBLY, SWAGED TERMINALS (cont.)	
	
<p align="center">PREFERRED V-FUNNEL FLANGE</p> <p>The flange is uniformly swaged and concentric to the hole/ pad, and is sufficiently tight to prevent Z-axis movement, while allowing finger force twisting for adjustment. Minimum stress marks, no splits or cracks. No damage to the PWB.</p>	<p align="center">MANDATORY ADJUSTABILITY</p> <p>Terminals shall be swaged such that they can be rotated (twisted) under finger force. NASA-STD-8739.3 [8.2.4]</p>
	
<p align="center">MANDATORY COMPONENT SIDE TERMINATION ROLL SWAGE</p> <p>Swage type terminals in non-PTH's, designed to have the terminal shoulder soldered to the printed wiring conductor, shall be secured to the PWB by a roll swage. NASA-STD-8739.3 [8.2.2]</p>	<p align="center">ACCEPTABLE PLATED-THROUGH HOLE (PTH) TERM. V-FUNNEL/ELLIPTICAL SWAGE</p> <p>Terminals mounted in plated-through holes (PTH) shall be secured with a V-funnel or elliptical funnel swage. The elliptical funnel is preferred. NASA-STD-8739.3 [8.2.4]</p>
	

<p>MANDATORY PLATING</p> <p>Terminals shall be copper, hot dipped, tin-lead coated or hot reflowed, electrodeposited tin-lead solder. Finish shall be smooth and shiny.</p> <p>NASA-STD-8739.3 [9.1.12]</p>	<p>UNACCEPTABLE PLATING DEFECTS</p> <p>Flaking or peeling plating shall be grounds for rejection.</p> <p>Best Workmanship Practice</p>
--	---

NASA WORKMANSHIP STANDARDS			
 <p>NATIONAL AERONAUTICS AND SPACE ADMINISTRATION</p> <p>JOHNSON SPACE CENTER HOUSTON, TEXAS USA 77058</p>	Released:	Revision:	Revision Date:
	06.27.2002		
	Book:	Section:	Page:
6	6.05	2	

**THROUGH-HOLE SOLDERING
MECHANICAL ASSEMBLY, SWAGED TERMINALS (cont.)**

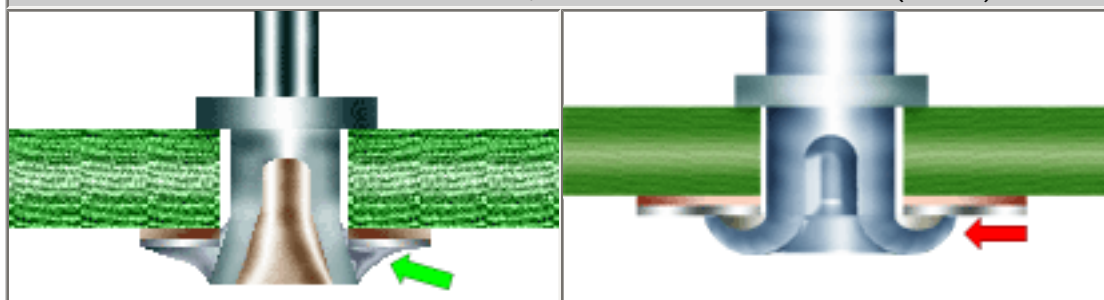

<p>MANDATORY SOLDER SIDE TERMINATION V-FUNNEL SWAGE</p> <p>Designs calling for soldering of the swaged end of the terminal to the printed wiring conductor on a single-sided PWB shall be secured with a V-funnel swage.</p> <p>NASA-STD-8739.3 [8.2.3]</p>	<p>UNACCEPTABLE IMPROPER SWAGE USED</p> <p>Designs calling for soldering of the swaged end of the terminal to the printed wiring conductor on a single-sided PWB shall be secured with a V-funnel swage.</p> <p>NASA-STD-8739.3 [13.6.2.a.14]</p>
--	--

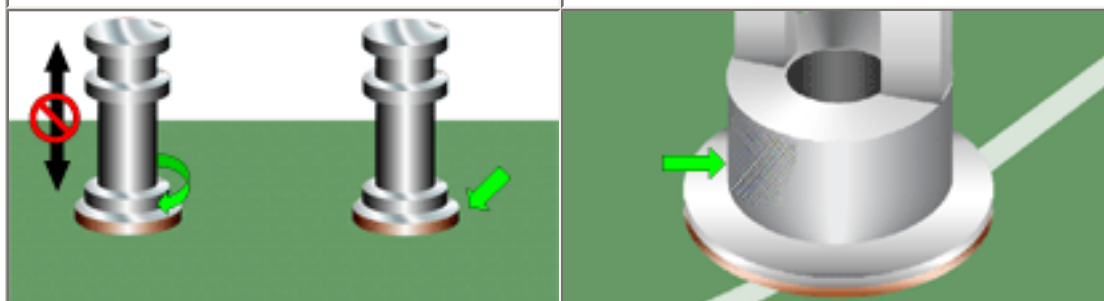

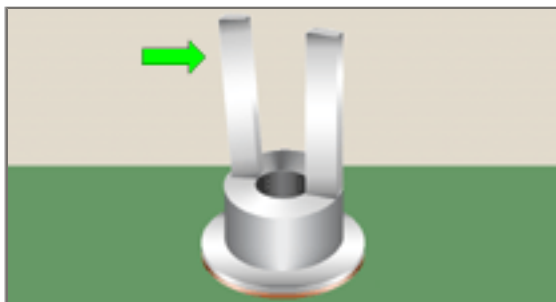
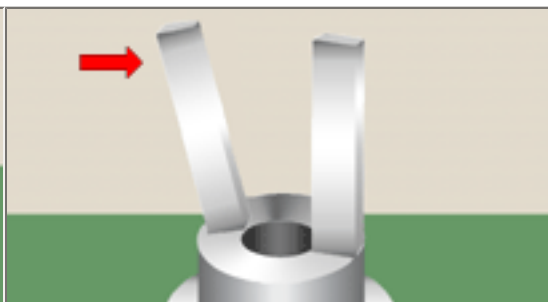

<p>ACCEPTABLE SWAGE SETTING</p> <p>The terminal shall be swaged sufficiently tight to prevent Z-axis movement, while allowing finger force twisting for adjustment. Swaging shall not damage the PWB or the termination pad.</p> <p>NASA-STD-8739.3 [8.2.1.a]</p>	<p>ACCEPTABLE SMOOTH IMPRESSION MARKS</p> <p>Smooth impression marks (base metal not exposed) resulting from tool holding forces shall not be cause for rejection.</p> <p>NASA-STD-8739.3 [7.2.3]</p>
--	--

	
<p style="text-align: center;">ACCEPTABLE RADIAL ALIGNMENT (BIFURCATED TERMINALS ONLY)</p> <p>The terminal is slightly twisted out of radial alignment, but the alignment will not adversely affect component installation or strain relief.</p> <p>Best Workmanship Practice</p>	<p style="text-align: center;">UNACCEPTABLE IMPROPER ALIGNMENT</p> <p>Bifurcated terminals shall be aligned to allow the proper termination of leads or conductors.</p> <p>Best Workmanship Practice</p>

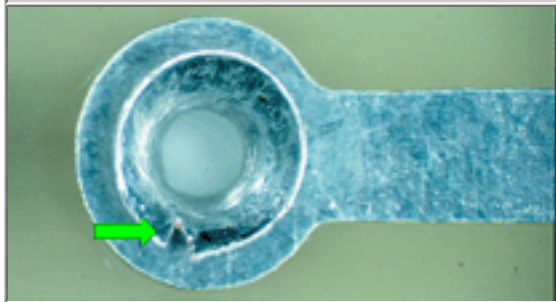
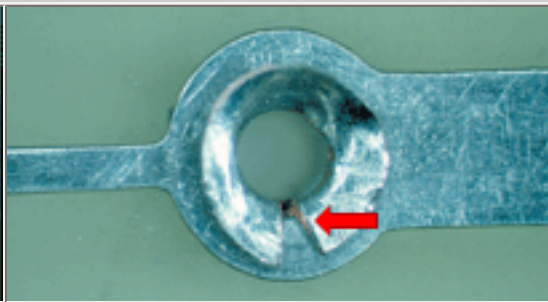
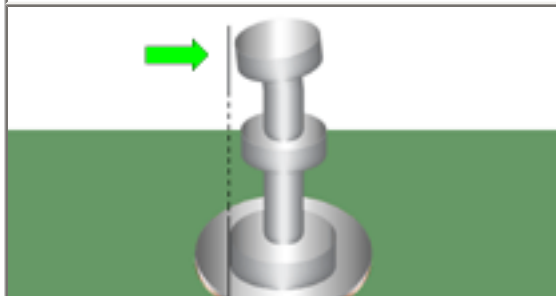
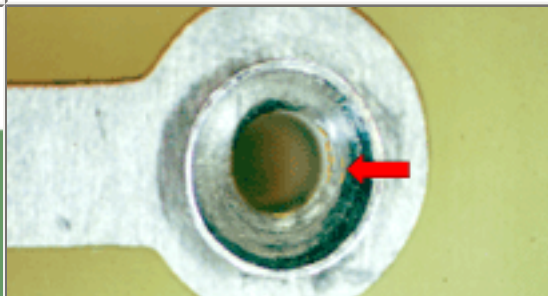
NASA WORKMANSHIP STANDARDS				
	<p>NATIONAL AERONAUTICS AND SPACE ADMINISTRATION JOHNSON SPACE CENTER HOUSTON, TEXAS USA 77058</p>	Released: 06.27.2002	Revision:	Revision Date:
		Book: 6	Section: 6.05	Page: 3

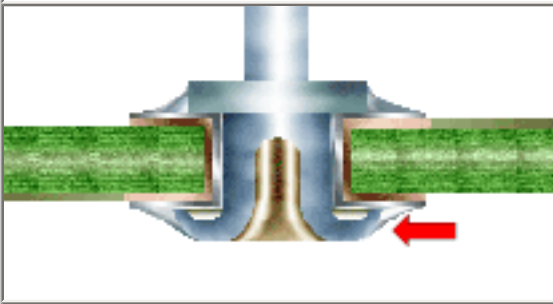
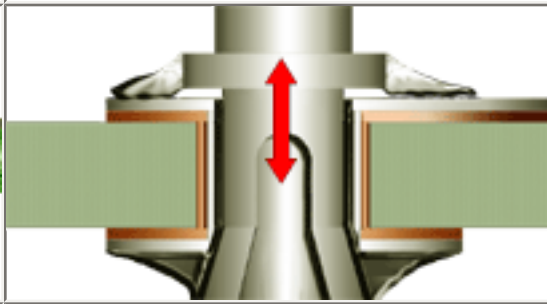
THROUGH-HOLE SOLDERING MECHANICAL ASSEMBLY, SWAGED TERMINALS (cont.)	
	
<p style="text-align: center;">ACCEPTABLE RADIAL SPLITS/CRACKS</p> <p>The rolled area or flange may have a maximum of 3 radial splits or cracks, which are separated by at least 90°, and/or which do not extend beyond the coiled or flared area.</p> <p>NASA-STD-8739.3 [8.2.1.b]</p>	<p style="text-align: center;">UNACCEPTABLE RADIAL SPLITS/CRACKS</p> <p>The rolled area or flange shall not have more than 3 radial splits or cracks, which are separated by less than 90°, and/or which extend beyond the coiled or flared area.</p> <p>NASA-STD-8739.3 [8.2.1.b], [13.6.2.a.14]</p>
	

<p style="text-align: center;">ACCEPTABLE VERTICAL MISALIGNMENT</p> <p>The terminal is slightly bent, but the top edge does not extend beyond the base, and alignment will not violate minimum electrical clearance.</p> <p>Best Workmanship Practice</p>	<p style="text-align: center;">UNACCEPTABLE CIRCUMFERENTIAL SPLITS/CRACKS</p> <p>After swaging or flaring, the rolled area or flange shall be free of circumferential splits or cracks.</p> <p>NASA-STD-8739.3 [8.2.1.b], [13.6.2.a.14]</p>
	
<p style="text-align: center;">UNACCEPTABLE IMPROPER SWAGE USED</p> <p>Roll swages shall not be used on plated-through holes.</p> <p>NASA-STD-8739.3 [8.2.2]</p>	<p style="text-align: center;">UNACCEPTABLE INCOMPLETE SWAGE</p> <p>The flange shall be swaged sufficiently tight to prevent movement in the Z-axis.</p> <p>Best Workmanship Practice</p>

NASA WORKMANSHIP STANDARDS				
	<p>NATIONAL AERONAUTICS AND SPACE ADMINISTRATION JOHNSON SPACE CENTER HOUSTON, TEXAS USA 77058</p>	<p>Released: 06.27.2002</p>	<p>Revision:</p>	<p>Revision Date:</p>
		<p>Book: 6</p>	<p>Section: 6.05</p>	<p>Page: 4</p>

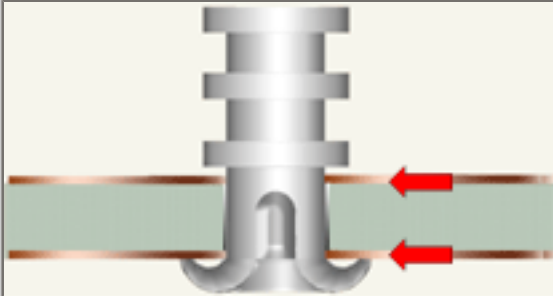
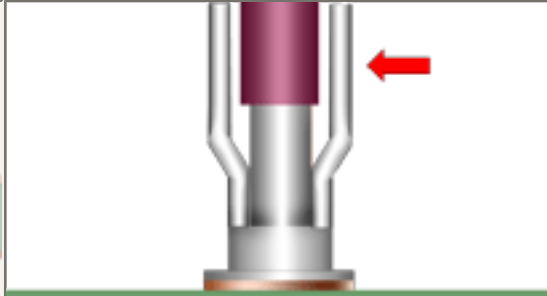
THROUGH-HOLE SOLDERING MECHANICAL ASSEMBLY, SWAGED TERMINALS (cont.)	
	
<p style="text-align: center;">UNACCEPTABLE INTERFACIAL CONNECTIONS</p> <p>Terminals shall not be used as interfacial connections in non-plated through holes.</p> <p>NASA-STD-8739.3 [8.2.1.a], [13.6.2.a.14]</p>	<p style="text-align: center;">UNACCEPTABLE MODIFICATIONS</p> <p>Terminals shall not be modified to accommodate improper conductor sizes.</p> <p>NASA-STD-8739.3 [7.3.2], [13.6.2.a.19]</p>

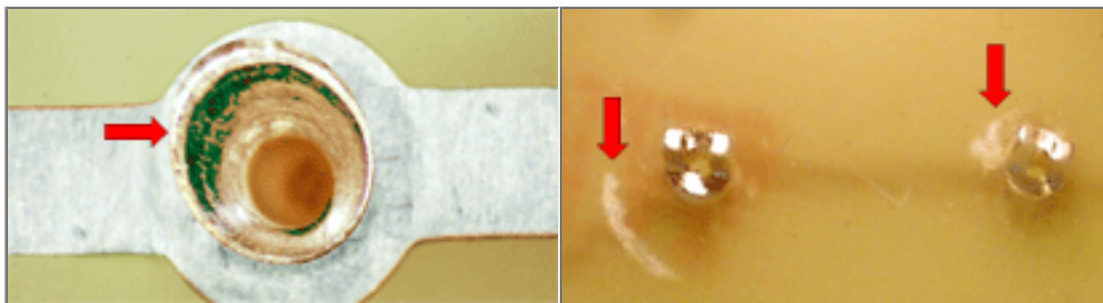

**UNACCEPTABLE
NONCONCENTRIC SWAGE**

The swage shall be set approximately concentric to the hole and/or termination pad.

[Best Workmanship Practice](#)

**UNACCEPTABLE
PWB DAMAGE**

The terminal has been swaged to the point that the substrate has been fractured and glass fiber is exposed.

[NASA-STD-8739.3 \[8.2.1.a\]](#)

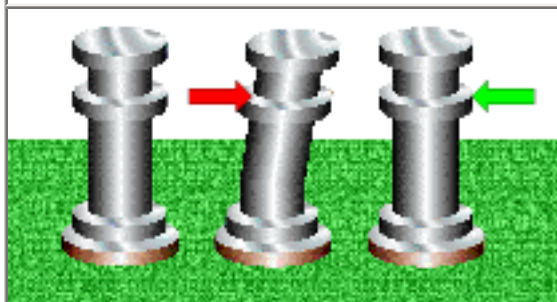

**UNACCEPTABLE
TERMINAL DAMAGE**

Terminals exhibiting physical damage (i.e.: nicks, gouging, bent/missing tines, reduced cross-section, etc.) shall be rejected.

[Best Workmanship Practice](#)

NASA WORKMANSHIP STANDARDS

 <p>NATIONAL AERONAUTICS AND SPACE ADMINISTRATION JOHNSON SPACE CENTER HOUSTON, TEXAS USA 77058</p>	Released: 06.27.2002	Revision:	Revision Date:
	Book: 6	Section: 6.05	Page: 5



[Need a printed copy?](#)
(May take a while to load.)
[Requires Adobe Reader.](#)



[Need Adobe Reader?](#)
[Click here to download.](#)



[Questions? Suggestions?](#)

THROUGH-HOLE SOLDERING MECHANICAL ASSEMBLY-COMPONENT SUPPORT, MECHANICAL	
	<p style="text-align: center;"><u>MECHANICAL ASSEMBLY COMPONENT SUPPORT, MECHANICAL</u></p> <p>Components weighing 7 grams (0.25 oz.) total, or 3.5 grams (0.12 oz.) per lead, shall be provided mechanical support and be bonded to the mounting surface to prevent vibration damage and to improve thermal management. Mechanical support (i.e.: fasteners, through-bolts, clips, etc.) can be used to satisfy this requirements, especially in applications where polymeric staking and bonding methods would not provide satisfactory results.</p> <p>See Section 6.01 "Through-Hole Soldering, General Requirements", for common accept/reject criteria.</p>
<p style="text-align: center;">ACCEPTABLE AXIAL COMPONENT CLIP</p> <p>Component is properly inserted in the clip, and leads exhibit proper bend radius and strain relief. Spacing between lands and uninsulated component body meet or exceed minimum electrical clearance.</p> <p>Best Workmanship Practice</p>	<p style="text-align: center;">ACCEPTABLE CABLE TIE HOLD DOWN</p> <p>The cable tie is approximately centered, smoothly dressed, and is holding the component firmly in place without deforming the case. The component does not exhibit any damage. Not recommended for high heat environments.</p> <p>Best Workmanship Practice</p>

<p>ACCEPTABLE RADIAL COMPONENT CLIP</p> <p>Component is properly inserted in the clip, and leads exhibit proper bend radius and strain relief. Spacing between lands and the uninsulated component body or clip meet or exceed minimum electrical clearance.</p> <p>Best Workmanship Practice</p>	<p>ACCEPTABLE WIRE HOLD DOWN</p> <p>The hold down wire is approximately centered, smoothly dressed, does not violate minimum electrical clearance requirements, and is holding the component firmly in place. The component does not exhibit any damage.</p> <p>Best Workmanship Practice</p>
--	--

NASA WORKMANSHIP STANDARDS			
 <p>NATIONAL AERONAUTICS AND SPACE ADMINISTRATION JOHNSON SPACE CENTER HOUSTON, TEXAS USA 77058</p>	Released: 06.27.2002	Revision:	Revision Date:
	Book: 6	Section: 6.06	Page: 1

**THROUGH-HOLE SOLDERING
MECHANICAL ASSEMBLY-COMPONENT SUPPORT, MECHANICAL
(cont.)**

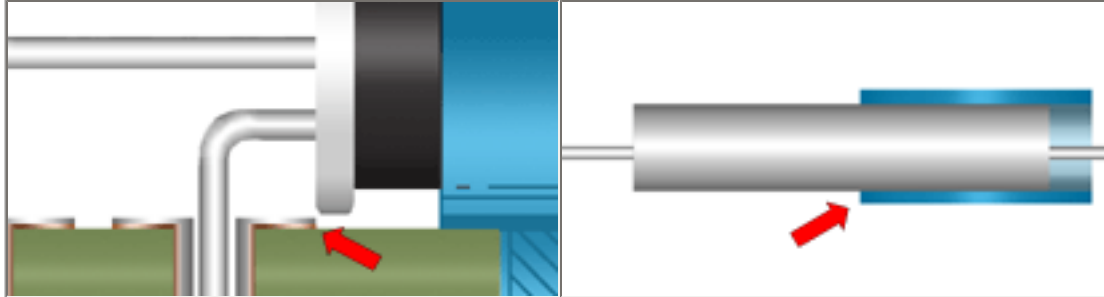

<p>UNACCEPTABLE IMPROPER ELECTRICAL CLEARANCE</p> <p>Spacing between the land and the uninsulated component body is less than the specified minimum electrical clearance.</p> <p>Best Workmanship Practice</p>	<p>UNACCEPTABLE IMPROPER POSITIONING</p> <p>The component is not properly positioned in the mounting hardware, which reduces the effectiveness of the support, and may result in unwanted movement and stress on the solder terminations.</p> <p>Best Workmanship Practice</p>
---	---

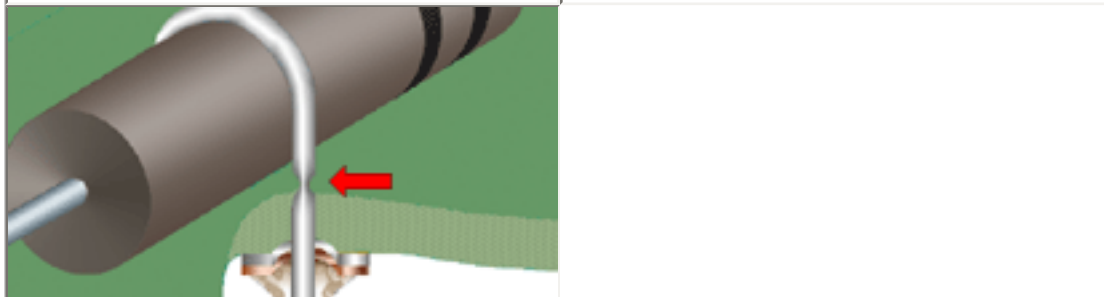

<p>UNACCEPTABLE KINKED HOLD-DOWN WIRE</p> <p>The hold-down wire exhibits a kink, which may reduce the strength and reliability of the wire, possible resulting in breakage. A kink against the component body may result in component damage or failure.</p> <p>Best Workmanship Practice</p>	
--	--

NASA WORKMANSHIP STANDARDS			
 NATIONAL AERONAUTICS AND SPACE ADMINISTRATION JOHNSON SPACE CENTER HOUSTON, TEXAS USA 77058	Released: 06.27.2002	Revision:	Revision Date:
	Book: 6	Section: 6.06	Page: 2





[Need a printed copy?](#)
(May take a while to load.)
Requires Adobe Reader.



[Need Adobe Reader?](#)
[Click here to download.](#)

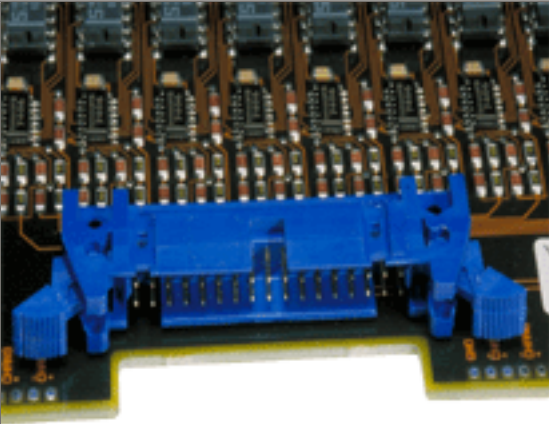
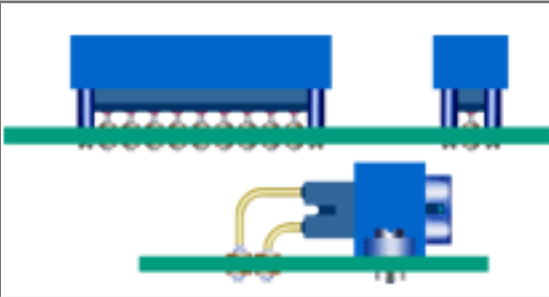
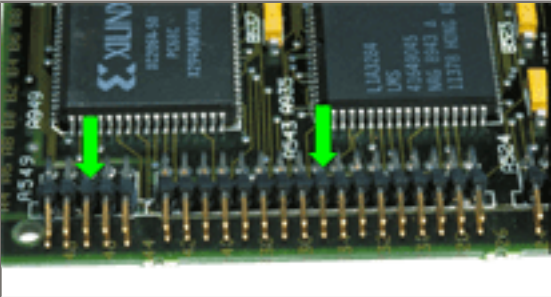

[Questions? Suggestions?](#)

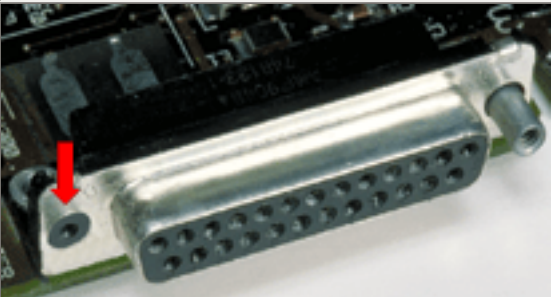
THROUGH-HOLE SOLDERING SOLDERED CONNECTORS	
	<p style="text-align: center;"><u>SOLDERED CONNECTORS</u></p> <p>Board-mounted connectors provide an electrical/mechanical solution to the problem of providing reliable input and output of power and signals to the printed wiring assembly (PWA). While the incorporation of connectors into a PWA may increase reliability, bulk and weight concerns, their use facilitates testing and field replacement, without the hardwiring of harnesses and cables to the PWA.</p> <p>Connectors are considered to be components and the mounting and soldering requirements are identical to those imposed on other through-hole components.</p>
	
<p>PREFERRED GENERAL REQUIREMENTS</p> <p>The connector body shall be parallel to and in full contact with the mounting surface. Standoff steps on all leads shall rest on the lands, and lead protrusion shall meet requirements. Mounting features (i.e.: board lock tabs or fasteners) shall be fully inserted and set.</p>	<p>PREFERRED KEYING</p> <p>Connectors should be keyed to prevent incorrect mating/interchanging with similar sized/colored connectors. Best Workmanship Practice</p>
	
<p>ACCEPTABLE ALTERNATIVE MECHANICAL MOUNTING</p> <p>Connectors not supplied with a locking tab or fastener system shall be secured with staking compound. Staking compound shall not be applied over conductive surfaces. Best Workmanship Practice</p>	<p>UNACCEPTABLE MISSING MOUNTING/CONNECTING HARDWARE</p> <p>Missing mounting/connecting hardware can interfere with the proper mating of the connector. Best Workmanship Practice</p>
<p>NASA WORKMANSHIP STANDARDS</p>	

 NATIONAL AERONAUTICS AND SPACE ADMINISTRATION JOHNSON SPACE CENTER HOUSTON, TEXAS USA 77058	Released: 06.27.2002	Revision:	Revision Date:
	Book: 6	Section: 6.07	Page: 1

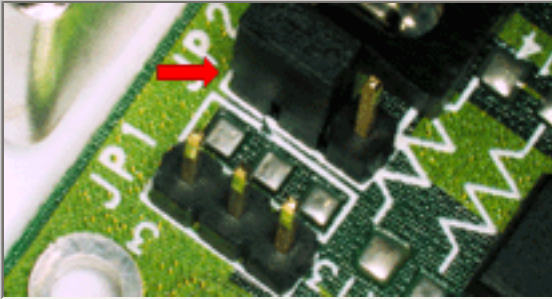
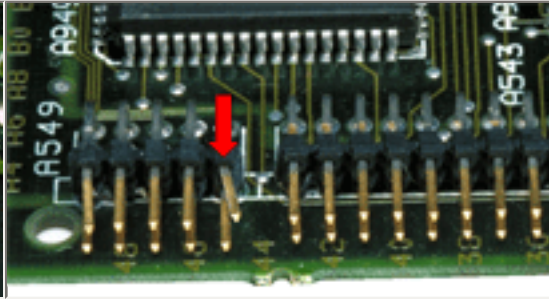
THROUGH-HOLE SOLDERING SOLDERED CONNECTORS (cont.)	
	
<p style="text-align: center;">UNACCEPTABLE JUMPER BLOCKS</p> <p>Jumper/selector blocks are not recommended for use in flight applications, without prior written approval. Provisions shall be made to ensure positive locking of jumper to prevent movement/unauthorized removal.</p> <p>Best Workmanship Practice</p>	<p style="text-align: center;">UNACCEPTABLE MECHANICAL DAMAGE</p> <p>Connectors exhibiting mechanical damage (i.e.: exposed base metal, dings, bent pins, broken mounts, missing EMI inserts, etc.) shall be rejected. Pins exhibiting minor bending may be reworked with approved tooling and processes.</p> <p>Best Workmanship Practice</p>

NASA WORKMANSHIP STANDARDS			
 NATIONAL AERONAUTICS AND SPACE ADMINISTRATION JOHNSON SPACE CENTER HOUSTON, TEXAS USA 77058	Released: 06.27.2002	Revision:	Revision Date:
	Book: 6	Section: 6.07	Page: 2



[Need a printed copy?](#)
(May take a while to load.)
Requires Adobe Reader.



[Need Adobe Reader?](#)
[Click here to download.](#)



[Questions? Suggestions?](#)

THROUGH-HOLE SOLDERING
SOLDERLESS (PRESS-FIT) CONNECTORS



SOLDERLESS (PRESS-FIT)
CONNECTORS

The use of high-density, high pin-count connectors (i.e.: backplane connectors, PC104, etc.) in multi-layer boards presents a technical challenge to the designer. The close pin geometries and thermal mass make reliable soldering extremely difficult.

Press-fit technology offers a "solderless" alternative, with spring-pin terminations that produce a reliable electrical termination with a gas-tight, mechanical fit to the plated-through hole.

Press-fit technology shall not be specified for flight applications without prior NASA approval.

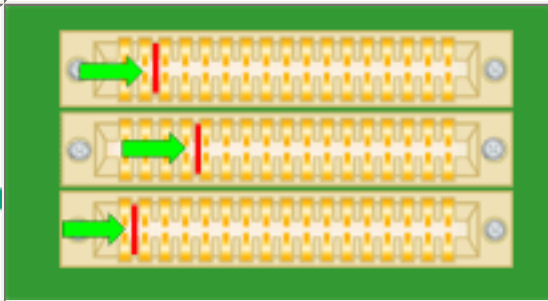
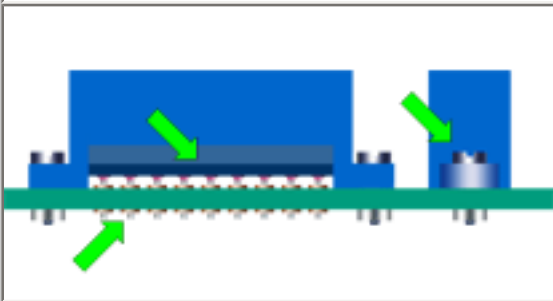

PREFERRED
GENERAL REQUIREMENTS

The connector has been properly installed, parallel to, and in full contact with the mounting surface. Pins are fully inserted, even, and meet minimum protrusion requirements. Mounting features (i.e.: board lock tabs or fasteners) have been fully inserted and set.

PREFERRED
KEYED

Connectors should be keyed to prevent incorrect mating/interchanging with similar sized/colored connectors.

[Best Workmanship Practice](#)

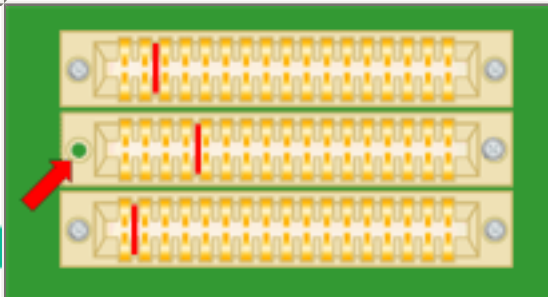
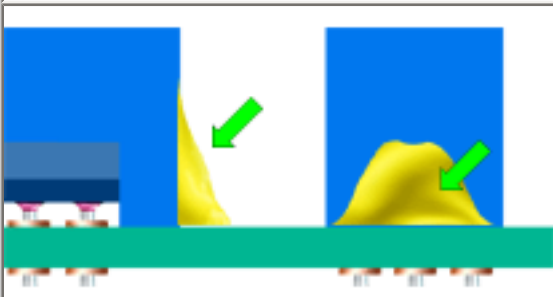

<p>ACCEPTABLE ALTERNATIVE MECHANICAL MOUNTING</p> <p>Connectors not supplied with a locking tab or fastener system shall be secured with staking compound. Staking compound shall not be applied over conductive surfaces.</p> <p>Best Workmanship Practice</p>	<p>UNACCEPTABLE MISSING MOUNTING/CONNECTING HARDWARE</p> <p>Missing mounting/connecting hardware can interfere with the proper mating of the connector.</p> <p>Best Workmanship Practice</p>
--	---

NASA WORKMANSHIP STANDARDS			
 <p>NATIONAL AERONAUTICS AND SPACE ADMINISTRATION JOHNSON SPACE CENTER HOUSTON, TEXAS USA 77058</p>	Released: 06.27.2002	Revision:	Revision Date:
	Book: 6	Section: 6.08	Page: 1

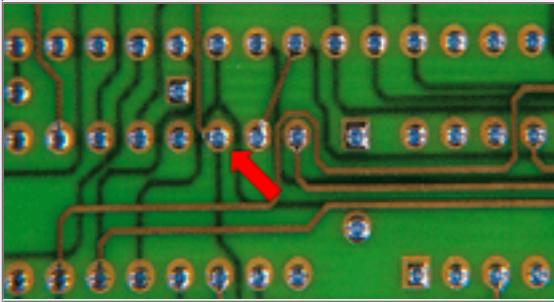
THROUGH-HOLE SOLDERING SOLDERLESS (PRESS-FIT) CONNECTORS (cont.)	
	<p>UNACCEPTABLE SOLDERED TERMINATIONS</p> <p>Solderless terminations are specifically designed for termination in plated-through holes (PTH) without soldering. The special design will prohibit the formation of a properly wetted solder interface between the pin and the PTH wall.</p> <p>Best Workmanship Practice</p>

NASA WORKMANSHIP STANDARDS			
 NATIONAL AERONAUTICS AND SPACE ADMINISTRATION JOHNSON SPACE CENTER HOUSTON, TEXAS USA 77058	Released: 06.27.2002	Revision:	Revision Date:
	Book: 6	Section: 6.08	Page: 2



[Need a printed copy?](#)
(May take a while to load.)
Requires Adobe Reader.



[Need Adobe Reader?](#)
[Click here to download.](#)



[Questions? Suggestions?](#)

**THROUGH-HOLE SOLDERING
AXIAL COMPONENTS**

AXIAL COMPONENTS

Axial-led components are often considered the most common type of discrete component used in through-hole printed wiring assembly.

See Section 6.01 "Through-Hole Soldering, General Requirements", for common accept/reject criteria.

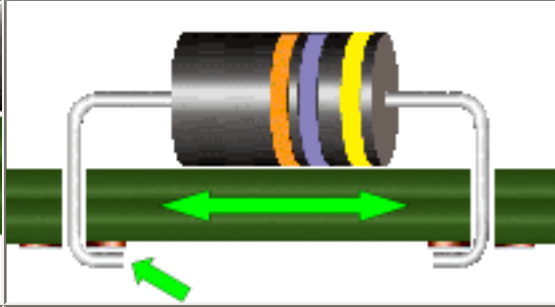
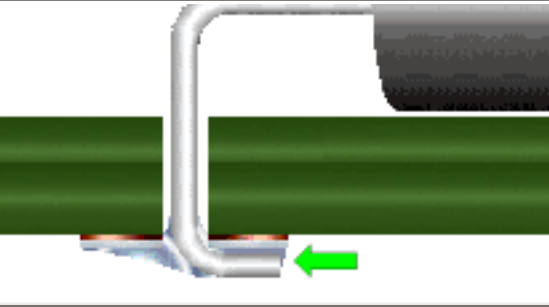
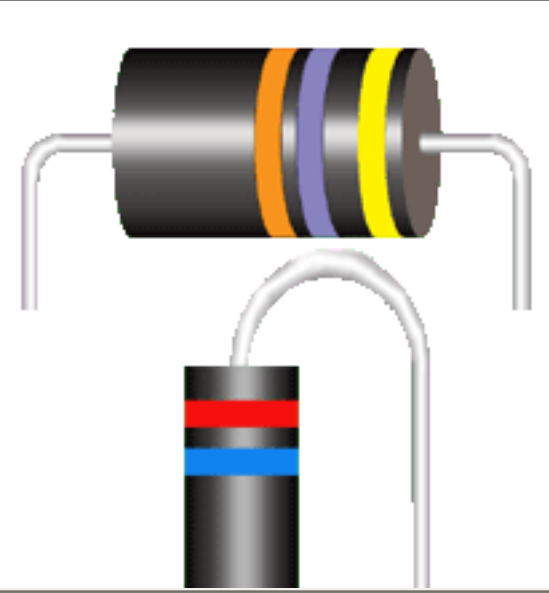

**PREFERRED
HORIZONTAL MOUNTING IN NPTH
COMPLETED ASSEMBLY**

The component terminations are completely wetted. The solder fillets are smooth, nonporous, undisturbed, exhibit a concave profile and extend to the edge of the termination pad.

[NASA-STD-8739.3 \[13.6.1\]](#)

**PREFERRED
HORIZONTAL MOUNTING IN NPTH
INTERIM ASSEMBLY**

Parts shall be parallel to and in full contact with the mounting surface, and centered between the termination holes. Leads shall be terminated with an off-the-pad solder joint.

[NASA-STD-8739.3 \[8.4.2.a\]](#)

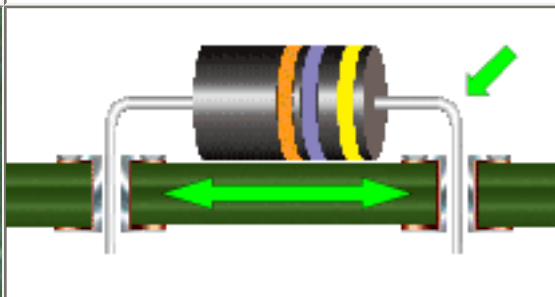
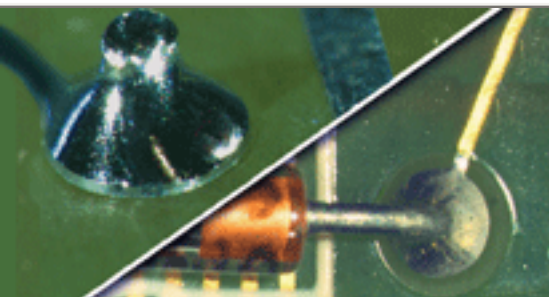

**PREFERRED
HORIZONTAL MOUNTING IN PTH
COMPLETED ASSEMBLY**

The component terminations on both sides of the board are completely wetted. The solder fillets are smooth, nonporous, undisturbed, exhibit a concave profile and extend to the edge of the termination pad.

[NASA-STD-8739.3 \[13.6.1.f\]](#)

**PREFERRED
HORIZONTAL MOUNTING IN PTH
INTERIM ASSEMBLY**

Parts shall be parallel to, and in full contact with the mounting surface and approximately centered between the termination holes. Leads exhibit proper stress relief bends and spacing.

[NASA-STD-8739.3 \[8.4.2.a\]](#)

NASA WORKMANSHIP STANDARDS

Released: 06.27.2002	Revision:	Revision Date:
-------------------------	-----------	----------------

 NATIONAL AERONAUTICS AND SPACE ADMINISTRATION JOHNSON SPACE CENTER HOUSTON, TEXAS USA 77058	Book:	Section:	Page:
	6	6.09	1

NASA WORKMANSHIP STANDARDS			
 NATIONAL AERONAUTICS AND SPACE ADMINISTRATION JOHNSON SPACE CENTER HOUSTON, TEXAS USA 77058	Released:	Revision:	Revision Date:
	06.27.2002		
	Book:	Section:	Page:
	6	6.09	2

NASA WORKMANSHIP STANDARDS			
 NATIONAL AERONAUTICS AND SPACE ADMINISTRATION JOHNSON SPACE CENTER HOUSTON, TEXAS USA 77058	Released:	Revision:	Revision Date:
	06.27.2002		
	Book:	Section:	Page:
	6	6.09	3

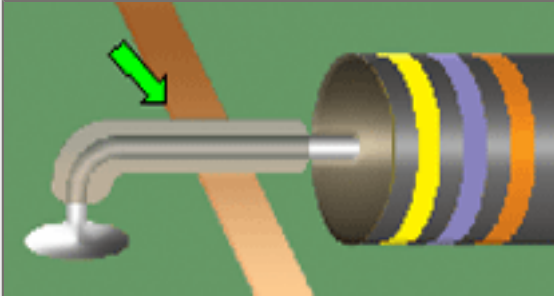
THROUGH-HOLE SOLDERING AXIAL COMPONENTS (cont.)	
	
<p>ACCEPTABLE LEADS CROSSING EXPOSED CONDUCTORS</p>	
<p>Leads crossing exposed conductors shall be sleeved with non-conductive sleeving or shrink tubing. Tubing shall be trimmed to meet insulation spacing requirements. Transparent/Translucent material is recommended.</p>	
<p>Best Workmanship Practice</p>	

NASA WORKMANSHIP STANDARDS			
 <p>NATIONAL AERONAUTICS AND SPACE ADMINISTRATION JOHNSON SPACE CENTER HOUSTON, TEXAS USA 77058</p>	Released: 06.27.2002	Revision:	Revision Date:
	Book: 6	Section: 6.09	Page: 4

		
<p>Need a printed copy? <i>(May take a while to load.)</i> Requires Adobe Reader.</p>	<p>Need Adobe Reader? Click here to download.</p>	<p>Questions? Suggestions?</p>

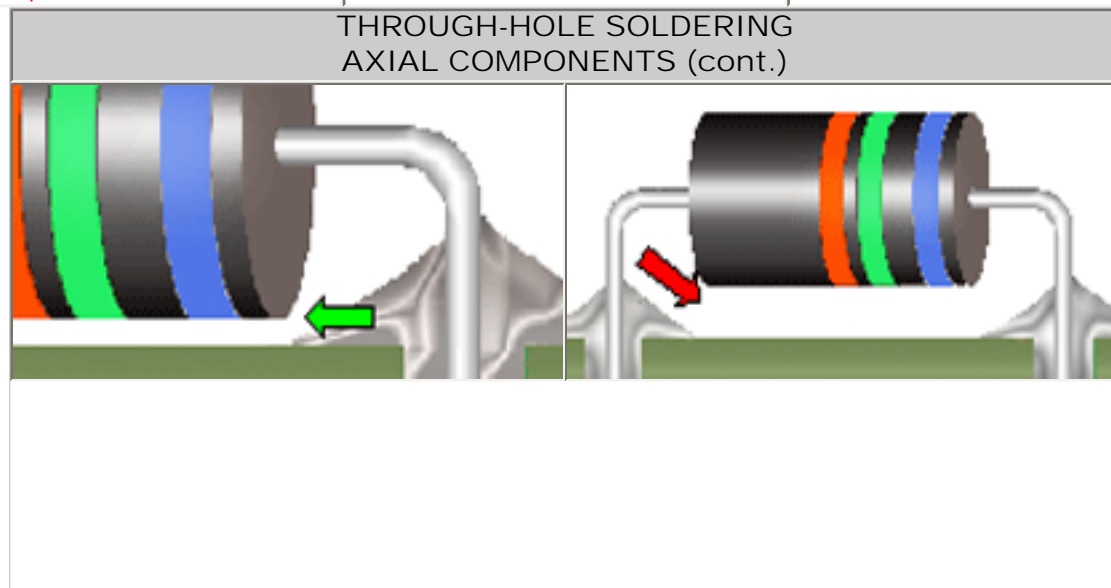

<p style="text-align: center;">ACCEPTABLE HORIZONTAL MOUNTING GAP</p> <p>When parts will be bonded, slight spacing [<math>\leq 0.68\text{ mm}</math> (0.025 in.)] will be acceptable. The part shall be mounted approximately parallel to the mounting surface.</p> <p>NASA-STD-8739.3 [8.4.2.a]</p>	<p style="text-align: center;">UNACCEPTABLE IMPROPER HORIZONTAL SPACING</p> <p>Parts intended for horizontal mounting shall be parallel to, and in contact with, the mounting surface. Part spacing above the mounting surface should not exceed 0.68 mm (0.025 in.) unless the part will be bonded.</p> <p>NASA-STD-8739.3 [8.4.2.a]</p>
	
<p style="text-align: center;">ACCEPTABLE STRESS RELIEF</p> <p>Stress relief shall be incorporated, wherever possible, into all leads and conductors in solder connections to provide freedom of movement of part leads or conductors between points of constraint. Camel-hump bend pictured.</p> <p>NASA-STD-8739.3 [8.1.1]</p>	<p style="text-align: center;">UNACCEPTABLE INSUFFICIENT STRESS RELIEF</p> <p>Stress relief shall be incorporated, wherever possible, into all leads and conductors in solder connections to provide freedom of movement of part leads or conductors between points of constraint.</p> <p>NASA-STD-8739.3 [8.1.1], [13.6.2.a.10]</p>
	
<p style="text-align: center;">UNACCEPTABLE IMPROPER VERTICAL MOUNTING NON-PLATED-THROUGH HOLE (NPTH)</p> <p>The component has been mounted with a space between the component end and the board surface, eliminating any mechanical support to the part or solder joint.</p> <p>NASA-STD-8739.3 [13.6.2.a.6]</p>	<p style="text-align: center;">UNACCEPTABLE IMPROPER VERTICAL MOUNTING PLATED THROUGH HOLE (PTH)</p> <p>The component has been mounted with the end of the component in contact with the plated-through-hole (PTH). This will result in solder contact with the part body meniscus.</p> <p>NASA-STD-8739.3 [8.4.2.b.1], [13.6.2.a.6]</p>
	
<p>THROUGH-HOLE SOLDERING AXIAL COMPONENTS (cont.)</p>	
	

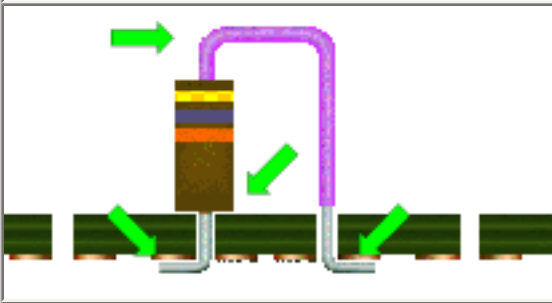
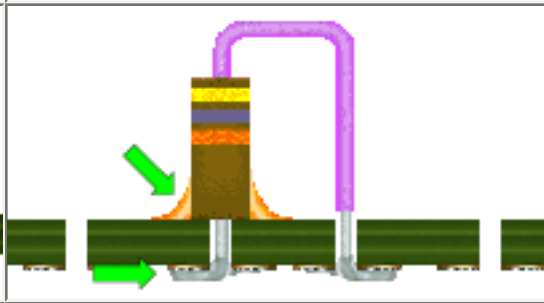
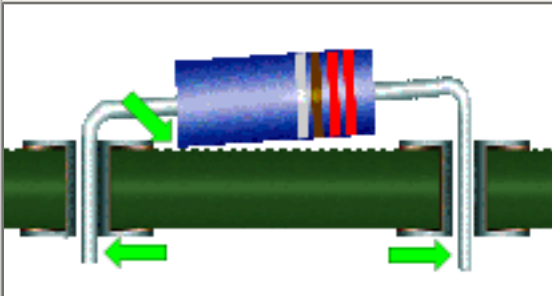
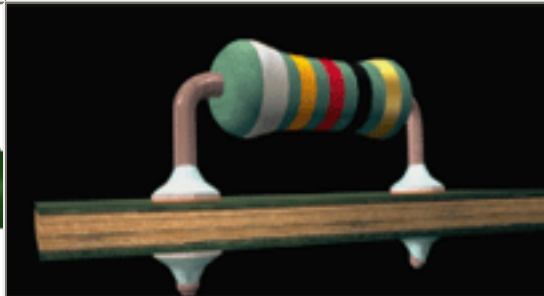
<p style="text-align: center;">PREFERRED VERTICAL MOUNTING IN PTH INTERIM ASSEMBLY</p> <p>The component shall be mounted with a minimum of 0.5 mm (0.020 in.) to a maximum of 1.27 mm (0.050 in.) clearance between the end of the component and the board surface.</p> <p>NASA-STD-8739.3 [8.4.2.b.1]</p>	<p style="text-align: center;">PREFERRED VERTICAL MOUNTING IN PTH COMPLETED ASSEMBLY</p> <p>The component terminations on both sides of the board are completely wetted. The solder fillets are smooth, nonporous, undisturbed, exhibit a concave profile, and extend to the edge of the termination pad.</p> <p>NASA-STD-8739.3 [13.6.1]</p>
	
<p style="text-align: center;">PREFERRED VERTICAL MOUNTING IN NPTH INTERIM ASSEMBLY</p> <p>The component shall be mounted with the end in contact with the board surface, and shall be terminated with an off-the-pad-lap solder joint. The opposite lead shall have 2 right angle bends.</p> <p>NASA-STD-8739.3 [8.4.2.b.2]</p>	<p style="text-align: center;">PREFERRED VERTICAL MOUNTING IN NPTH COMPLETED ASSEMBLY</p> <p>The component terminations are completely wetted. The solder fillets are smooth, nonporous, undisturbed, exhibit a concave profile and extend to the edge of the termination pad. The component is staked.</p> <p>NASA-STD-8739.3 [13.6.1]</p>
	
<p style="text-align: center;">ACCEPTABLE ANGULARITY</p> <p>Angularity shall not exceed 0.68 mm (0.025 in.), provided part of the component is in contact with the board, and the angularity does not violate minimum electrical spacing or lead protrusion requirements.</p> <p>Best Workmanship Practice</p>	<p style="text-align: center;">ACCEPTABLE HEAT PRODUCING PARTS</p> <p>Parts which dissipate heat in quantities of 1 Watt or greater, or in quantities sufficient to damage the laminate shall be mounted with sufficient standoff [≥ 1.5 mm (0.060 in.)] and shall be mechanically restrained.</p> <p>Best Workmanship Practice</p>

THROUGH-HOLE SOLDERING
RADIAL COMPONENTS

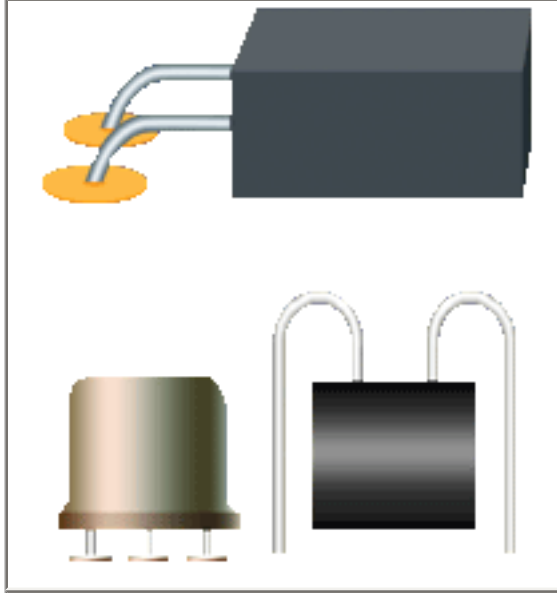

RADIAL COMPONENTS
Radial-leaded components are often used in the packaging of capacitors and transistor TO cans. Radials differ from axials in that the leads exit from a common side of the component, rather from opposite ends or sides. This gives the radial a vertical profile and a smaller printed wiring footprint.
See Section 6.01 "Through-Hole Soldering, General Requirements", for common accept/reject criteria.

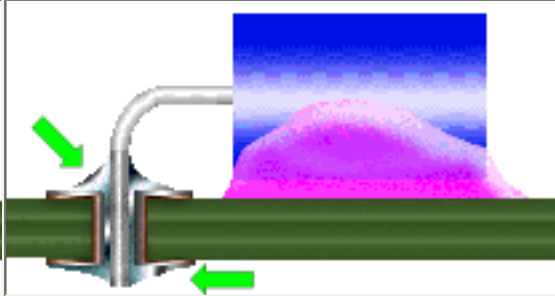
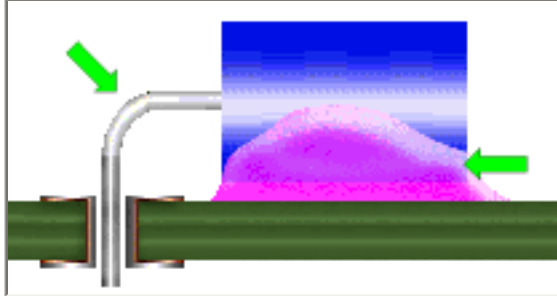

PREFERRED HORIZONTAL MOUNTING IN PTH INTERIM ASSEMBLY
The component body is in flat contact with, and bonded to the board surface. Component leads exhibit proper bend radius and bend spacing.
[Best Workmanship Practice](#)

PREFERRED HORIZONTAL MOUNTING IN PTH COMPLETED ASSEMBLY
The completed assembly exhibits proper solder fillet formation on both the component and solder sides of the printed wiring board (PWB).
[NASA-STD-8739.3 \[13.6.1\]](#)

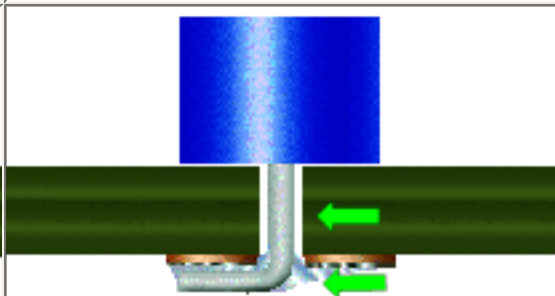
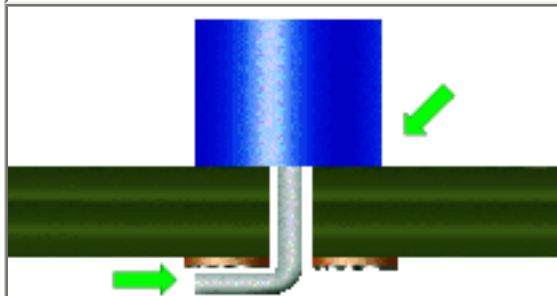



PREFERRED VERTICAL MOUNTING IN NPTH INTERIM ASSEMBLY
The component has been installed perpendicular to, and the base parallel to, the board. The component may be mounted on the PWB surface and terminated with an off-the-pad lap joint.
[NASA-STD-8739.3 \[8.4.3\]](#)

PREFERRED VERTICAL MOUNT IN NPTH COMPLETED ASSEMBLY
The component leads have been properly soldered. Solder has not wicked up through the non-plated-through-hole (NPTH) and contacted the lead seal/meniscus.
[NASA-STD-8739.3 \[8.4.3\]](#)

NASA WORKMANSHIP STANDARDS

Released: 06.27.2002	Revision:	Revision Date:
-------------------------	-----------	----------------

 NATIONAL AERONAUTICS AND SPACE ADMINISTRATION JOHNSON SPACE CENTER HOUSTON, TEXAS USA 77058	Book:	Section:	Page:
	6	6.10	1

NASA WORKMANSHIP STANDARDS			
 NATIONAL AERONAUTICS AND SPACE ADMINISTRATION JOHNSON SPACE CENTER HOUSTON, TEXAS USA 77058	Released:	Revision:	Revision Date:
	06.27.2002		
	Book:	Section:	Page:
	6	6.10	2

NASA WORKMANSHIP STANDARDS			
 NATIONAL AERONAUTICS AND SPACE ADMINISTRATION JOHNSON SPACE CENTER HOUSTON, TEXAS USA 77058	Released:	Revision:	Revision Date:
	06.27.2002		
	Book:	Section:	Page:
	6	6.10	3

		
<p>Need a printed copy? <i>(May take a while to load.)</i> Requires Adobe Reader.</p>	<p>Need Adobe Reader? Click here to download.</p>	<p>Questions? Suggestions?</p>

THROUGH-HOLE SOLDERING
RADIAL COMPONENTS (cont.)

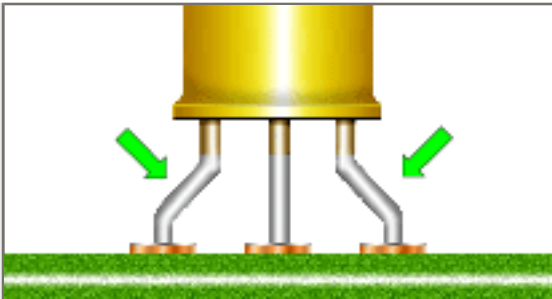
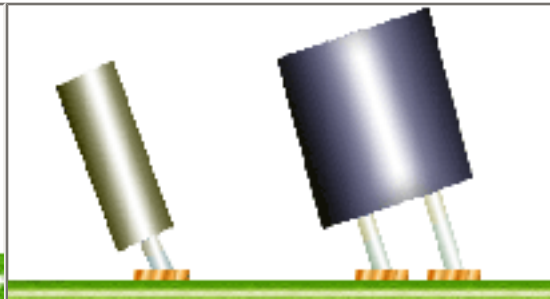
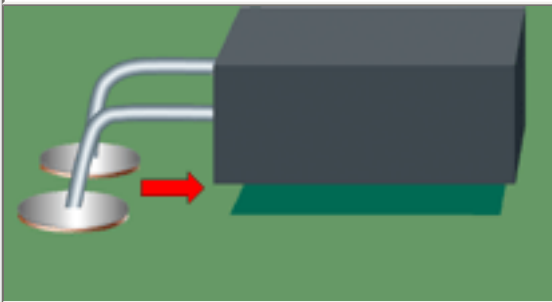
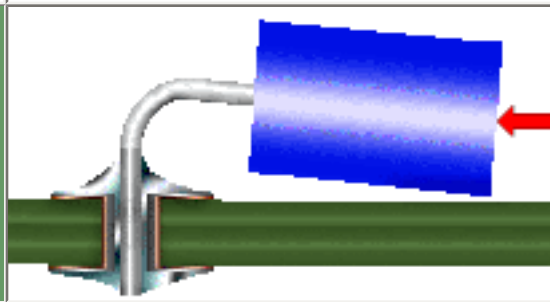
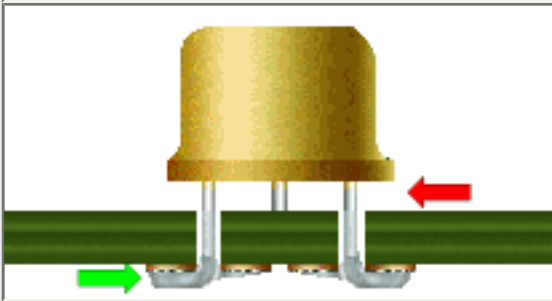
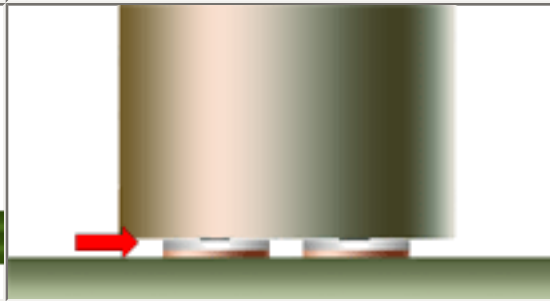
	
<p style="text-align: center;">ACCEPTABLE STRESS RELIEF</p> <p>Stress relief shall be incorporated, whenever possible, into all leads and conductors in solder connections to provide freedom of movement of part leads or conductors between points of constraint.</p> <p>NASA-STD-8739.3 [8.1.1]</p>	<p style="text-align: center;">ACCEPTABLE TILT</p> <p>Component tilt does not violate minimum electrical clearance or prohibit the installation or inspection of adjacent components.</p> <p>Best Workmanship Practice</p>
	
<p style="text-align: center;">UNACCEPTABLE IMPROPER HORIZONTAL MOUNTING</p> <p>The component body is not in contact with the mounting surface. This condition may be corrected through the use of underfill or staking material, if approved.</p> <p>Best Workmanship Practice</p>	<p style="text-align: center;">UNACCEPTABLE IMPROPER HORIZONTAL SPACING</p> <p>Parts intended for horizontal mounting shall be parallel to, and in contact with, the mounting surface. Part spacing above the mounting surface shall not exceed 0.70 mm (0.027 in.), unless the part will be bonded.</p> <p>NASA-STD-8739.3 [8.4.2.a]</p>
	
<p style="text-align: center;">UNACCEPTABLE IMPROPER VERTICAL SPACING NON-PLATED-THROUGH HOLE (NPTH)</p> <p>While the component has not been mounted with the end in contact with the board surface, the leads have been terminated with an off-the-pad-lap solder joint.</p> <p>NASA-STD-8739.3 [13.6.2.a.6]</p>	<p style="text-align: center;">UNACCEPTABLE IMPROPER VERTICAL SPACING PLATED THROUGH HOLE (PTH)</p> <p>The component has been mounted with the end of the component in contact with the plated-through-hole (PTH). This will result in solder contact with the part body meniscus.</p> <p>NASA-STD-8739.3 [8.4.2.b.1], [13.6.2.a.6]</p>
<p>THROUGH-HOLE SOLDERING RADIAL COMPONENTS (cont.)</p>	

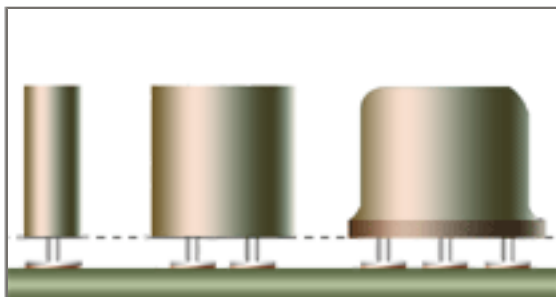
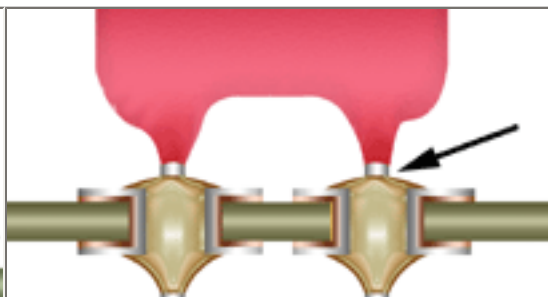
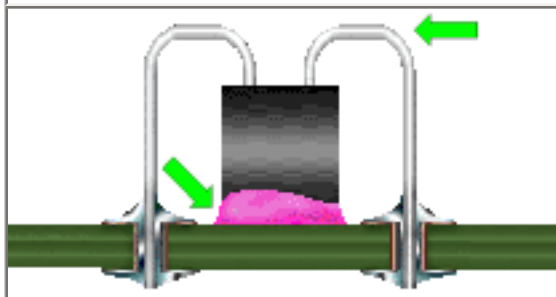
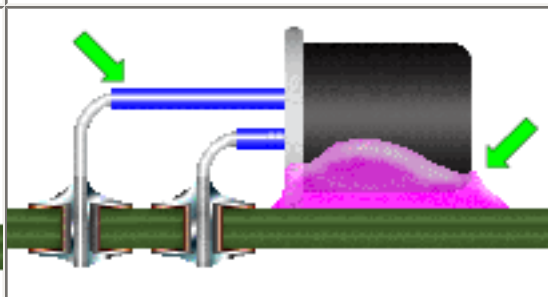
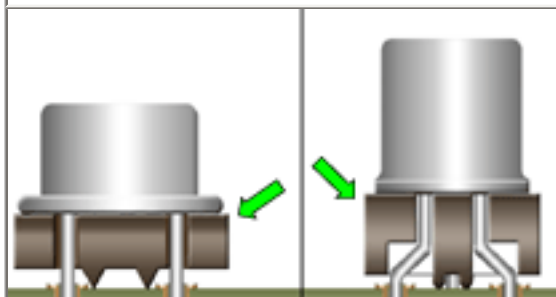
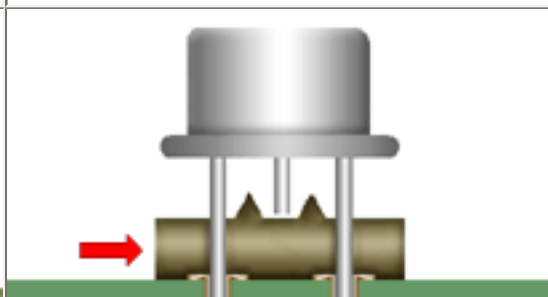
	
<p style="text-align: center;">PREFERRED VERTICAL MOUNTING IN PTH INTERIM ASSEMBLY</p> <p>The component(s) have been installed with the major axis perpendicular to, and the base parallel to, the board. Space between the base and board: 0.5 mm (0.020 in.) to 1.27 mm (0.050 in.). NASA-STD-8739.3 [8.4.3]</p>	<p style="text-align: center;">PREFERRED VERTICAL MOUNT IN PTH COMPLETED ASSEMBLY</p> <p>There is discernable clearance between the coating meniscus and the solder fillet. NASA-STD-8739.3 [8.4.3], [13.6.1]</p>
	
<p style="text-align: center;">ACCEPTABLE INVERTED MOUNTING</p> <p>Components mounted in an inverted position shall be bonded to the mounting surface. The leads shall be provided appropriate stress relief. Leads and devices with metal cases shall meet minimum electrical spacing requirements. Best Workmanship Practice</p>	<p style="text-align: center;">ACCEPTABLE SIDE MOUNT</p> <p>The component may be side mounted, provided appropriate stress relief and lead protection is provided. Best Workmanship Practice</p>
	
<p style="text-align: center;">ACCEPTABLE SPACERS</p> <p>The spacer is in full contact with both the component base and the board. The spacer's feet are in contact with the board, allowing the solder to flow to the topside of the board, and allow the terminations to be cleaned and visually inspected. Best Workmanship Practice</p>	<p style="text-align: center;">UNACCEPTABLE IMPROPERLY INSTALLED SPACER</p> <p>The spacer is not in contact with both the component base and the board, and is inverted, prohibiting proper solder flow to the topside of the board, or allow the terminations to be cleaned and visually inspected. Best Workmanship Practice</p>

THROUGH-HOLE SOLDERING
COMPONENT INSTALLATION-DUAL IN-LINE PACKAGES (DIPS)



COMPONENT INSTALLATION
DUAL IN-LINE PACKAGES (DIPS)

Dual In-Line Packages (DIPs) are the component body type most associated with printed wiring assemblies (PWA) using through-hole technology. The DIP body can be either plastic or ceramic with between 6 to 64 leads.

See Section 6.01 "Through-Hole Soldering, General Requirements", for common accept/reject criteria.

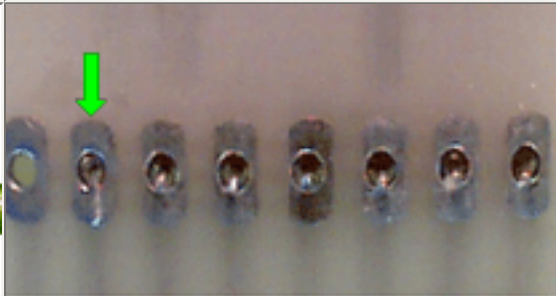

PREFERRED

The component has been properly oriented and all leads are fully inserted in the termination holes with the lead standoff step in contact with the lands. The component body is undamaged and part markings are legible and visible on top of component body.

**ACCEPTABLE
PARTIALLY CLINCHED LEADS**

The corner leads may be partially clinched outward from the ship body's longitudinal axis to temporarily secure the component. Clinching shall not violate minimum electrical spacing requirements or adversely affect solderability.

[Best Workmanship Practice](#)



**ACCEPTABLE
ORIENTATION/POLARITY**

The component has been properly installed. The locator chip's notch/dimple, which identifies pin 1, is lined up with the silkscreen pattern. A square-shaped solder pad on the printed wiring pattern may also be used to identify pin 1.

[NASA-STD-8739.3 \[8.1.3\]](#)

**UNACCEPTABLE
IMPROPER ORIENTATION/POLARITY**

The DIP has been installed backwards. The locator notch/dimple, which identifies pin 1 of the chip, should be lined up to the silkscreen and/or conductive pattern marks.

[NASA-STD-8739.3 \[13.6.2.a.5\]](#)

NASA WORKMANSHIP STANDARDS



**NATIONAL AERONAUTICS AND
SPACE ADMINISTRATION**
JOHNSON SPACE CENTER
HOUSTON, TEXAS USA 77058

Released:
06.27.2002

Revision:



Revision Date:

	Book: 6	Section: 6.11	Page: 1
--	------------	------------------	------------

NASA WORKMANSHIP STANDARDS			
 NATIONAL AERONAUTICS AND SPACE ADMINISTRATION JOHNSON SPACE CENTER HOUSTON, TEXAS USA 77058	Released: 06.27.2002	Revision:	Revision Date:
	Book: 6	Section: 6.11	Page: 2

		
Need a printed copy? <i>(May take a while to load.)</i> Requires Adobe Reader.	Need Adobe Reader? Click here to download.	Questions? Suggestions?

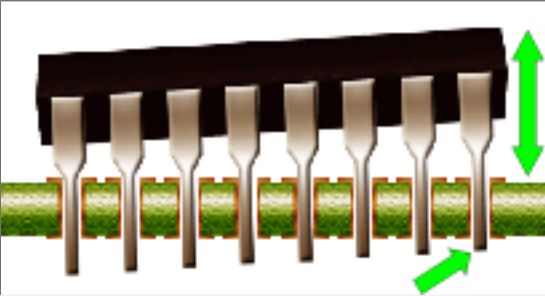
THROUGH-HOLE SOLDERING COMPONENT INSTALLATION - DUAL IN-LINE PACKAGES (DIPS) (cont.)

	
<p>ACCEPTABLE TILT</p> <p>The component exhibits minor tilting, but the tilt does not reduce lead protrusion below acceptable minimums, cause the component body to exceed height requirements, or violate minimum electrical spacing requirements.</p> <p>NASA-STD-8739.3 [8.1], [13.6.1]</p>	<p>UNACCEPTABLE EXCESS TILT</p> <p>Excess part tilt causes the leads to not meet minimum protrusion requirements. Excess tilt may cause the part to exceed maximum height requirements, or result in violation of minimum electrical clearance requirements.</p> <p>NASA-STD-8739.3 [13.6.2.a.21]</p>

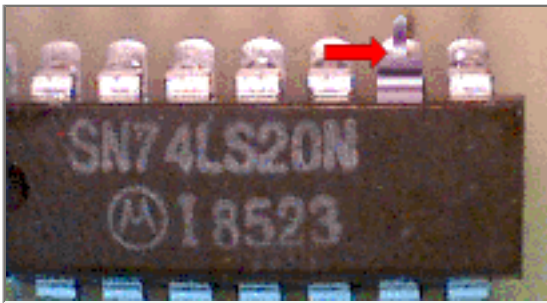

**UNACCEPTABLE
BENT/CURLED LEAD**

The lead has been smashed into the pad surface, preventing proper insertion. This may be caused by improper lead planarity, an improperly bent lead, or a solder-plugged hole.

[NASA-STD-8739.3 \[13.6.2.a.7\]](#), [\[13.6.2.a.21\]](#)



**UNACCEPTABLE
IMPROPER ORIENTATION/OFFSET**

The component has been incorrectly installed, with the chip offset with respect to the intended termination pattern. This failure is typically caused by insertion of the chip leads into the bypass capacitor mounting holes.

[NASA-STD-8739.3 \[13.6.2.a.5\]](#)

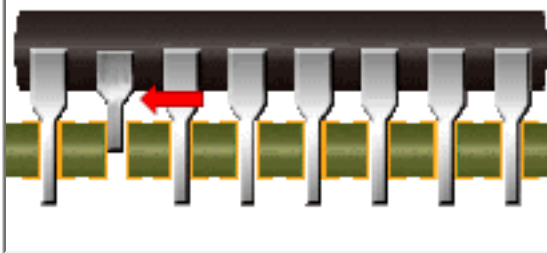

**UNACCEPTABLE
PISTONED LEAD**

The lead has been displaced vertically (pistoned) during insertion. This may be caused by improper lead planarity, an improperly bent lead, or a solder-plugged hole.

[NASA-STD-8739.3 \[13.6.2.a.7\]](#), [\[13.6.2.a.21\]](#)

THROUGH-HOLE SOLDERING
SINGLE IN-LINE PACKAGE (SIP)

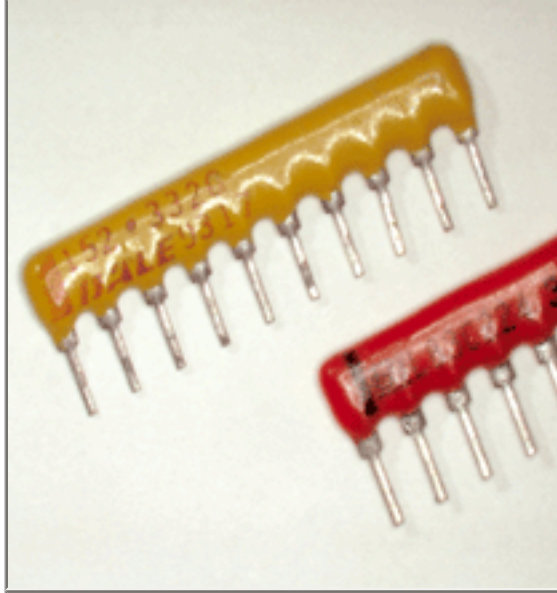

SINGLE IN-LINE PACKAGE (SIP)
Single-In-Line Package (SIP) components have a flat body oriented vertically to the printed wiring board and a single row of pins or leads. Most small-form SIPs are parallel-array devices of common value components (i.e. diode, resistor arrays). Large-form SIPs are usually hybrid circuits (i.e. timers, oscillators, etc.). The SIP body can be either plastic or ceramic with between 4 to 64 leads.
See Section 6.01 "Through-Hole Soldering, General Requirements", for common accept/reject criteria.

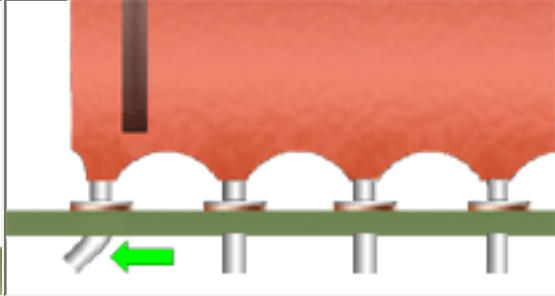
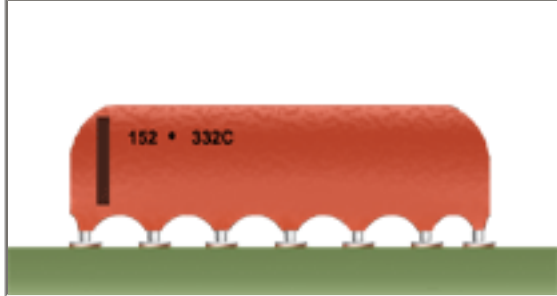

PREFERRED
The component has been properly oriented and all leads are fully inserted in the termination holes with the lead standoff step in contact with the lands. The component body is undamaged and part markings are legible and visible.

ACCEPTABLE PARTIALLY CLINCHED LEADS
The end leads may be partially clinched to temporarily secure the component. Clinching shall not violate minimum electrical spacing requirements, or adversely affect solderability.
[Best Workmanship Practice](#)

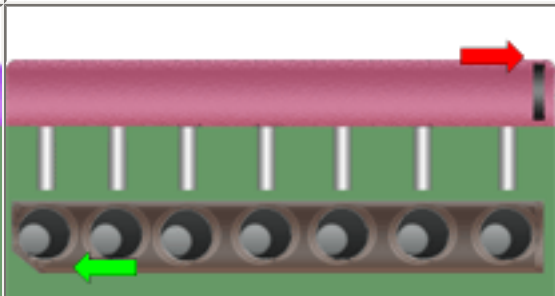
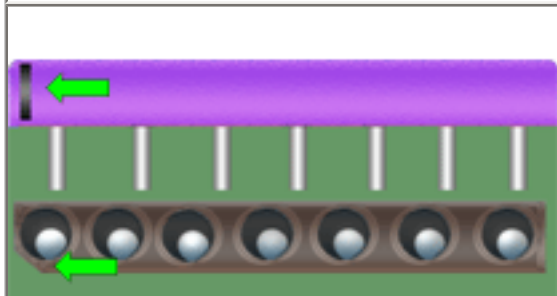

ACCEPTABLE ORIENTATION/POLARITY
The component has been properly installed. The chip's notch/paint stripe, which identifies pin 1, is lined up with the silkscreen pattern. A square-shaped solder pad on the printed wiring pattern may also be used to identify pin 1.
[NASA-STD-8739.3 \[8.1\]](#)

UNACCEPTABLE IMPROPER ORIENTATION/POLARITY
The SIP has been installed backwards. The locator notch/dimple, which identifies pin 1 of the chip, should be lined up to the silkscreen and/or conductive pattern marks.
[NASA-STD-8739.3 \[13.6.2.a.5\]](#)

NASA WORKMANSHIP STANDARDS



Released: 06.27.2002	Revision:	Revision Date:
-------------------------	-----------	----------------

	Book: 6	Section: 6.12	Page: 1
--	------------	------------------	------------

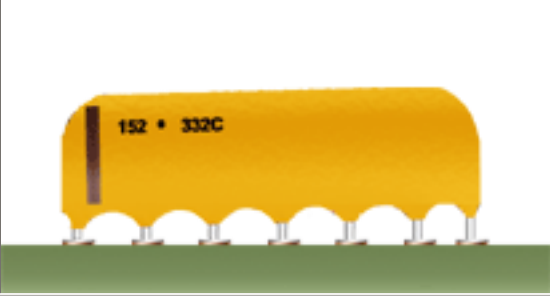
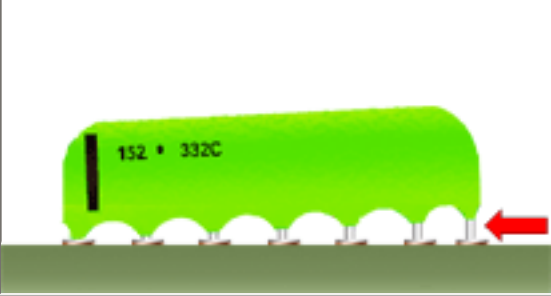
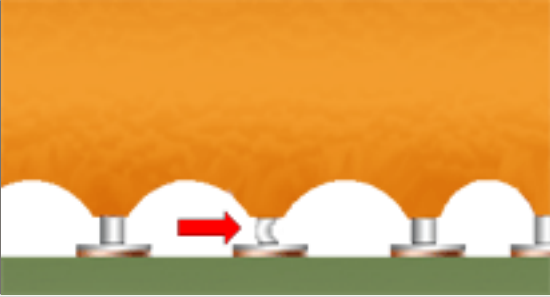
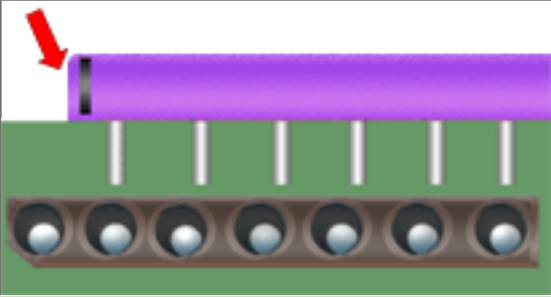
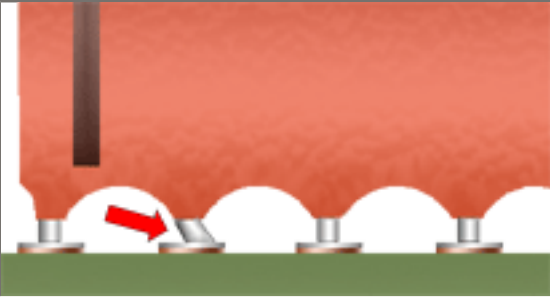
THROUGH-HOLE SOLDERING SINGLE IN-LINE PACKAGE (SIP) (cont.)	
	
<p>ACCEPTABLE TILT</p> <p>The component exhibits minor tilting, but the tilt does not reduce lead protrusion below acceptable minimums, cause the component body to exceed height requirements, or violate minimum electrical spacing requirements.</p> <p>NASA-STD-8739.3 [8.1], [13.6.1]</p>	<p>UNACCEPTABLE EXCESS TILT</p> <p>Excess part tilt causes the leads to not meet minimum protrusion requirements. Excess tilt may cause the part to exceed maximum height requirements, or result in violation of minimum electrical clearance requirements.</p> <p>NASA-STD-8739.3 [13.6.2.a.21]</p>
	
<p>UNACCEPTABLE BENT/CURLED LEAD</p> <p>The lead has been smashed into the pad surface, preventing proper insertion. This may be caused by improper lead planarity, an improperly bent lead, or a solder-plugged hole.</p> <p>NASA-STD-8739.3 [13.6.2.a.7], [13.6.2.a.21]</p>	<p>UNACCEPTABLE IMPROPER ORIENTATION/OFFSET</p> <p>The component has been incorrectly installed, with the chip offset with respect to the intended termination pattern.</p> <p>NASA-STD-8739.3 [13.6.2.a.5]</p>
	

**UNACCEPTABLE
PISTONED LEAD**

The lead has been displaced vertically (pistonned) during insertion. This may be caused by improper lead planarity, an improperly bent lead, or a solder-plugged hole.

[NASA-STD-8739.3 \[13.6.2.a.7\], \[13.6.2.a.21\]](#)

NASA WORKMANSHIP STANDARDS

 NATIONAL AERONAUTICS AND SPACE ADMINISTRATION JOHNSON SPACE CENTER HOUSTON, TEXAS USA 77058	Released: 06.27.2002	Revision:	Revision Date:
	Book: 6	Section: 6.12	Page: 2



[Need a printed copy?](#)
(May take a while to load.)
Requires Adobe Reader.



[Need Adobe Reader?](#)
[Click here to download.](#)



[Questions? Suggestions?](#)

THROUGH-HOLE SOLDERING
TERMINALS

TERMINALS

The proper installation and soldering of wires and component leads to terminals is important to the overall electrical and mechanical reliability of the termination. Particular attention should be paid to routing and stress relief.

See Section 6.01 "Through-Hole Soldering, General Requirements", for common accept/reject criteria.

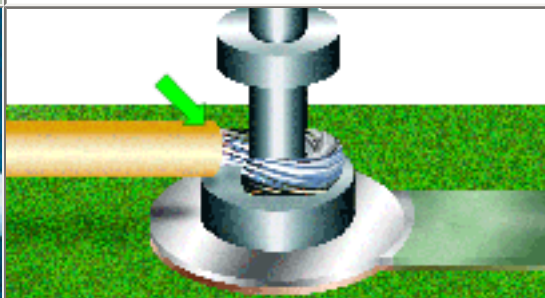
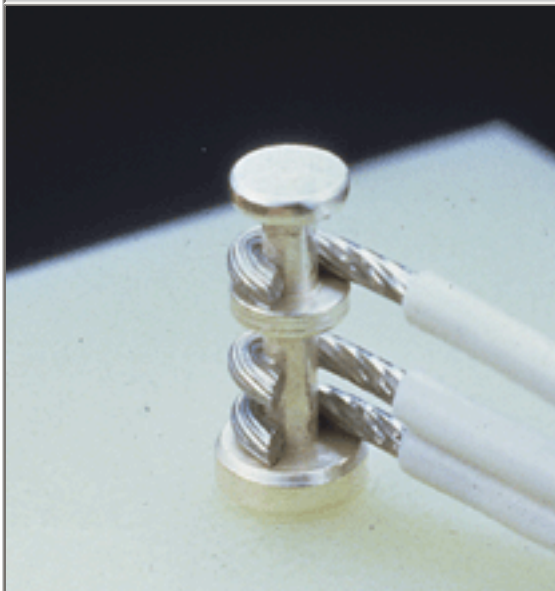

GENERAL REQUIREMENTS
INSULATION GAP

The insulation gap (referenced from the first point of contact of the conductor to the terminal) shall be less than two (2) wire diameters, but shall not be imbedded in the solder joint. The wire contour shall be visible at the end of the insulation.

[NASA-STD-8739.3 \[9.1.1\], \[9.1.2\]](#)

GENERAL REQUIREMENTS
INSULATION GAP (SPECIAL
EXCEPTION)

When characteristic impedance or other circuit parameters may be affected (i.e. high-voltage, high-frequency terminations, etc.), the insulation clearance requirements may be modified. All variations shall be documented.

[NASA-STD-8739.3 \[9.1.4\]](#)

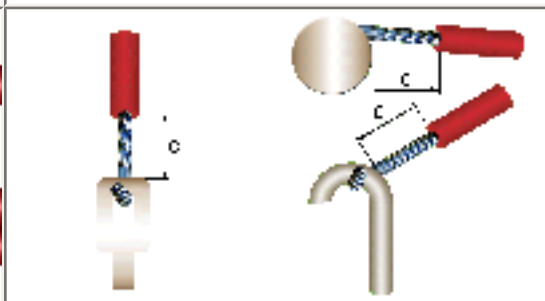
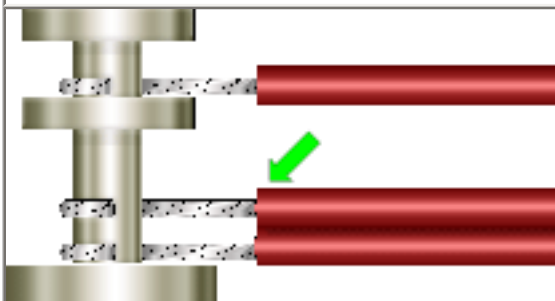

GENERAL REQUIREMENTS
INSULATION GAP
MULTIPLE TERMINATIONS

Conductor insulation clearances are not required to be equal for applications involving the termination of multiple (common) conductors to a terminal in parallel orientation.

[NASA-STD-8739.3 \[9.1.3\]](#)

UNACCEPTABLE
IMPROPER INSULATION GAP (C)

The insulation gap (referenced from the first point of contact of the conductor to the terminal) is greater than two (2) wire diameters. Excessive insulation gap may present a birdcaging or shorting risk.

[NASA-STD-8739.3 \[13.6.2.a.2\]](#)

NASA WORKMANSHIP STANDARDS

Released:
06.27.2002

Revision:

Revision Date:



THROUGH-HOLE SOLDERING TERMINALS (cont.)

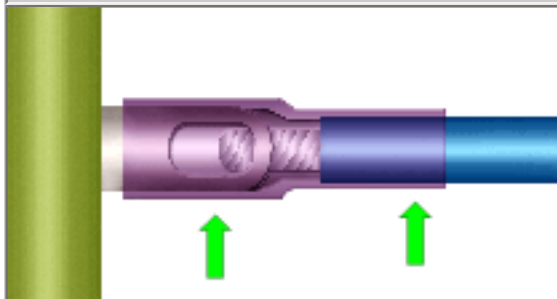

GENERAL REQUIREMENTS
INSULATION SLEEVING

Sleeving shall completely cover and fit snugly around the terminal and the wire insulation and overlap the wire insulation by a minimum of 5 mm (0.20 in.), or two (2) insulated wire diameters, whichever is larger.

[NASA-STD-8739.3 \[9.8\]](#)

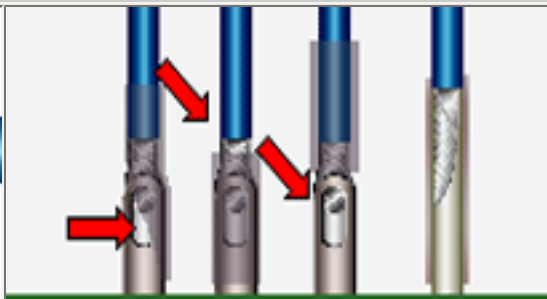

UNACCEPTABLE
IMPROPER INSULATION SLEEVING

The sleeving shall not be pierced, split, charred or otherwise damaged, and shall completely cover the terminal and overlap the wire insulation. The sleeving shall fit snugly around the terminal and the wire insulation.

[NASA-STD-8739.3 \[9.8\]](#)

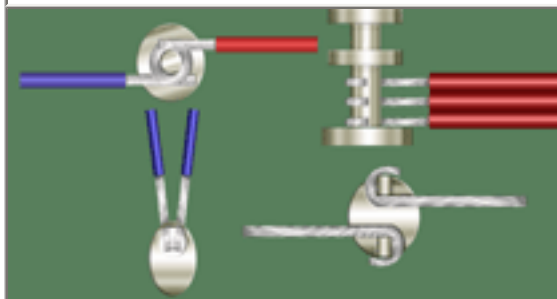

GENERAL REQUIREMENTS
TERMINAL FILL

Conductors shall be in full contact with the terminal and each other. They shall be mounted as close to the base as allowed by the insulation or body shape and not wrapped onto each other or extend beyond the top of the terminal.

[NASA-STD-8739.3 \[9.1.9\]](#)

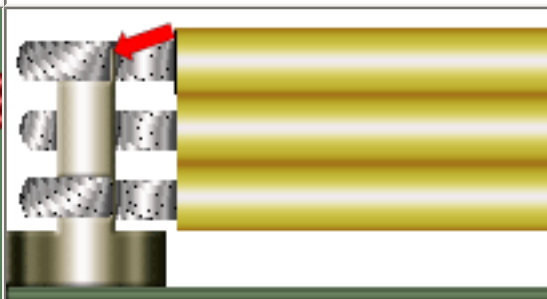

UNACCEPTABLE
EXCESSIVE CONDUCTOR FILL

The number of conductors shall not exceed the capacity of the terminal post. Conductors shall not extend above the top of the terminal post.

[Best Workmanship Practice](#)

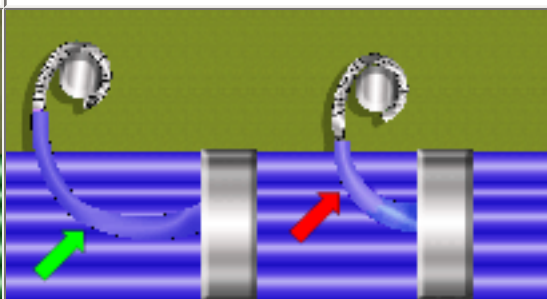
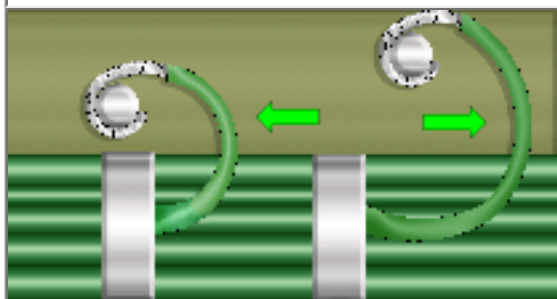

<p>GENERAL REQUIREMENTS SERVICE LOOPS/STRESS RELIEF</p> <p>Wire/harness terminations shall exhibit an even distribution of conductor dress and tension throughout the cable and harness, to prevent stress to the terminations.</p> <p>NASA-STD-8739.3 [9.1.5], [9.1.7], [13.6.1.h] NASA-STD-8739.4 [4.3.5.c], [19.6.1.e.3]</p>	<p>UNACCEPTABLE INSUFFICIENT SERVICE LOOP</p> <p>The termination exhibits an uneven dress length of individual conductors, which may result in a concentration of stress on a single conductor.</p> <p>NASA-STD-8739.3 [13.6.2.a.10], [13.6.2.a.17] NASA-STD-8739.4 [4.3.5.c]</p>
--	--

NASA WORKMANSHIP STANDARDS			
 <p>NATIONAL AERONAUTICS AND SPACE ADMINISTRATION JOHNSON SPACE CENTER HOUSTON, TEXAS USA 77058</p>	Released: 06.27.2002	Revision:	Revision Date:
	Book: 6	Section: 6.13	Page: 2

THROUGH-HOLE SOLDERING TERMINALS (cont.)

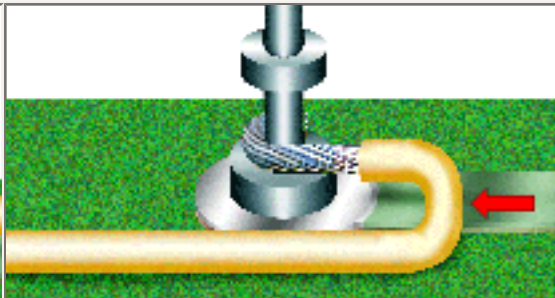
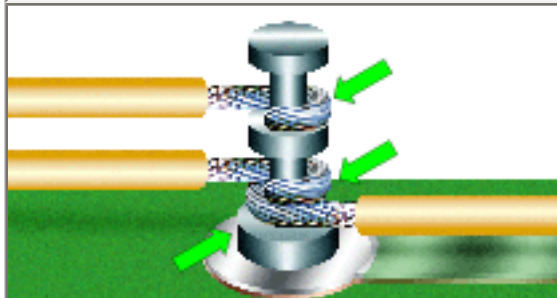

**GENERAL REQUIREMENTS
WRAP ORIENTATION**

Conductors may be wrapped clockwise (CW) or counterclockwise (CCW) to the terminal, but the curvature of dress shall be such that the wrap will tighten against the terminal if the conductor is pulled.

[NASA-STD-8739.3 \[9.1.8\]](#)

**UNACCEPTABLE
IMPROPER WRAP ORIENTATION**

The conductor's curvature and direction of dress are improper, and the wrap will loosen against the terminal if the conductor is pulled. This will eventually weaken the solder joint.

[NASA-STD-8739.3 \[13.6.2.a.10\]](#)

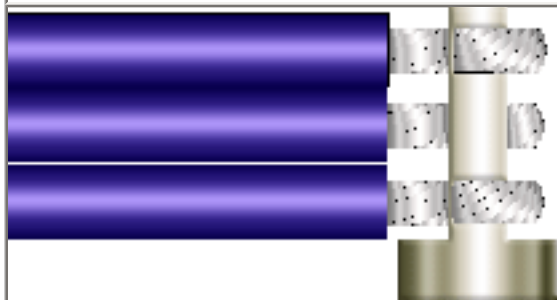

**PREFERRED
BIFURCATED TERMINALS**

Conductors shall enter the slot, perpendicular to the posts, and make positive contact with at least one post corner. Wires shall be placed in ascending order, with largest on the bottom, and wrap directions shall alternate.

[NASA-STD-8739.3 \[9.3.2\]](#)

**PREFERRED
BIFURCATED TERMINALS
SOLDERED ASSEMBLY**

The lead profile is discernible, with wire and terminal interface completely wetted. The solder is smooth and shiny, and fillets the entire wire/lead and terminal interface.

[NASA-STD-8739.3 \[10.2.2\], \[13.6.1\]](#)

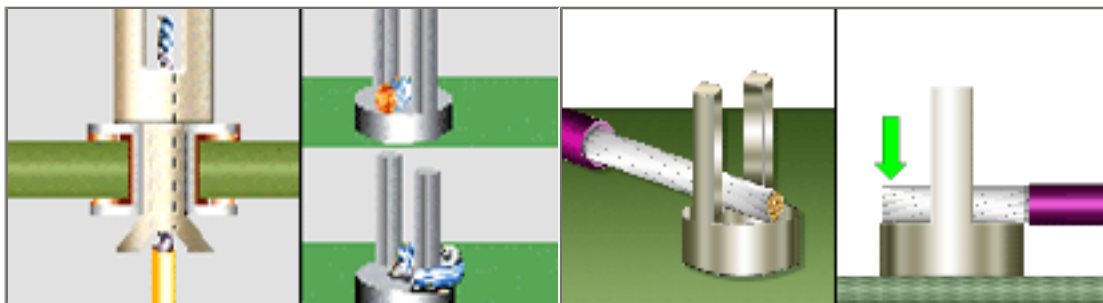

**ACCEPTABLE
BIFURCATED TERMINALS
BOTTOM ROUTE**

The uninsulated conductor end shall enter the terminal from the bottom, be brought through one of the side slots at the top, and wrapped as required for a side route termination.

[NASA-STD-8739.3 \[9.3.3\]](#)

**ACCEPTABLE
BIFURCATED TERMINALS
STRAIGHT-THROUGH TERMINATION**

Single conductors may be terminated straight-through, providing the conductor is in contact with the base, exhibits proper insulation clearance, and has no end overhang.

[NASA-STD-8739.3 \[9.3.2\]](#)

NASA WORKMANSHIP STANDARDS



**NATIONAL AERONAUTICS AND
SPACE ADMINISTRATION
JOHNSON SPACE CENTER
HOUSTON, TEXAS USA 77058**

Released:
06.27.2002

Revision:

Revision Date:

Book:
6

Section:
6.13

Page:
3

**THROUGH-HOLE SOLDERING
TERMINALS (cont.)**

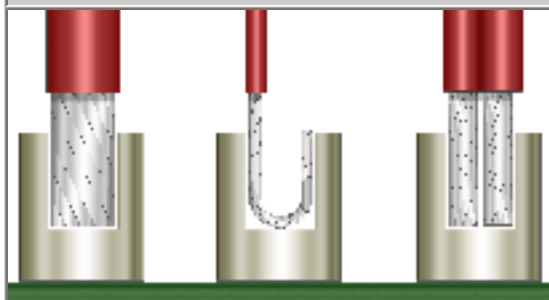

**ACCEPTABLE
BIFURCATED TERMINALS
TOP TERMINATION**

The conductor is in contact with both posts. Any space between the posts has been filled with filler wire or by doubling. **Top termination is not recommended for flight hardware.**

Best Workmanship Practice

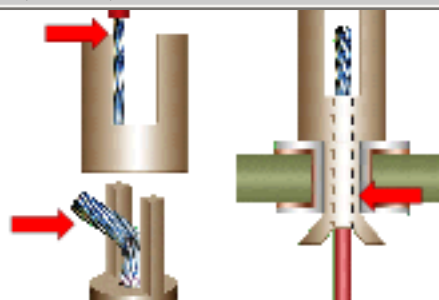



**UNACCEPTABLE
BIFURCATED TERMINALS
TOP ENTRY-PARTIAL FILL**

The top route termination has unfilled space between the posts and the conductor, and no filler wire or doubling has been used to fill the gap.

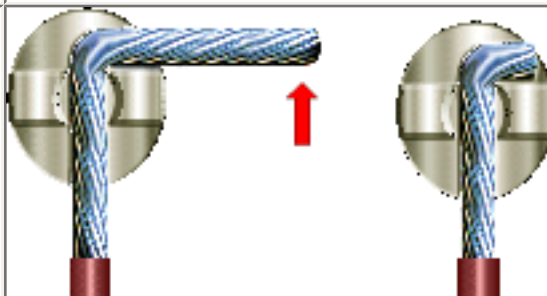
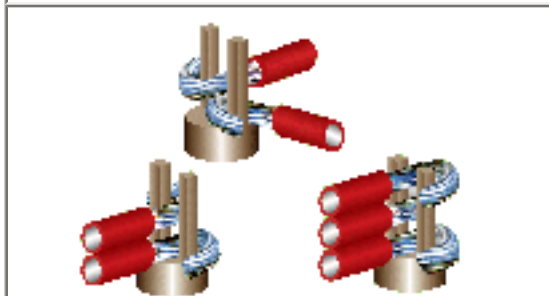
Best Workmanship Practice



<p style="text-align: center;">ACCEPTABLE BIFURCATED TERMINALS WRAP DIRECTION</p> <p>When multiple conductors are connected to a terminal, the direction of bend of each additional conductor shall alternate and the termination shall alternate posts.</p> <p>NASA-STD-8739.3 [9.3.2]</p>	<p style="text-align: center;">UNACCEPTABLE BIFURCATED TERMINALS END TAIL OVERHANG</p> <p>The end tail shall not extend beyond the diameter of the terminal base, except when physical clearance is adequate. End tail overhang may violate minimum electrical clearance.</p> <p>NASA-STD-8739.3 [9.3], [13.6.2.a.10]</p>
	
<p style="text-align: center;">PREFERRED HOOK TERMINALS</p> <p>The conductor is wrapped in full contact with the terminal for a minimum of 180° and a maximum of 270°, and is attached to the hook within the 180° arc. Insulation clearance is less than one (1) wire diameter, and wire end does not protrude.</p> <p>NASA-STD-8739.3 [9.1], [9.4]</p>	<p style="text-align: center;">PREFERRED HOOK TERMINALS COMPLETED ASSEMBLY</p> <p>The lead profile is discernable, with wire and terminal interface completely wetted. The solder is smooth and shiny, and fillets the entire wire/lead and terminal interface.</p> <p>NASA-STD-8739.3 [13.6.1]</p>

NASA WORKMANSHIP STANDARDS			
 <p>NATIONAL AERONAUTICS AND SPACE ADMINISTRATION JOHNSON SPACE CENTER HOUSTON, TEXAS USA 77058</p>	Released: 06.27.2002	Revision:	Revision Date:
	Book: 6	Section: 6.13	Page: 4

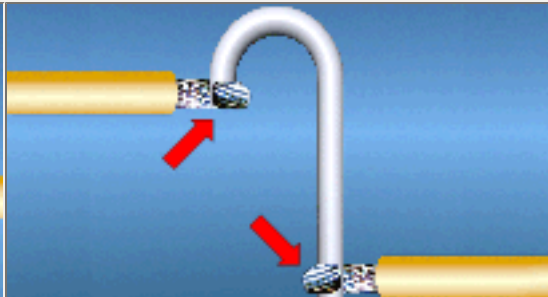
THROUGH-HOLE SOLDERING TERMINALS (cont.)	
	
<p style="text-align: center;">ACCEPTABLE HOOK TERMINALS-WRAP LOCATIONS</p> <p>The conductor(s) are wrapped in full contact for a minimum of 180°. Wraps alternate direction and do not overlap. Terminations are located more than one wire diameter from hook end, with majority located within the 180° arc (hook).</p> <p>NASA-STD-8739.3 [9.4]</p>	<p style="text-align: center;">UNACCEPTABLE HOOK TERMINALS IMPROPER WRAP LOCATION</p> <p>The termination is not located in the 180° arc of the terminal, with the wrap located less than one wire diameter from the hook end.</p> <p>NASA-STD-8739.3 [9.4], [13.6.2.a.10]</p>



**PREFERRED
PIERCED/PERFORATED TERMINAL**

The wire passes through the eye of the terminal, is wrapped in contact with both sides of the terminal, and does not overhang the terminal edge. Insulation clearance is less than 1 wire diameter.

[NASA-STD-8739.3 \[9.5\]](#)

**PREFERRED
PIERCED/PERFORATED TERMINAL
SOLDERED ASSEMBLY**

The lead profile is discernable, with wire and terminal interface completely wetted. The solder is smooth and shiny, and fillets the entire wire/lead and terminal interface.

[NASA-STD-8739.3 \[13.6.1\]](#)

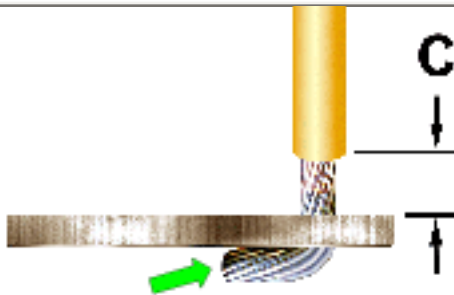

**ACCEPTABLE
PIERCED/PERFORATED TERMINAL
SIDE ENTRY**

The wire passes through the terminal eye, and exhibits a quarter turn (90°) wrap in contact with the terminal face. Termination exhibits proper insulation clearance (C).

[NASA-STD-8739.3 \[9.5\]](#)

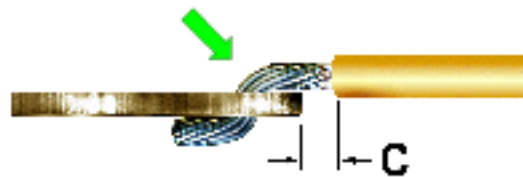

**ACCEPTABLE
PIERCED/PERFORATED TERMINAL
ZIG-ZAG TERMINATION**

The wire passes through the terminal eye and exhibits two (2) quarter turn (90°) zig-zag wraps in contact with both terminal sides. Termination exhibits proper insulation clearance (C).

[NASA-STD-8739.3 \[9.5\]](#)

NASA WORKMANSHIP STANDARDS



**NATIONAL AERONAUTICS AND
SPACE ADMINISTRATION**
JOHNSON SPACE CENTER
HOUSTON, TEXAS USA 77058

Released:
06.27.2002

Revision:

Revision Date:





Book:
6

Section:
6.13

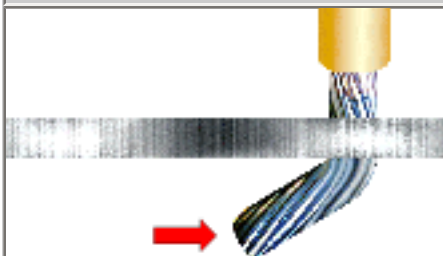
Page:
5

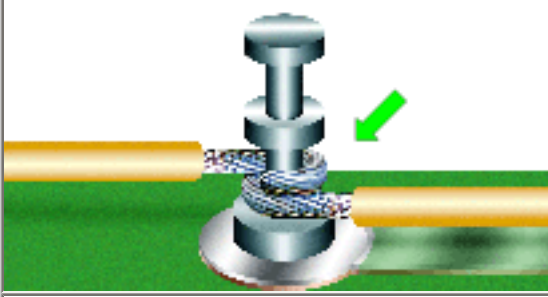
**THROUGH-HOLE SOLDERING
TERMINALS (cont.)**

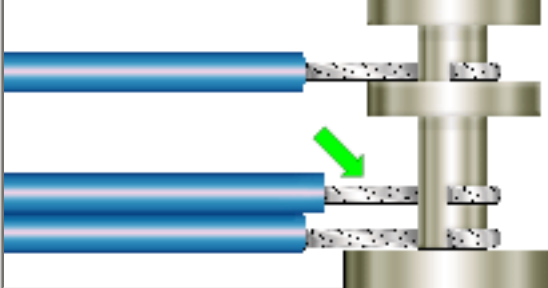
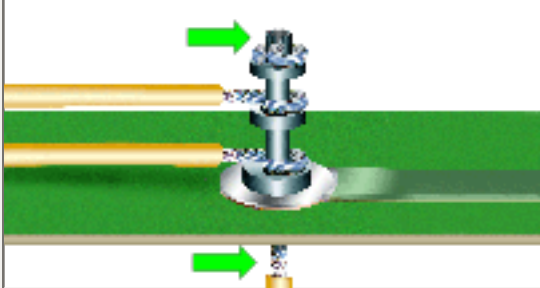

<p style="text-align: center;">UNACCEPTABLE PIERCED/PERFORATED TERMINAL SIDE ENTRY</p> <p>The wire passes through the terminal eye, but exhibits a wrap that is less than 90° and which is not in contact with the terminal face.</p> <p>NASA-STD-8739.3 [9.5], [13.6.2.a.10]</p>	<p style="text-align: center;">UNACCEPTABLE PIERCED/PERFORATED TERMINAL SIDE ENTRY</p> <p>The wire passes through the terminal eye, and exhibits a quarter turn (90°) wrap in contact with the terminal face, extending over the terminal edge.</p> <p>NASA-STD-8739.3 [9.5], [13.6.2.a.10]</p>		
			
<p style="text-align: center;">PREFERRED TURRET TERMINAL</p> <p>The conductors are parallel to each other and to the mounting base. Conductors are mechanically secure, wrapped a minimum of 180° to 360°, non-overlapping, with the first conductor in contact with the terminal base.</p> <p>NASA-STD-8739.3 [9.2]</p>	<p style="text-align: center;">PREFERRED TURRET TERMINAL SOLDERED ASSEMBLY</p> <p>The lead profile is discernable, with wire and terminal interface completely wetted. The solder is smooth and shiny and fillets the entire wire/lead and terminal interface.</p> <p>NASA-STD-8739.3 [10.2.2], [13.6.1.]</p>		
			
<p style="text-align: center;">ACCEPTABLE TURRET TERMINAL</p> <p>Conductors have been mechanically secured to the terminal with a minimum of 180° wraps. Multiple conductors may be installed in a single slot, if wrapped to the post without overlap.</p> <p>NASA-STD-8739.3 [9.2.1]</p>	<p style="text-align: center;">ACCEPTABLE TURRET TERMINALS BOTTOM ROUTE</p> <p>The uninsulated conductor end shall enter the terminal from the bottom, be brought through the side slot at the top, and wrapped as required for a side route termination.</p> <p>NASA-STD-8739.3 [9.2.2]</p>		
 <p>NATIONAL AERONAUTICS AND SPACE ADMINISTRATION JOHNSON SPACE CENTER HOUSTON, TEXAS USA 77058</p>	NASA WORKMANSHIP STANDARDS		
	<p>Released: 06.27.2002</p>	<p>Revision:</p>	<p>Revision Date:</p>
<p>Book: 6</p>	<p>Section: 6.13</p>	<p>Page: 6</p>	

THROUGH-HOLE SOLDERING
TERMINALS (cont.)

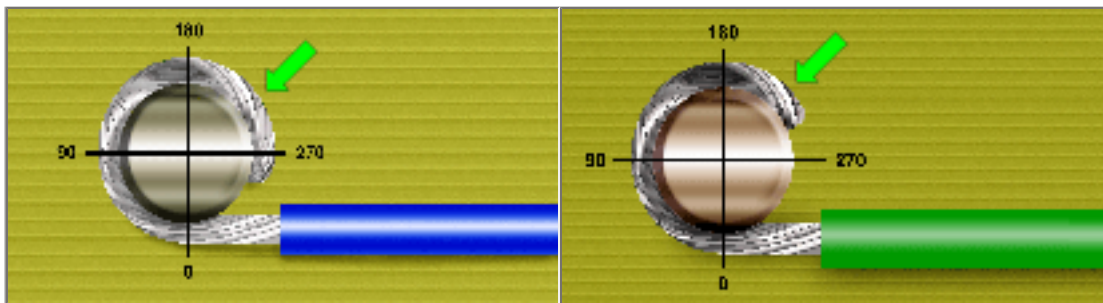

**MANDATORY
TURRET TERMINAL WRAP
CONDUCTOR SIZES \leq AWG 26**

Conductor sizes AWG 26 and smaller shall be wrapped a minimum of 1/2 turn (180°), but less than one (1) full turn (360°) around the post.

[NASA-STD-8739.3 \[9.2.1.b\]](#)

**MANDATORY
TURRET TERMINAL WRAP
CONDUCTOR SIZES $>$ AWG 26**

Conductor sizes larger than AWG 26 shall be wrapped a minimum of 1/2 turn (180°), to a maximum of 3/4 turn (270°) around the post.

[NASA-STD-8739.3 \[9.2.1.a\]](#)

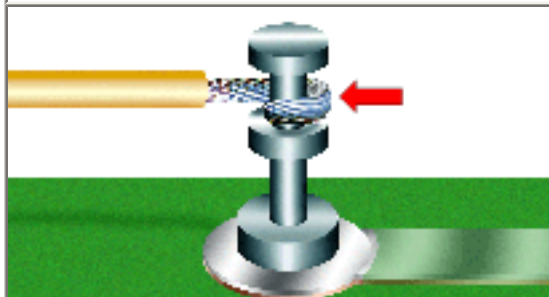

**UNACCEPTABLE
TURRET TERMINALS
IMPROPER WRAP**

Conductors and part leads shall be mounted as close to the terminal base, as allowed by the insulation or body shape, and shall be in full contact with the terminal and each other.

[NASA-STD-8739.3 \[9.1\]](#), [\[13.6.2.a.10\]](#)

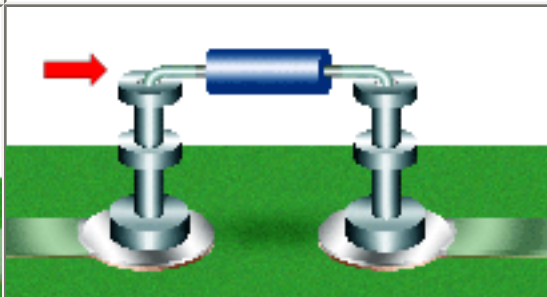

**UNACCEPTABLE
TURRET TERMINALS
TOP MOUNTING**

Components shall be mounted parallel and in contact with the mounting surface, unless specified otherwise in the engineering documentation.

[NASA-STD-8739.3 \[8.3.1\]](#), [\[13.6.2.a.5\]](#)

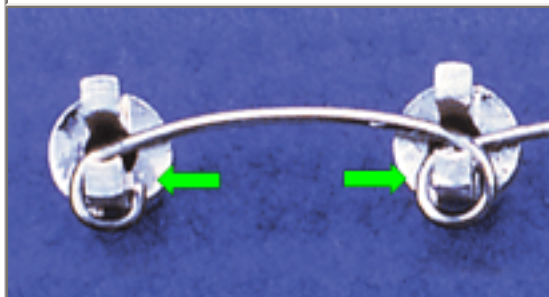

**SPECIAL APPLICATIONS
CONTINUOUS RUN CONNECTIONS
BIFURCATED TERMINALS**

The wire shall pass between each set of terminal posts, contact each terminal base, and exhibit stress relief. The wire ends shall be attached to the first and last terminal with a 90° to 180° wrap.

[NASA-STD-8739.3 \[9.3.4\]](#)

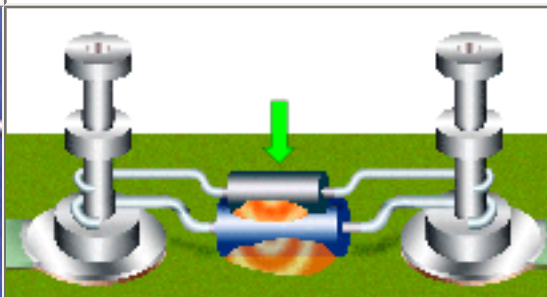

**SPECIAL APPLICATIONS
PIGGYBACKED/STACKED COMPONENTS**

Multiple discrete components may be terminated in a piggybacked/stacked configuration, with the largest component mounted parallel to and in contact with the mounting surface. All components shall be stress-relieved and staked.

[Best Workmanship Practice](#)

NASA WORKMANSHIP STANDARDS



**NATIONAL AERONAUTICS AND
SPACE ADMINISTRATION
JOHNSON SPACE CENTER
HOUSTON, TEXAS USA 77058**

Released:
06.27.2002

Revision:

Revision Date:

Book:
6

Section:
6.13

Page:
7

THROUGH-HOLE SOLDERING TERMINALS (cont.)	
<p>SPECIAL APPLICATIONS CONTINUOUS RUN CONNECTIONS PIERCED/PERFORATED TERMINALS</p> <p>The wire shall pass through each terminal eye, contacting both sides of each terminal, exhibit stress relief, and shall be terminated to the first and last terminal with a 90° to 180° wrap.</p> <p>Best Workmanship Practice</p>	<p>UNACCEPTABLE</p> <p>CONTINUOUS RUN CONNECTIONS PIERCED/PERFORATED TERMINALS</p> <p>The wire passes through each terminal eye, but does not contact both sides of each terminal.</p> <p>Best Workmanship Practice</p>
<p>SPECIAL APPLICATIONS CONTINUOUS RUN CONNECTIONS TURRET TERMINALS</p> <p>The wire shall wrap around each terminal, contact each terminal base, exhibit stress relief, and be terminated to the first and last terminal with a 180° to 270° wrap (depending on wire gauge).</p> <p>NASA-STD-8739.3 [9.2.3]</p>	<p>UNACCEPTABLE</p> <p>CONTINUOUS RUN CONNECTIONS TURRET TERMINALS</p> <p>The wire does not wrap 360° around each inner terminal or exhibit sufficient stress relief.</p> <p>NASA-STD-8739.3 [9.2.3]</p>

NASA WORKMANSHIP STANDARDS			
	<p>NATIONAL AERONAUTICS AND SPACE ADMINISTRATION</p>	<p>Released: 06.27.2002</p>	<p>Revision:</p>
	<p>JOHNSON SPACE CENTER HOUSTON, TEXAS USA 77058</p>	<p>Book: 6</p>	<p>Section: 6.13</p>



[Need a printed copy?](#)
(May take a while to load.)
Requires Adobe Reader.



[Need Adobe Reader?](#)
[Click here to download.](#)



[Questions? Suggestions?](#)

**THROUGH-HOLE SOLDERING
SOLDER CUPS**



SOLDER CUPS

Solder cup terminals are primarily designed for the in-line solder termination of conductors. This style of terminal is principally designed as a precision-machined pin for insertion into connector bodies.

Variations include connectors in which the solder cup pin is captive in the connector body (i.e.: hermetic connectors), or printed wiring board mounted terminals designed for discrete wire terminations.

See Section 6.01 "Through-Hole Soldering, General Requirements", for common accept/reject criteria.

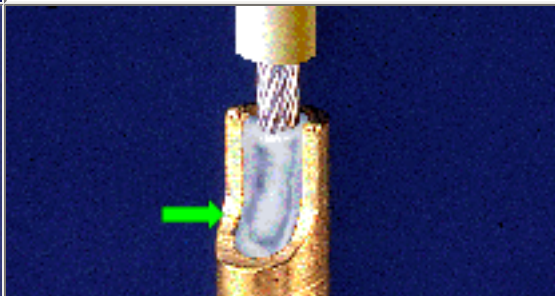
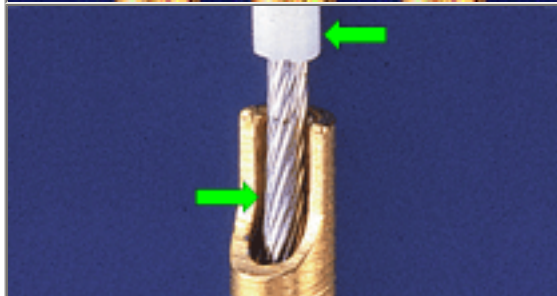

**PREFERRED
INTERIM ASSEMBLY**

The wire has been inserted straight into the cup, is in contact with the back wall for the full depth of the cup and bottoms in the cup. The assembly exhibits proper insulation gap and the cup interior has been pretinned.

[NASA-STD-8739.3 \[9.6\]](#)

**PREFERRED
COMPLETED ASSEMBLY**

The solder shall form a fillet between the conductor and the cup entry slot, and shall follow the contour of the cup opening.

[NASA-STD-8739.3 \[10.2.3\]](#)

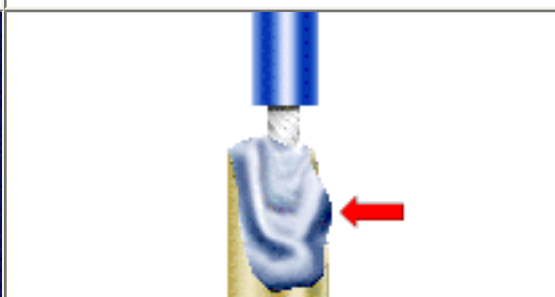
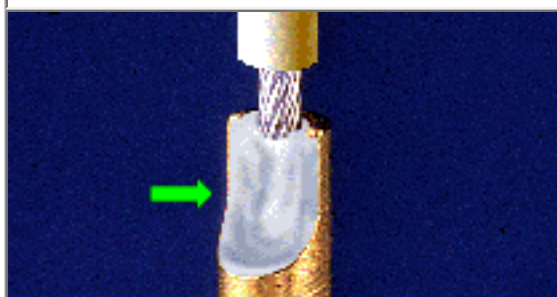

**ACCEPTABLE
MAXIMUM SOLDER**

The solder quantity is the maximum acceptable, but does not spill over (exceed the diameter of the cup), or exhibit a convex profile.

[NASA-STD-8739.3 \[10.2.3.b\]](#)

**UNACCEPTABLE
EXCESS SOLDER**

The solder does not follow the contour of the cup opening and spills over (exceeds the diameter of the cup) with a convex profile.

[NASA-STD-8739.3 \[10.2.3.a\]](#), [\[13.6.2.b.6\]](#)

NASA WORKMANSHIP STANDARDS

	Released: 06.27.2002	Revision:	Revision Date:
--	-------------------------	-----------	----------------



THROUGH-HOLE SOLDERING
 SOLDER CUPS (cont.)

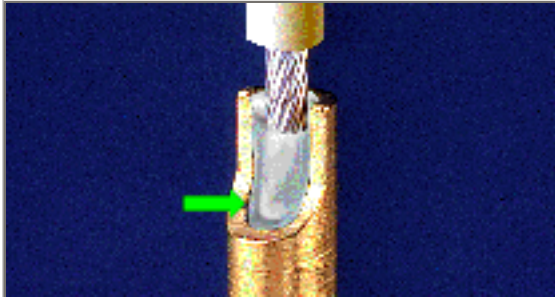

**ACCEPTABLE
 MINIMUM SOLDER**

The solder quantity is sufficient to follow the contour of the cup opening. The termination is fully wetted with complete, slightly concave, fillets between the wire and the cup wall. Solder fill is at least 75%.

[NASA-STD-8739.3 \[10.2.3.a\]](#)



**UNACCEPTABLE
 INSUFFICIENT SOLDER QUANTITY**

The solder quantity is insufficient to follow the contour of the cup opening. The termination is fully wetted, but exhibits incomplete fillets along the conductor. Solder surface is not visible in bottom of cup.

[NASA-STD-8739.3 \[10.2.3.a\], \[13.6.2.b.7\]](#)

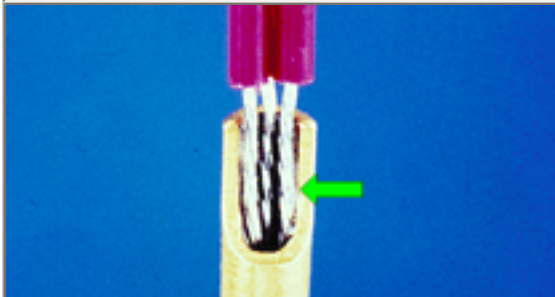

**ACCEPTABLE
 MULTIPLE TERMINATIONS**

The maximum number of conductors that can be inserted into the cup is limited to those that can be in contact with the full height of the back wall of the cup. All wires shall exhibit proper insulation gaps, but do not need to exhibit equal gaps.

[NASA-STD-8739.3 \[9.6\]](#)

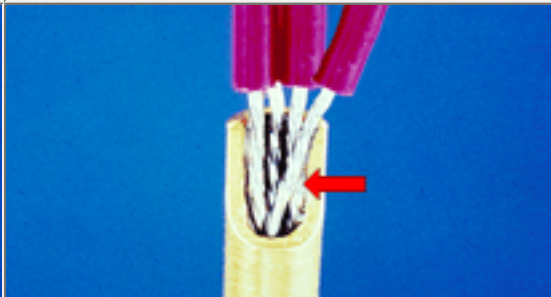

**UNACCEPTABLE
 EXCESSIVE CONDUCTORS**

The number of conductors inserted exceeds the number than can be in contact with the full height of the back wall of the cup.

[NASA-STD-8739.3 \[9.6\]](#)

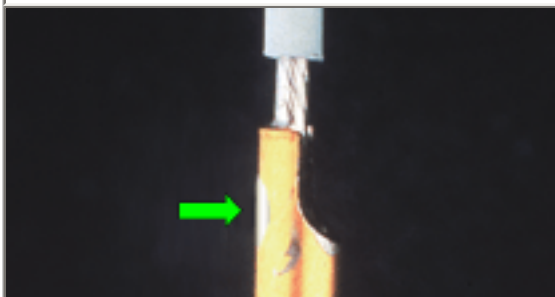

<p>ACCEPTABLE SPILLAGE</p> <p>Solder along the outside of the cup (spillage) is acceptable, provided the solder deposit approximates tinning and does not interfere with the form, fit or function of the connector.</p> <p>NASA-STD-8739.3 [10.2.3.b]</p>	<p>UNACCEPTABLE SPILLAGE</p> <p>The solder deposit interferes with the form, fit or function of the connector.</p> <p>NASA-STD-8739.3 [10.2.3.b], [13.6.2.b.6]</p>
---	---

NASA WORKMANSHIP STANDARDS			
 <p>NATIONAL AERONAUTICS AND SPACE ADMINISTRATION JOHNSON SPACE CENTER HOUSTON, TEXAS USA 77058</p>	Released:	Revision:	Revision Date:
	06.27.2002		
	Book:	Section:	Page:
	6	6.14	2

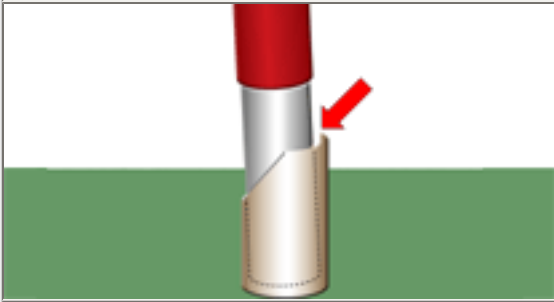
THROUGH-HOLE SOLDERING SOLDER CUPS (cont.)	
	
<p>UNACCEPTABLE IMPROPER INSTALLATION</p> <p>The wire has been inserted for the full depth, but is not in contact with the back wall of the cup.</p> <p>NASA-STD-8739.3 [9.6], [13.6.2.a.5]</p>	

 NATIONAL AERONAUTICS AND SPACE ADMINISTRATION JOHNSON SPACE CENTER HOUSTON, TEXAS USA 77058	Released: 06.27.2002	Revision:	Revision Date:
	Book: 6	Section: 6.14	Page: 3



[Need a printed copy?](#)
(May take a while to load.)
Requires Adobe Reader.



[Need Adobe Reader?](#)
[Click here to download.](#)

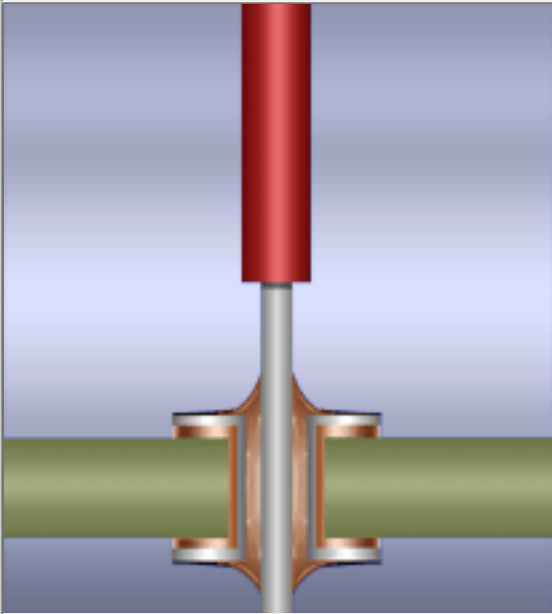
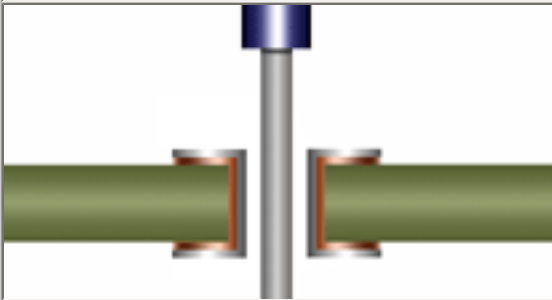
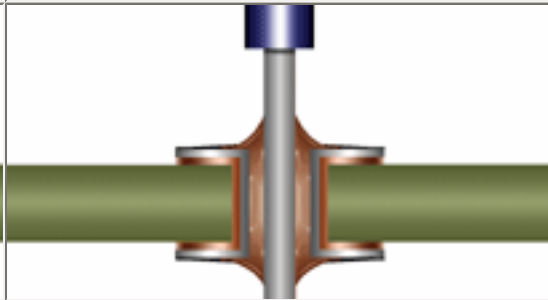
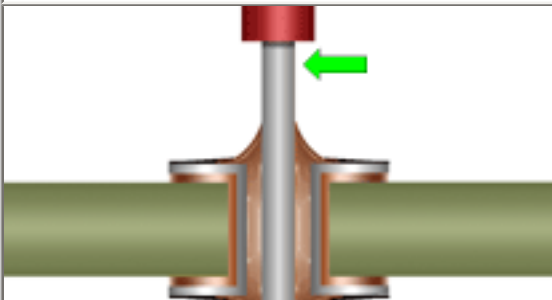
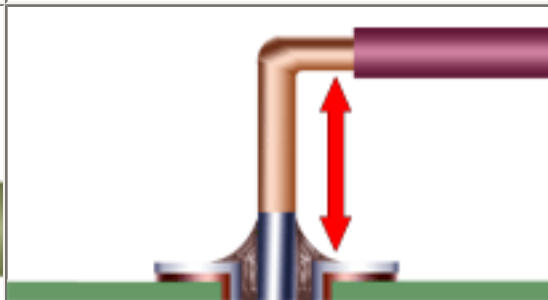

[Questions? Suggestions?](#)

THROUGH-HOLE SOLDERING DISCRETE WIRES		
	<p align="center">DISCRETE WIRES</p> <p>Designs often require the termination of discrete conductors directly to the printed wiring board, rather than to terminal posts or through a connector. Terminations are typically through-hole, but lap terminations are also possible.</p> <p>All discrete wires are considered to be components - with the same bending, soldering and stress relief requirements seen for other discrete axial/radial devices.</p> <p>See Section 6.01 "Through-Hole Soldering, General Requirements", for common accept/reject criteria.</p>	
		
<p align="center">PREFERRED THROUGH-HOLE TERMINATION INTERIM ASSEMBLY</p> <p>The conductor enters the hole, perpendicular to the board surface, and exhibits proper insulation clearance and lead protrusion. The wire end may be clinched to aid assembly. NASA-STD-8739.3 [8.4]</p>	<p align="center">PREFERRED THROUGH-HOLE TERMINATION FINAL ASSEMBLY</p> <p>The termination exhibits proper insulation clearance and lead protrusion. The termination is fully wetted, with complete fillet formation on both sides of the board. NASA-STD-8739.3 [8.4]</p>	
		
<p align="center">ACCEPTABLE INSULATION GAP</p> <p>The insulation gap (referenced from the first point of contact of the conductor to the terminal) shall be less than two (2) wire diameters, but shall not be imbedded in the solder joint. The wire contour shall be visible at the end of the insulation. NASA-STD-8739.3 [9.1.1], [9.1.2]</p>	<p align="center">UNACCEPTABLE EXCESSIVE INSULATION GAP</p> <p>The insulation gap exceeds the maximum of two (2) insulated wire diameters, and may present a shorting or birdcaging potential. NASA-STD-8739.3 [9.1.1], [13.6.2.a.2]</p>	
NASA WORKMANSHIP STANDARDS		
<p>Released: 06.27.2002</p>	<p>Revision:</p>	<p>Revision Date:</p>



THROUGH-HOLE SOLDERING DISCRETE WIRES (cont.)

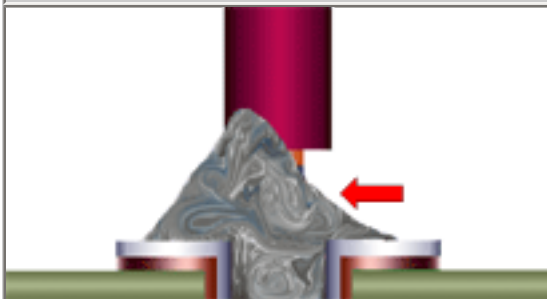

UNACCEPTABLE
INSUFFICIENT INSULATION GAP

The insulation is imbedded in the solder joint and the contour of the conductor is not visible.

[NASA-STD-8739.3 \[9.1.1\], \[13.6.2.a.2\]](#)

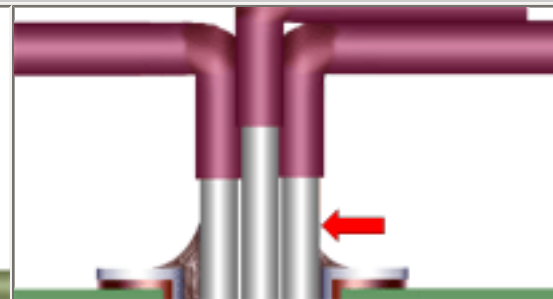

UNACCEPTABLE
MULTIPLE CONDUCTORS

No more than one conductor shall be inserted into any one hole, unless specified on the engineering documentation.

[Best Workmanship Practice](#)

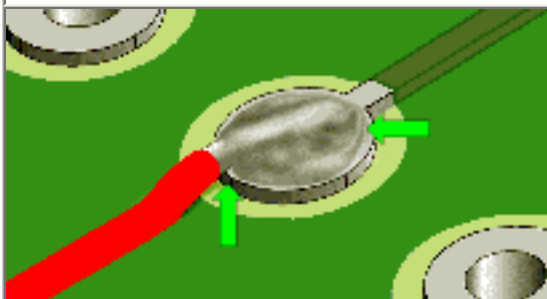

ACCEPTABLE
LAPPED TERMINATION

The termination shall be parallel to the longest dimension of the pad, and exhibit a complete solder fillet around all sides of the lead. The conductor shall not exhibit end overhang. A heel fillet is mandatory.

[NASA-STD-8739.3 \[11.2.5\]](#)



UNACCEPTABLE
IMPROPER LAP TERMINATION

The lap termination shall not overhang the land edge and/or violate minimum electrical spacing.

[Best Workmanship Practice](#)

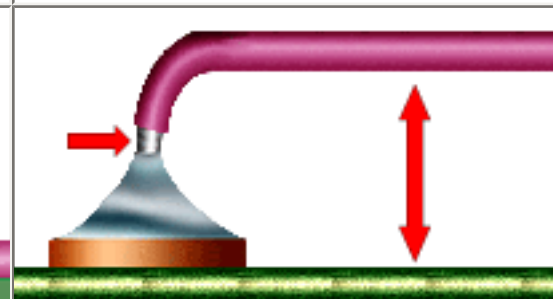
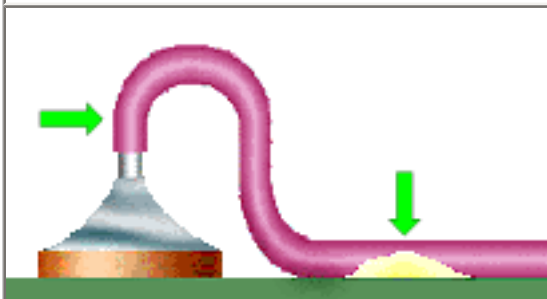

<p>ACCEPTABLE STRAIN RELIEF</p> <p>Stress relief shall be incorporated, wherever possible, into all leads and conductors terminating in solder connections to provide freedom of movement of part leads or conductors between points of constraint.</p> <p>NASA-STD-8739.3 [8.1.1], [8.1.5]</p>	<p>UNACCEPTABLE IMPROPER STRAIN RELIEF</p> <p>The termination does not exhibit an acceptable strain relief bend and is not properly staked. There is a potential for any pulling stress to transfer to the solder joint (note the termination is lightly bent) and eventual fracture fatigue.</p> <p>NASA-STD-8739.3 [8.1.1], [13.6.2.a.10]</p>
--	--

NASA WORKMANSHIP STANDARDS			
 <p>NATIONAL AERONAUTICS AND SPACE ADMINISTRATION JOHNSON SPACE CENTER HOUSTON, TEXAS USA 77058</p>	Released: 06.27.2002	Revision:	Revision Date:
	Book: 6	Section: 6.15	Page: 2







[Need a printed copy?](#)
(May take a while to load.)
Requires Adobe Reader.



[Need Adobe Reader?](#)
[Click here to download.](#)

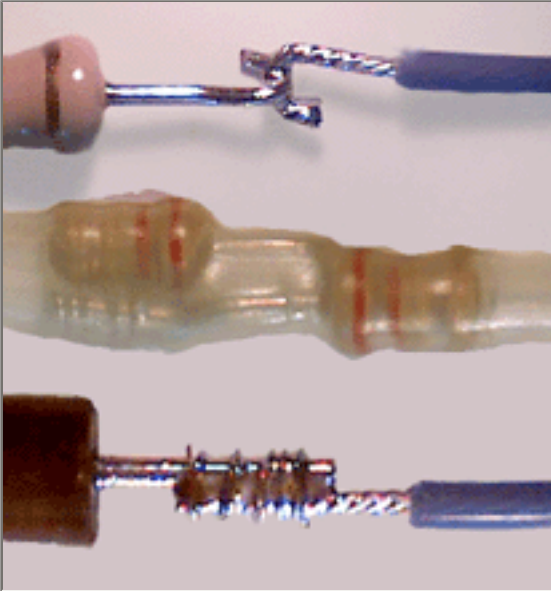
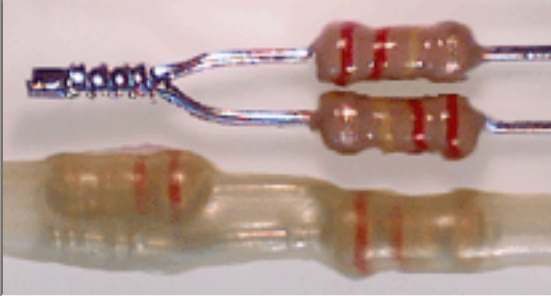

[Questions? Suggestions?](#)

THROUGH-HOLE SOLDERING SERVICE LEAD SPLICES		
		<p>SERVICE LEAD SPLICES</p> <p>Design applications may require the termination of a discrete leaded component in a non-standard configuration, where the components are not terminated in the manner originally designed for the package type, the component's leads are being used as terminals, and/or where the termination method is not addressed in the NASA standards.</p> <p>These terminations impose stress relief requirements on the solder joint and the component lead seals that must be addressed to ensure reliable operation.</p>
		
<p>PREFERRED END SPLICE</p> <p>The end splice is a version of the lash splice, where the conductor ends are laid side by side, wrapped, soldered, and then insulated with shrink tubing. For inline configurations, the splice section may be bent back against the larger conductor(s) and sleeved for strain-relief.</p>	<p>PREFERRED GROUND LEAD/DRAIN WIRE SPLICE</p> <p>The lash splice can be used to attach a ground lead/drain wire to a shielded cable in instances where a solder sleeve is impractical or too bulky. Assembly rating: Easy/Moderate</p>	
		
<p>PREFERRED HOOK SPLICE</p> <p>This splice is typically used to terminate discrete, leaded components in "daisy-chain" configurations. The termination has good tensile properties, but is prone to solder joint fatigue if repeatedly flexed. Assembly rating: Easy</p>	<p>PREFERRED LAP SPLICE</p> <p>A lap splice is a non-structural splice, where the component lead end and the conductor end are soldered in parallel, overlapping contact to each other. The splice may be simple or complex, and is more compact than a solder sleeve. Assembly rating: Easy</p>	
NASA WORKMANSHIP STANDARDS		
	Released: 06.27.2002	Revision: Revision Date:



THROUGH-HOLE SOLDERING
 SERVICE LEAD SPLICES (cont.)



PREFERRED
 LASH SPLICE

A lash splice is a structural splice, consisting of a lap splice with a single strand overlap winding mechanically binding the lead and conductor together. The splice may be simple or complex, and is more compact than a solder sleeve.

Assembly rating: Easy/Moderate

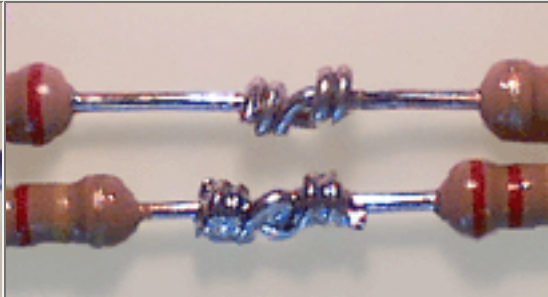

PREFERRED
 LINEMAN/WESTERN UNION SPLICE

This splice is best suited for the termination of wire and cable, but can be used for the termination of discrete component leads. The splice is suitable for situations where the termination may be subjected to tensile loading.

Assembly: Difficult



PREFERRED
 MAGNET WIRE SPLICE

After stripping and preparing for soldering, the ends of the wires shall be twisted together a minimum of three turns in an end slice configuration, soldered and insulated. The splice section shall be bent back against the larger conductor and strain-relieved.



PREFERRED
 SOLDER SLEEVES

Originally developed for the termination of cable shield drain wires, solder sleeves produce a one-step, insulated and sealed splice. Solder sleeves are typically larger than that achievable with a lap or lash splice.

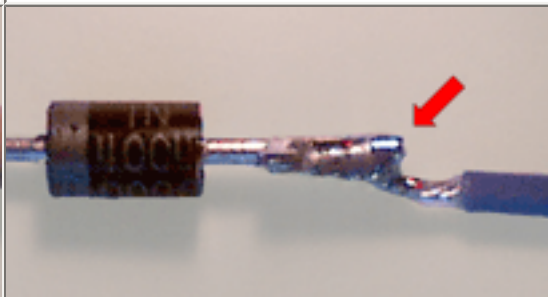
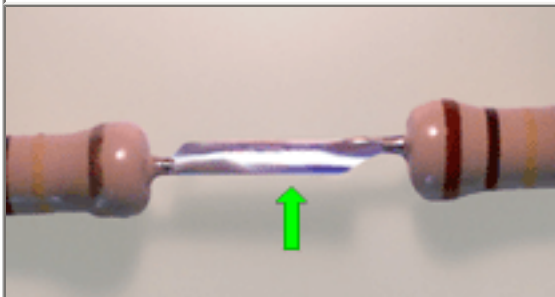

<p style="text-align: center;">ACCEPTABLE ANGULAR ALIGNMENT (LAP/LASH)</p> <p>Angular misalignment of less than 2 lead diameters (measured at the conductor ends of the splice section) is allowable, provided there are no protruding or sharp edges.</p> <p>Best Workmanship Practice</p>	<p style="text-align: center;">UNACCEPTABLE LEAD/CONDUCTOR MISALIGNMENT</p> <p>Angular misalignment in excess of 2 lead diameters (measured at the conductor ends of the splice section) produces a mechanically weak solder joint, with protruding ends or sharp edges.</p> <p>Best Workmanship Practice</p>
--	--

NASA WORKMANSHIP STANDARDS			
 <p>NATIONAL AERONAUTICS AND SPACE ADMINISTRATION JOHNSON SPACE CENTER HOUSTON, TEXAS USA 77058</p>	Released: 06.27.2002	Revision:	Revision Date:
	Book: 6	Section: 6.16	Page: 2

THROUGH-HOLE SOLDERING SERVICE LEAD SPLICES (cont.)

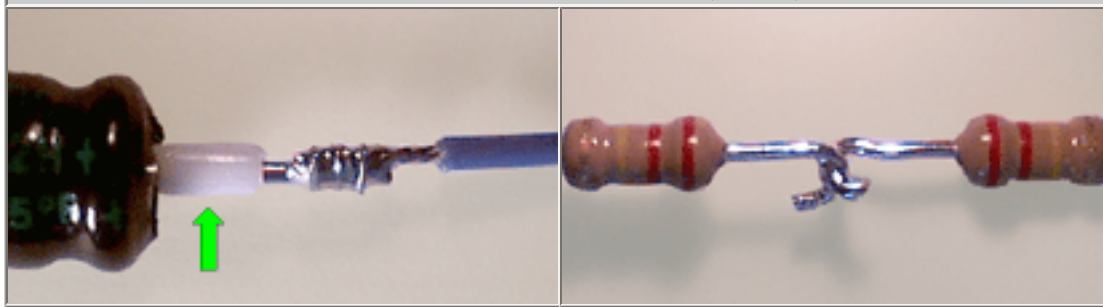

ACCEPTABLE
COMPONENT LEAD INSULATION

The component lead shall be sleeved with tubing, between the lead seal/weld bead to within 2 lead diameters of the solder joint (if applicable).

[Best Workmanship Practice](#)

ACCEPTABLE
DAISY-CHAIN

The components exhibit acceptable solder terminations and are sleeved to provide strain relief.

[Best Workmanship Practice](#)

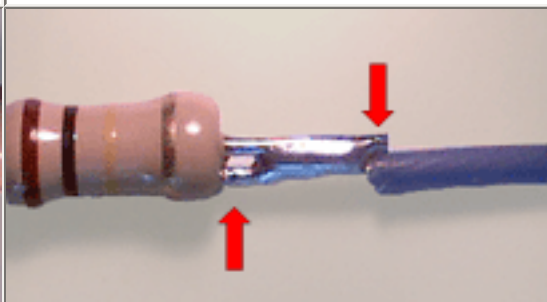
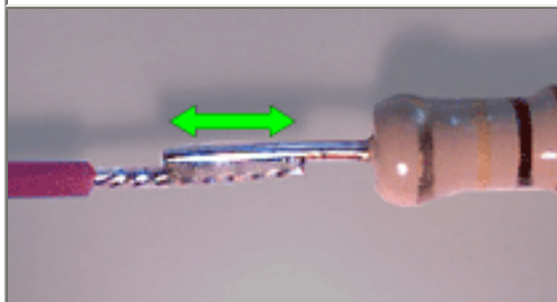

ACCEPTABLE
CONDUCTOR OVERLAP (LAP/LASH)

The conductors in the splice section shall be in parallel, overlapping contact to each other. The solder section shall be a minimum of 5-8 mm (0.2 - 0.3 in.) in length.

[Best Workmanship Practice](#)

UNACCEPTABLE
EXCESSIVE OVERLAP

The soldered section shall be a minimum of 5-8 mm (0.2 - 0.3 in.) in length, but should not contact the insulation jacket(s) or the lead seal/weld bead. Excessive overlap increases stress on the component lead and body seal/weld bead.

[Best Workmanship Practice](#)

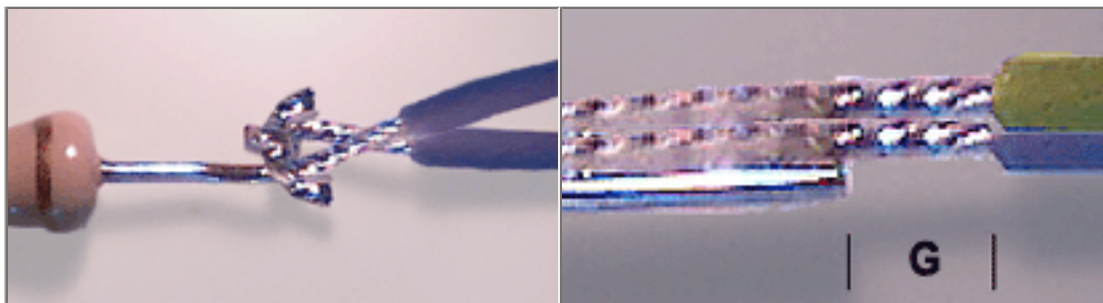

**ACCEPTABLE
HOOK SPLICE ORIENTATION**

The conductor and the component lead shall be aligned approximately 90° to, and in contact with, each other. In multiple conductor configurations, the direction of each additional conductor wrap shall be alternated, and shall not overlap.

[Best Workmanship Practice](#)

**ACCEPTABLE
INSULATION GAP**

The conductor(s) shall exhibit proper insulation spacing. In multiple conductor configurations, the conductor insulation gaps shall be approximately equal.

[NASA-STD-8739.3 \[9.1.1\], \[9.1.2\]](#)

[NASA-STD-8739.4 \[10.1.7.a\]](#)

NASA WORKMANSHIP STANDARDS



**NATIONAL AERONAUTICS AND
SPACE ADMINISTRATION**
JOHNSON SPACE CENTER
HOUSTON, TEXAS USA 77058

Released:
06.27.2002

Revision:

Revision Date:

Book:
6

Section:
6.16

Page:
3

**THROUGH-HOLE SOLDERING
SERVICE LEAD SPLICES (cont.)**



**ACCEPTABLE
INSULATION SLEEVING APPLICATION**

The completed solder joint shall be over-sleeved with transparent/translucent heat shrink tubing of sufficient length to cover the solder joint and extend over the insulation of each conductor a minimum of 5 mm (0.20 in.).

[Best Workmanship Practice](#)





**UNACCEPTABLE
EXPOSED TERMINATION**

The shrink tubing has been properly installed, resulting in exposure of the conductive surface. The tubing should be of sufficient length to cover the solder joint and extend over the insulation of each conductor a minimum of 5 mm (0.20 in.).

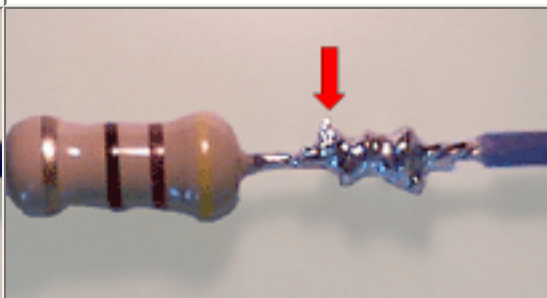
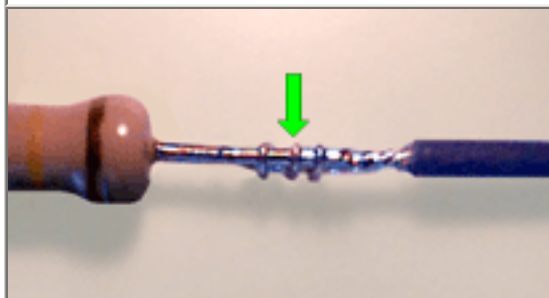

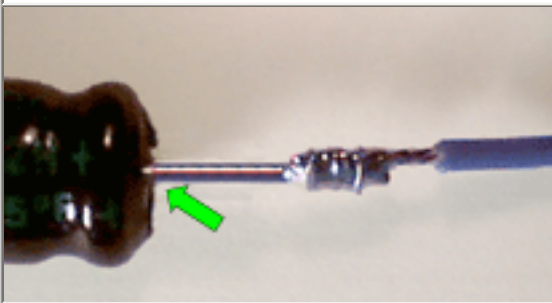
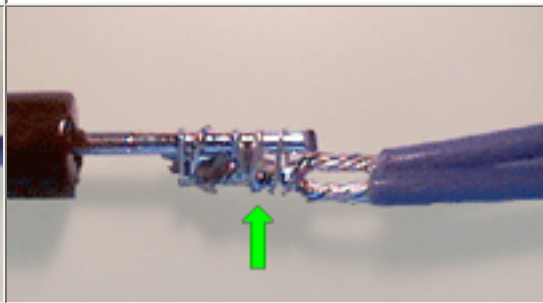
[Best Workmanship Practice](#)

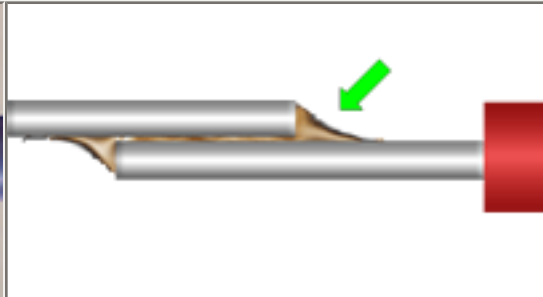

<p style="text-align: center;">ACCEPTABLE LASH WINDING</p> <p>The lash shall consist of a tinned, solid 34 AWG (or smaller) conductor, tightly wrapped in an open spiral of approximately 4-6 complete, non-overlapping turns, approximately centered over the splice. Lash ends shall be trimmed flush.</p> <p>Best Workmanship Practice</p>	<p style="text-align: center;">UNACCEPTABLE IMPROPER LASH/WRAP</p> <p>The lash has been completed with a conductor the same gage as the mated conductors, resulting in an insufficient number of wraps to achieve a secure mechanical termination.</p> <p>Best Workmanship Practice</p>
	
<p style="text-align: center;">ACCEPTABLE LEAD SEAL/WELD BEAD SPACING</p> <p>The component end of the solder joint shall not be closer than 2 lead diameters or 0.50 mm (0.020 in.), whichever is larger, from the lead seal/weld bead.</p> <p>Best Workmanship Practice</p>	<p style="text-align: center;">ACCEPTABLE MULTIPLE/COMPLEX CONFIGURATIONS</p> <p>In multiple conductor configurations, the conductor ends may be twisted together, with the twisted section parallel to, and in contact with, the component lead.</p> <p>Best Workmanship Practice</p>

NASA WORKMANSHIP STANDARDS			
	<p>NATIONAL AERONAUTICS AND SPACE ADMINISTRATION</p>	<p>Released: 06.27.2002</p>	<p>Revision:</p>
	<p>JOHNSON SPACE CENTER HOUSTON, TEXAS USA 77058</p>	<p>Book: 6</p>	<p>Section: 6.16</p>

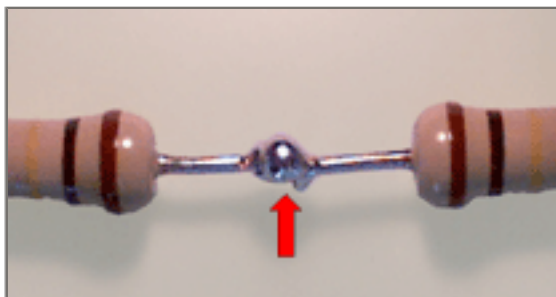
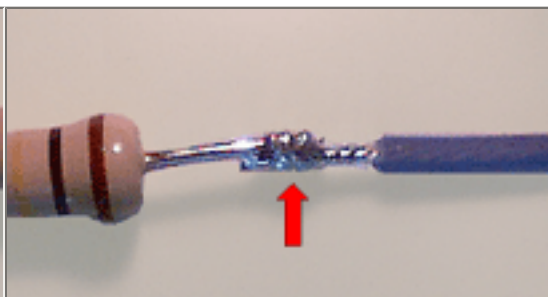
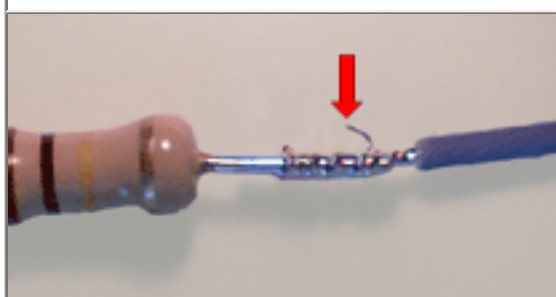
THROUGH-HOLE SOLDERING SERVICE LEAD SPLICES (cont.)	
	
<p style="text-align: center;">ACCEPTABLE SERVICE LEAD</p> <p>The service lead conductor(s) shall be insulated stranded wire, unless otherwise specified in the engineering documentation.</p> <p>Best Workmanship Practice</p>	<p style="text-align: center;">ACCEPTABLE SOLDER FILLET</p> <p>The solder joint shall comply with all the basic requirements of NASA-STD-8739.3 for a solder termination. The termination shall be fully wetted, with a smooth, shiny, concave fillet. The contour of the lead and conductor shall be discernable.</p> <p>NASA-STD-8739.3 [13.6]</p>

	
<p style="text-align: center;">UNACCEPTABLE BUTT SOLDER JOINT</p> <p>Butt solder terminations shall not be used. Best Workmanship Practice</p>	<p style="text-align: center;">UNACCEPTABLE INSUFFICIENT OVERLAP</p> <p>The soldered section shall be a minimum of 5-8 mm (0.2 - 0.3 in.) in length to ensure the formation of a proper solder fillet, especially if a lap termination is used. Best Workmanship Practice</p>
	
<p style="text-align: center;">UNACCEPTABLE PROTRUDING LASH END</p> <p>The end of the lash winding has not been properly trimmed, creating a potential short circuit problem. Best Workmanship Practice</p>	<p style="text-align: center;">UNACCEPTABLE SPLICE LOCATED IN FLEXURE ZONE</p> <p>The termination shall not be located in a flexure zone. Best Workmanship Practice</p>

NASA WORKMANSHIP STANDARDS

 <p>NATIONAL AERONAUTICS AND SPACE ADMINISTRATION JOHNSON SPACE CENTER HOUSTON, TEXAS USA 77058</p>	Released: 06.27.2002	Revision:	Revision Date:
	Book: 6	Section: 6.16	Page: 5



[Need a printed copy?](#)
(May take a while to load.)
Requires Adobe Reader.



[Need Adobe Reader?](#)
[Click here to download.](#)

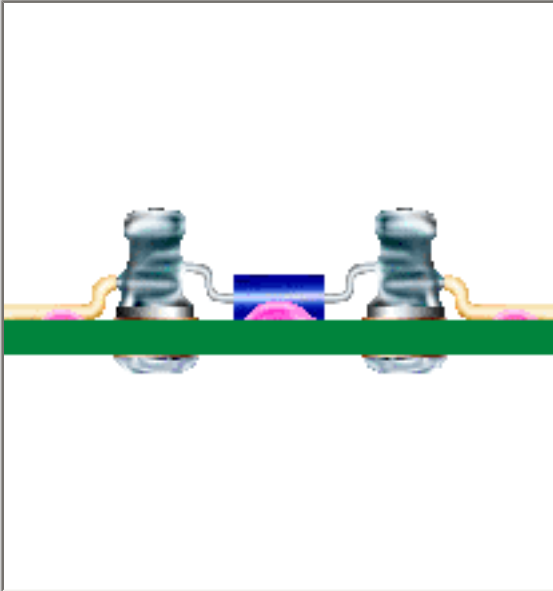
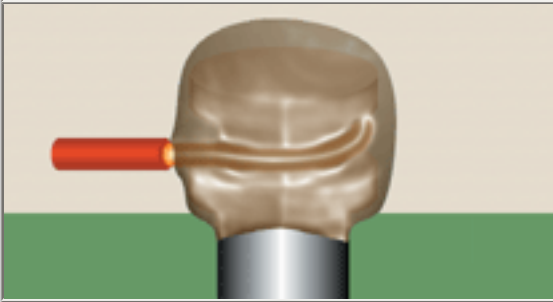
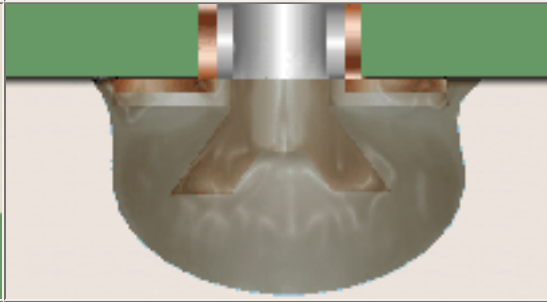
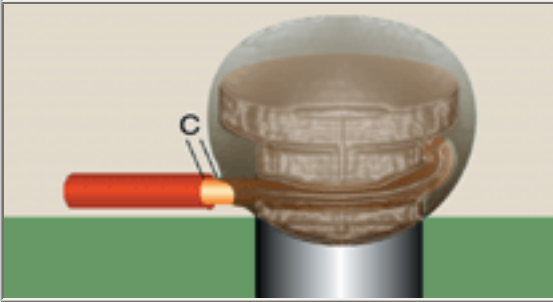
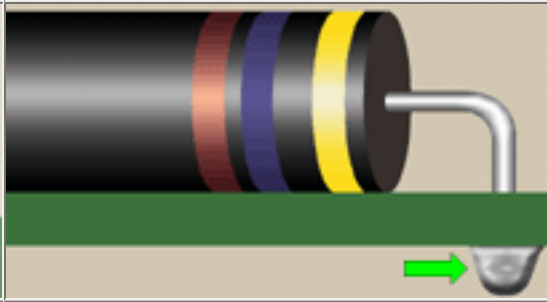

[Questions? Suggestions?](#)

THROUGH-HOLE SOLDERING HIGH VOLTAGE TERMINATIONS	
	<p>HIGH VOLTAGE TERMINATIONS</p> <p>High-voltage terminations, where coronal suppression is necessary, will require special design. All aspects of the soldered joints shall be covered by smooth fillets, free of discontinuities or severe change in surface contour (i.e. sharp edges, points, angles, etc.).</p> <p>See Section 6.01 "Through-Hole Soldering, General Requirements", for common accept/reject criteria.</p>
	
<p>PREFERRED</p> <p>The solder connection has a completely rounded, continuous and smooth profile. No evidence of sharp edges, points, icicles, inclusions (foreign material) or wire strands. Insulation clearance is as close to the solder connection as possible without embedment.</p> <p>NASA-STD-8739.3 [10.3]</p>	<p>PREFERRED FLARED FLANGE (TERMINAL)</p> <p>All edges of the terminal flange are completely covered with a continuous, smooth layer of solder to form a solder ball. The ball connection does not exceed specified height requirements.</p> <p>Best Workmanship Practice</p>
	
<p>PREFERRED INSULATION CLEARANCE</p> <p>The insulation gap is minimal, with the insulation as close to the solder connection as practical without embedment or damage.</p> <p>NASA-STD-8739.3 [9.1.1]</p>	<p>PREFERRED THROUGH HOLE TERMINATION</p> <p>All sharp edges of the component lead end are completely covered with a continuous, smooth, rounded layer of solder to form a solder ball. The ball connection does not exceed specified height requirements.</p> <p>Best Workmanship Practice</p>

NASA WORKMANSHIP STANDARDS



NATIONAL AERONAUTICS AND SPACE ADMINISTRATION
JOHNSON SPACE CENTER
HOUSTON, TEXAS USA 77058

Released:
06.27.2002

Revision:

Revision Date:

	Book: 6	Section: 6.17	Page: 1
--	------------	------------------	------------

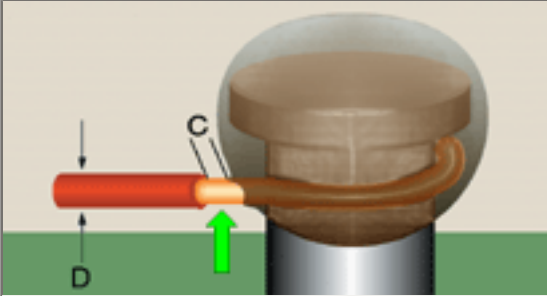
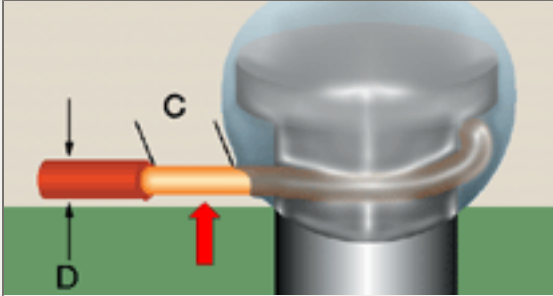
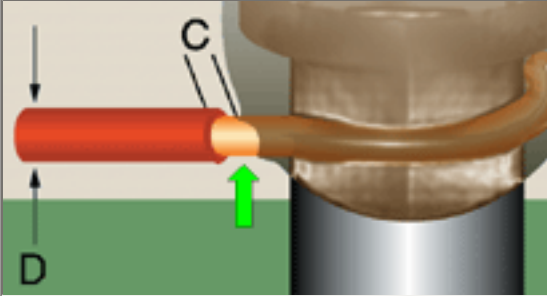
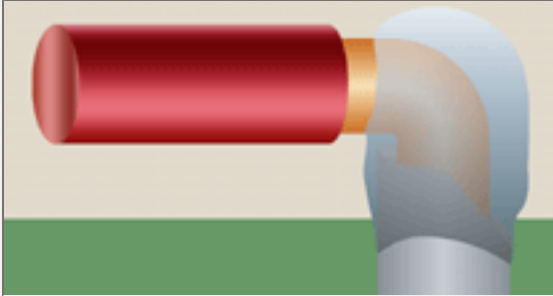
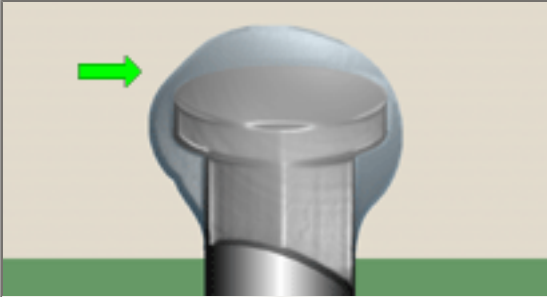
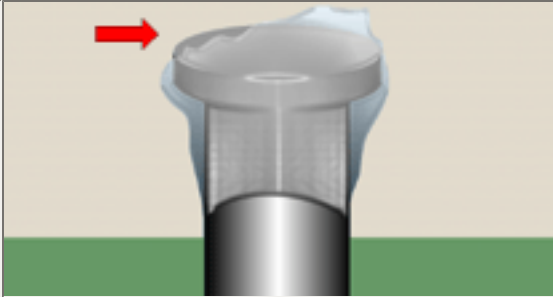
THROUGH-HOLE SOLDERING HIGH VOLTAGE TERMINATIONS (cont.)	
	
<p>ACCEPTABLE INSULATION CLEARANCE (C) (MAXIMUM)</p> <p>The insulation gap (C) is less than two insulated wire diameters (D). NASA-STD-8739.3 [9.1.2]</p>	<p>UNACCEPTABLE IMPROPER INSULATION CLEARANCE (C)</p> <p>The insulation gap (C) is greater than two insulated wire diameters, which may result in coronal formation and short circuits. NASA-STD-8739.3 [9.1.2], [13.6.2.a.2]</p>
	
<p>ACCEPTABLE INSULATION CLEARANCE (C) (MINIMUM)</p> <p>The insulation gap (C) is less than one insulated wire diameter (D), but is not embedded in the solder joint. NASA-STD-8739.3 [9.1.1]</p>	<p>ACCEPTABLE SOLDER CUP TERMINATIONS</p> <p>The connection has an egg-shaped, spherical, or oval profile following the contour of the terminal and wire wrap. No evidence of sharp edges, points, icicles, inclusions (foreign material), or wire strands. Insulation clearance is acceptable. NASA-STD-8739.3 [10.3]</p>
	

<p>ACCEPTABLE UNUSED TERMINAL</p> <p>All sharp edges of the terminal are completely covered with a smooth, continuous ball of solder.</p> <p>Best Workmanship Practice</p>	<p>UNACCEPTABLE UNUSED TERMINAL NO SOLDER/PARTIAL SOLDER</p> <p>All sharp edges of the terminal shall be completely covered with a smooth, continuous ball of solder.</p> <p>Best Workmanship Practice</p>
---	---

NASA WORKMANSHIP STANDARDS			
 <p>NATIONAL AERONAUTICS AND SPACE ADMINISTRATION JOHNSON SPACE CENTER HOUSTON, TEXAS USA 77058</p>	Released: 06.27.2002	Revision:	Revision Date:
	Book: 6	Section: 6.17	Page: 2

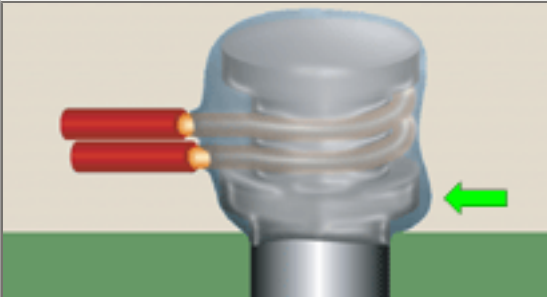
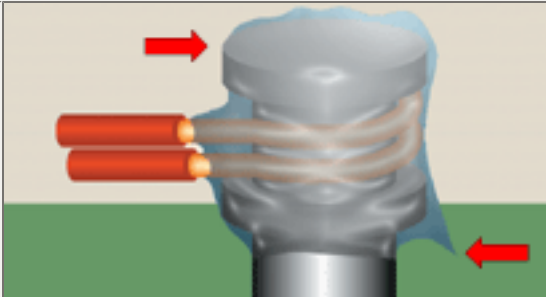
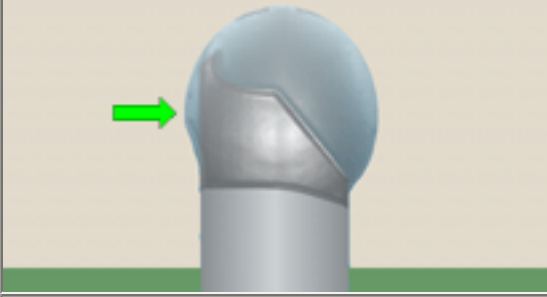
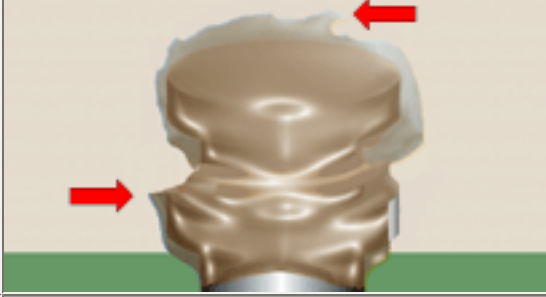
THROUGH-HOLE SOLDERING HIGH VOLTAGE TERMINATIONS (cont.)	
	
<p>ACCEPTABLE TERMINALS/WIRE LEAD</p> <p>The connection has an egg-shaped, spherical or oval profile that follows the contour of the terminal and wire wrap. No evidence of sharp edges, points, icicles, inclusions (foreign material), or wire strands. Insulation clearance is acceptable.</p> <p>NASA-STD-8739.3 [10.3]</p>	<p>UNACCEPTABLE SHARP EDGES</p> <p>The solder follows the contour of the terminal and wrap, BUT there is evidence of the sharp edge of the terminal protruding through the solder surface.</p> <p>NASA-STD-8739.3 [10.3]</p>
	
<p>ACCEPTABLE UNUSED SOLDER CUPS</p> <p>The solder connection has an egg-shaped, spherical or oval profile. No evidence of sharp edges, points, icicles, inclusions (foreign material) or wire strands.</p> <p>Best Workmanship Practice</p>	<p>UNACCEPTABLE UNUSED TERMINAL, SHARP EDGES</p> <p>The solder is continuous, BUT there is evidence of solder peaks, icicles or sharp turret edges protruding.</p> <p>Best Workmanship Practice</p>

NASA WORKMANSHIP STANDARDS			
 NATIONAL AERONAUTICS AND SPACE ADMINISTRATION JOHNSON SPACE CENTER HOUSTON, TEXAS USA 77058	Released: 06.27.2002	Revision:	Revision Date:
	Book: 6	Section: 6.17	Page: 3



[Need a printed copy?](#)
(May take a while to load.)
Requires Adobe Reader.



[Need Adobe Reader?](#)
[Click here to download.](#)



[Questions? Suggestions?](#)

**SURFACE MOUNT TECHNOLOGY (SMT)
GENERAL REQUIREMENTS**

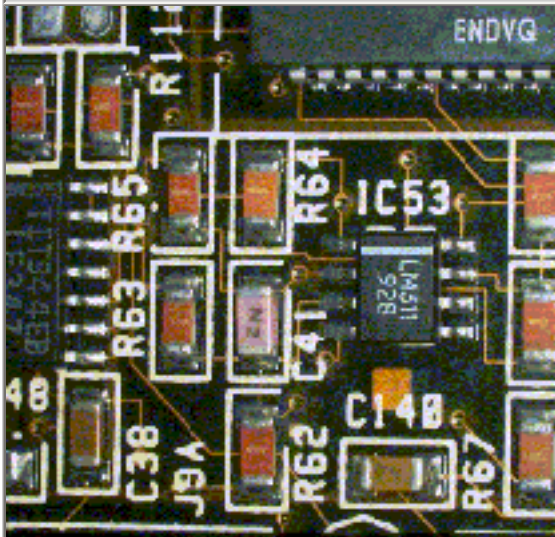

SURFACE MOUNT TECHNOLOGY
(SMT)
GENERAL REQUIREMENTS

Surface Mount Technology (SMT) is used to mount electronic components on the metallized surface of printed wiring boards (PWB) or substrates. SMT makes it possible to mount components on one or both sides of the printed wiring assembly (PWA), producing more reliable electronic assemblies at greatly reduced weight, volume and cost.

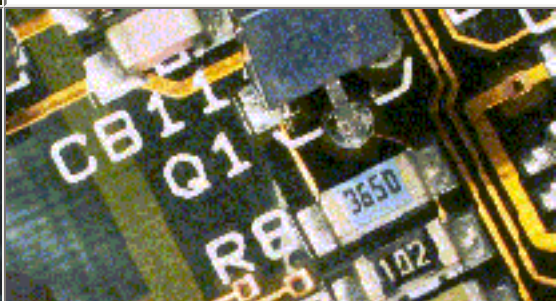
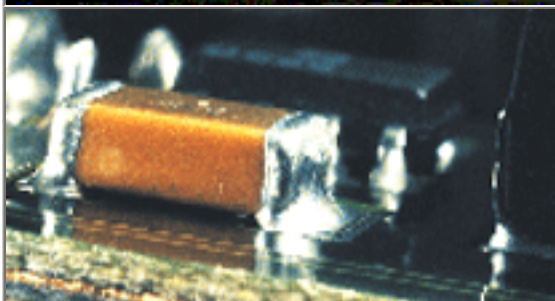

PREFERRED

The solder joint surface is smooth, nonporous, undisturbed with a finish varying from satin to bright. The fillet completely wets all elements to the periphery of the connection and is concave.

[NASA-STD-8739.2 \[12.8.1\]](#)

PREFERRED

Part markings are visible and oriented uniformly.

[NASA-STD-8739.2 \[8.7.4.a\]](#), [\[12.7.1.b\]](#), [\[12.8.1.f\]](#)

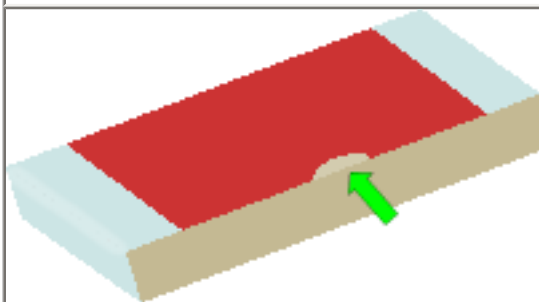

**ACCEPTABLE
CHIP-OUTS (NICKS)**

Chip-outs (nicks) of the top surface (adhesive coating), less than 0.25 mm from the component edge are acceptable. Chips in the component body, element area or termination area are unacceptable.

[NASA-STD-8739.2 \[8.7.4.b\]](#), [\[8.8.2\]](#)

**UNACCEPTABLE
CHIP-OUTS (NICKS)**

The use of chip-scale parts with chips in the component body or termination area, and any resistive elements with chip outs, is prohibited.

[NASA-STD-8739.2 \[12.8.2.a.3\]](#)

NASA WORKMANSHIP STANDARDS

 <p>NATIONAL AERONAUTICS AND SPACE ADMINISTRATION JOHNSON SPACE CENTER HOUSTON, TEXAS USA 77058</p>	Released: 06.27.2002	Revision:	Revision Date:
	Book: 7	Section: 7.01	Page: 1

SURFACE MOUNT TECHNOLOGY (SMT) GENERAL REQUIREMENTS (cont.)		
<p style="text-align: center;">ACCEPTABLE EXPOSED BASE METAL</p> <p>Exposed base metal on the vertical edges of circuit traces, lands and pads is acceptable. NASA-STD-8739.2 [12.8.2.c.5]</p>	<p style="text-align: center;">UNACCEPTABLE EXPOSED BASE METAL</p> <p>Exposed base metal is prohibited, except for the vertical edges of circuit traces, lands and pads. NASA-STD-8739.2 [12.8.2.c.5]</p>	
<p style="text-align: center;">ACCEPTABLE MEASLING</p> <p>Whitish, discrete spots or crosses below the laminate surface-usually induced by thermal shock/stress. Measling that bridges uncommon conductors is unacceptable. NASA-STD-8739.2 [12.8.2.c.3]</p>	<p style="text-align: center;">UNACCEPTABLE MEASLING</p> <p>Measling that bridges uncommon conductors is unacceptable. NASA-STD-8739.2 [12.8.2.c.3]</p>	
<p style="text-align: center;">ACCEPTABLE NONUNIFORM/UNEVEN FLOW/REFLOW</p> <p>A solder fillet exhibiting a nonuniform/uneven flow line is acceptable, provided there is evidence of good wetting. NASA-STD-8739.2 [12.8.1.g]</p>	<p style="text-align: center;">UNACCEPTABLE NONUNIFORM/UNEVEN FLOW/REFLOW</p> <p>The uneven flow/reflow of solder is typically caused by an inadequate/uneven application of heat. The condition is acceptable if good wetting is evident. NASA-STD-8739.2 [12.8.1.g], [12.8.2.b.4]</p>	
NASA WORKMANSHIP STANDARDS		
	Released: 06.27.2002	Revision: Revision Date:



NATIONAL AERONAUTICS AND SPACE ADMINISTRATION
 JOHNSON SPACE CENTER
 HOUSTON, TEXAS USA 77058

Book:
7

Section:
7.01

Page:
2

SURFACE MOUNT TECHNOLOGY (SMT)
 GENERAL REQUIREMENTS (cont.)

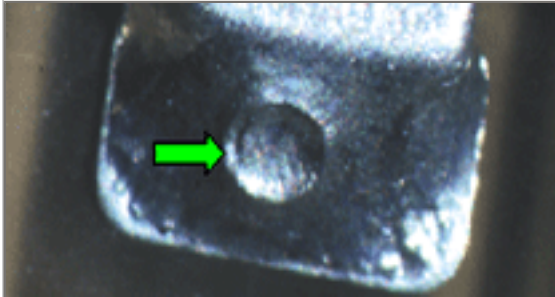

ACCEPTABLE
PITS

A solder pit is acceptable, provided the bottom of the cavity can be seen from all angles of vision.

[NASA-STD-8739.2 \[3.1\], \[12.8.2.b.5\]](#)

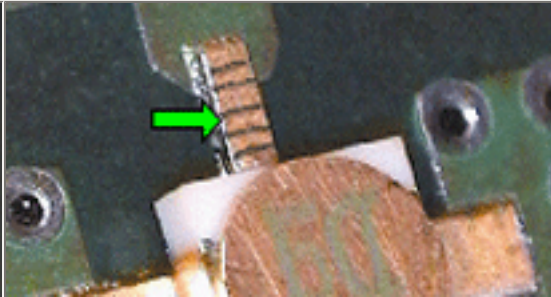

ACCEPTABLE
SMOOTH TOOL IMPRESSION MARKS

Smooth tool impression marks (slight cuts, nicks, scratches or scrapes) on the conductor surface, which do not expose base metal or reduce cross-sectional area are acceptable.

[NASA-STD-8739.2 \[12.8.2.a.4\]](#)

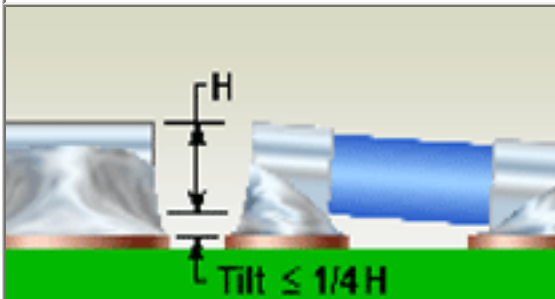

ACCEPTABLE
TILT

Part tilt shall not exceed 25% of component height (H) or diameter (i.e. MELFs), and shall not interfere with the proper placement of adjacent parts.

[Best Workmanship Practice](#)

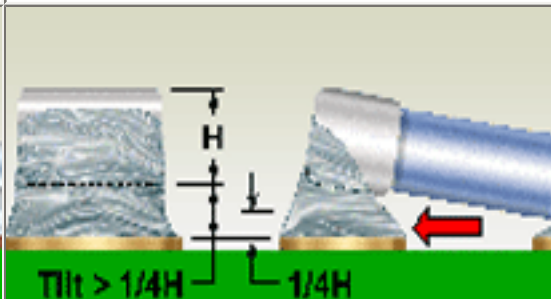

UNACCEPTABLE
EXCESS TILT

Excessive tilting of a component may impact the long-term reliability and integrity of the solder termination, and may interfere with the proper placement and thermal profile of adjacent parts.

[Best Workmanship Practice](#)

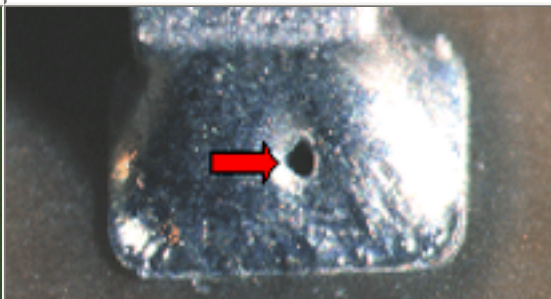
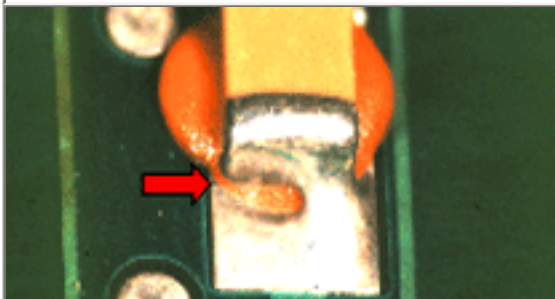

<p>UNACCEPTABLE ADHESIVE INCLUSION</p> <p>Adhesive material in the solder joint shall be cause for rejection.</p> <p>NASA-STD-8739.2 [8.10.3], [12.8.2.b.9]</p>	<p>UNACCEPTABLE BLOWHOLE</p> <p>Blowholes are typically caused by trapped gases or flux during the formation of the solder fillet, and are unacceptable.</p> <p>NASA-STD-8739.2 [12.8.2.b.5]</p>
--	---

NASA WORKMANSHIP STANDARDS

 <p>NATIONAL AERONAUTICS AND SPACE ADMINISTRATION JOHNSON SPACE CENTER HOUSTON, TEXAS USA 77058</p>	Released: 06.27.2002	Revision:	Revision Date:
	Book: 7	Section: 7.01	Page: 3

**SURFACE MOUNT TECHNOLOGY (SMT)
GENERAL REQUIREMENTS (cont.)**

	
<p>UNACCEPTABLE BRIDGING</p> <p>Bridging is an indicator of poor process controls (i.e. excess solder, smeared paste, improper placement, incorrect heat).</p> <p>NASA-STD-8739.2 [12.8.2.c.4]</p>	<p>UNACCEPTABLE CHARRING</p> <p>Charring of components and/or laminate is an indicator of poor process control (i.e. excessive heat).</p> <p>NASA-STD-8739.2 [12.8.2.a.3]</p>
	
<p>UNACCEPTABLE COLD SOLDER JOINT</p> <p>A cold solder joint is an indicator of incorrect process control (i.e. inadequate heat).</p> <p>NASA-STD-8739.2 [12.8.2.b.1]</p>	<p>UNACCEPTABLE CONTAMINATION</p> <p>Contamination is a reliability concern. Residual flux and other contaminants can lead to corrosion and circuit failure.</p> <p>NASA-STD-8739.2 [12.8.2.b.9]</p>



**UNACCEPTABLE
COPLANARITY**

Improper coplanarity of leaded parts will result in bridging, shorts and misalignment. Parts shall be reworked prior to installation.

[NASA-STD-8739.2 \[7.1\]](#)

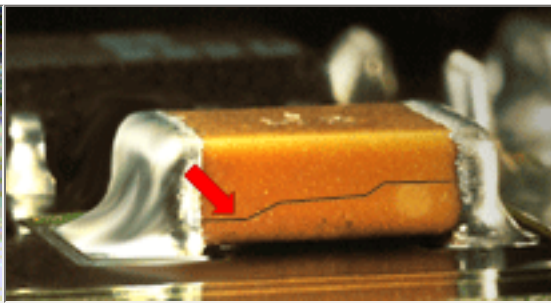

**UNACCEPTABLE
CRACKS (COMPONENT)**

Cracks (especially in ceramic components) are an indicator of poor process control (i.e. improper preheat, thermal/mechanical shock, etc.).

[NASA-STD-8739.2 \[12.8.2.a.3\]](#)

NASA WORKMANSHIP STANDARDS



**NATIONAL AERONAUTICS AND
SPACE ADMINISTRATION**
JOHNSON SPACE CENTER
HOUSTON, TEXAS USA 77058

Released:
06.27.2002

Revision:

Revision Date:

Book:
7

Section:
7.01

Page:
4

**SURFACE MOUNT TECHNOLOGY (SMT)
GENERAL REQUIREMENTS (cont.)**

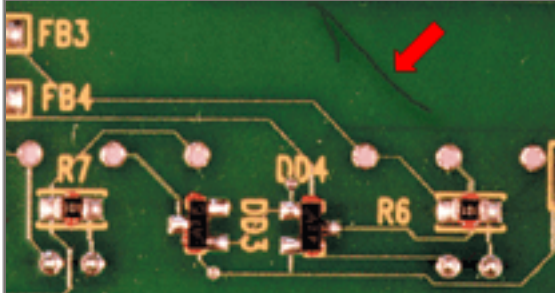

**UNACCEPTABLE
CRACKS (LAMINATE)**

Cracks in the laminate are a reliability concern and are a cause for rejection.

[Best Workmanship Practice](#)

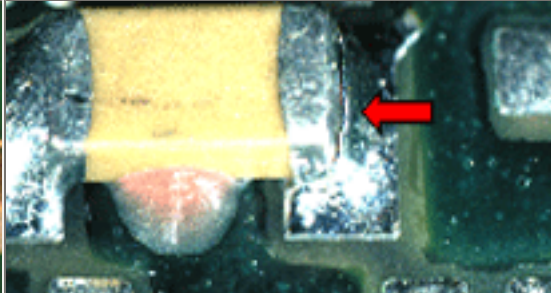

**UNACCEPTABLE
CRACKS (SOLDER FILLET)**

Cracks or fractures in the solder fillet are an indication of mechanical / thermal shock or temperature coefficient mismatch.

[NASA-STD-8739.2 \[12.8.2.b.3\]](#)

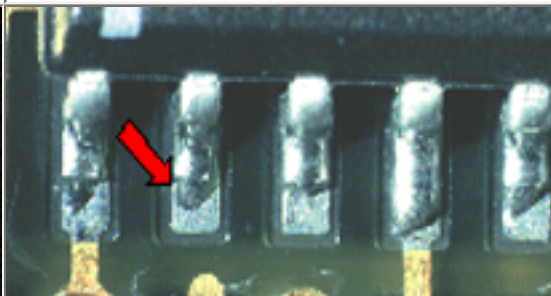

<p style="text-align: center;">UNACCEPTABLE DAMAGED PART SEAL</p> <p>Parts with damaged seals shall not be used. NASA-STD-8739.2 [12.7.2.b]</p>	<p style="text-align: center;">UNACCEPTABLE DEWETTING</p> <p>Dewetting is an indicator of poor process control (i.e. excessive heat dwell following reflow). NASA-STD-8739.2 [12.8.2.b.10]</p>
	
<p style="text-align: center;">UNACCEPTABLE DISCOLORED LAMINATE (BURNS)</p> <p>Burns that physically damage the laminate surface of the assembly are not allowed. Slight discoloration is allowable. NASA-STD-8739.2 [12.8.2.c.2]</p>	<p style="text-align: center;">UNACCEPTABLE DISTURBED SOLDER</p> <p>A disturbed solder joint is an indicator of improper process control. NASA-STD-8739.2 [12.8.2.b.3]</p>

NASA WORKMANSHIP STANDARDS			
 <p>NATIONAL AERONAUTICS AND SPACE ADMINISTRATION JOHNSON SPACE CENTER HOUSTON, TEXAS USA 77058</p>	Released: 06.27.2002	Revision:	Revision Date:
	Book: 7	Section: 7.01	Page: 5

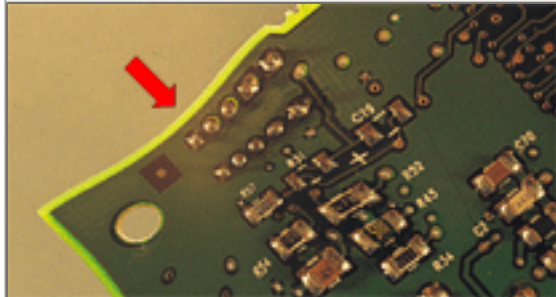
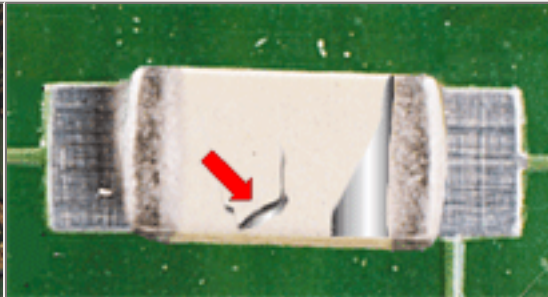
SURFACE MOUNT TECHNOLOGY (SMT) GENERAL REQUIREMENTS (cont.)	
	
<p style="text-align: center;">UNACCEPTABLE EXCESSIVE BOW/TWIST (PWB)</p> <p>Excessive bow or twist may inhibit proper mounting and may result in mechanical interference or shorting to adjacent assemblies or chassis. Best Workmanship Practice</p>	<p style="text-align: center;">UNACCEPTABLE EXPOSED DIE/CIRCUIT ELEMENTS</p> <p>The unprotected exposure of die or circuit elements is not allowed unless specified in the engineering documentation. NASA-STD-8739.2 [8.8.2]</p>

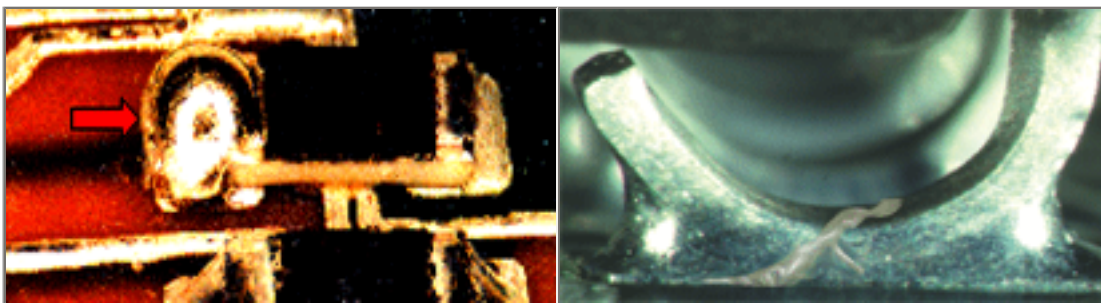

**UNACCEPTABLE
EXCESS SOLDER**

The solder fillet shall exhibit a positive wetting angle and shall not contact the component body.

[NASA-STD-8739.2 \[12.8.2.b.12\]](#)

**UNACCEPTABLE
FLUX RESIDUE**

Flux residue indicates improper / incomplete cleaning.

[NASA-STD-8739.2 \[12.8.2.a.5\]](#)

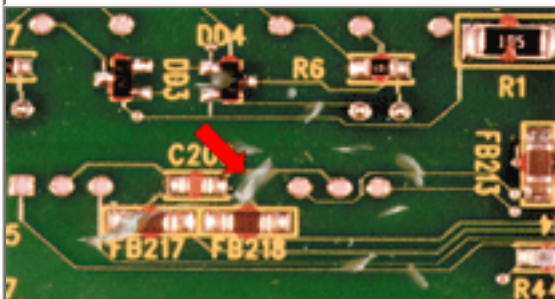

**UNACCEPTABLE
FLUX SPLATTER**

Flux splatter is an indication of an improper process parameter (heat / moisture).

[NASA-STD-8739.2 \[12.8.2.b.7\]](#)

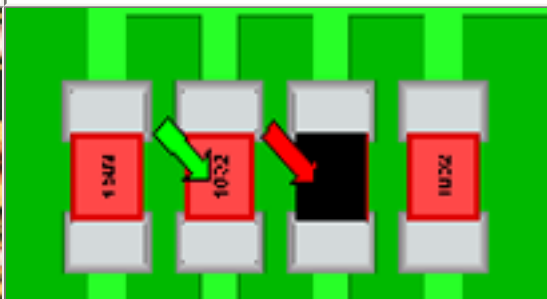

**UNACCEPTABLE
GLASS SIDE DOWN**

Thick film components shall be mounted with the protective glass film side in the up position.

[NASA-STD-8739.2 \[8.8.3\], \[12.7.1\]](#)

NASA WORKMANSHIP STANDARDS



**NATIONAL AERONAUTICS AND
SPACE ADMINISTRATION**
JOHNSON SPACE CENTER
HOUSTON, TEXAS USA 77058

Released:
06.27.2002

Revision:

Revision Date:

Book:
7

Section:
7.01

Page:
6

**SURFACE MOUNT TECHNOLOGY (SMT)
GENERAL REQUIREMENTS (cont.)**

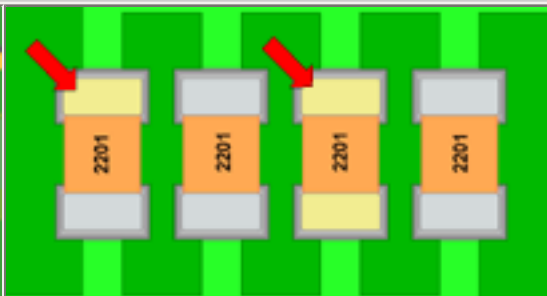
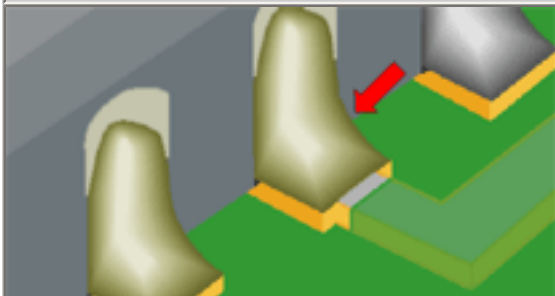

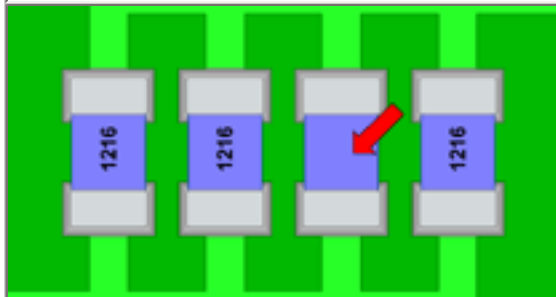
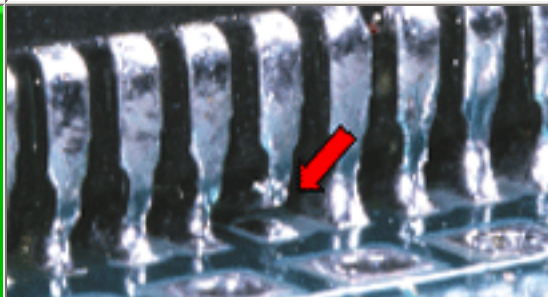
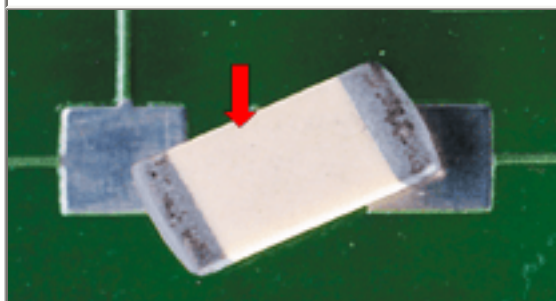
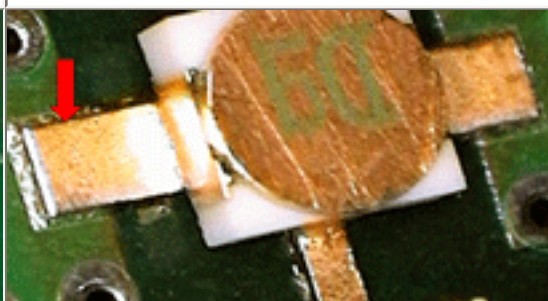
<p style="text-align: center;">UNACCEPTABLE GOLD INTERMETALLIC</p> <p>Gold intermetallic can severely embrittle a solder joint. NASA-STD-8739.2 [12.8.2.b.22]</p>	<p style="text-align: center;">UNACCEPTABLE GOLD PLATING</p> <p>Gold plating surfaces that will become a part of the finished solder connection shall be tinned prior to soldering to remove the gold plating. NASA-STD-8739.2 [7.2.1.b]</p>
	
<p style="text-align: center;">UNACCEPTABLE IDENTIFICATION MARKS MISSING</p> <p>Parts shall be mounted with the identification markings visible. NASA-STD-8739.2 [8.7.4.a], [12.6.3.1]</p>	<p style="text-align: center;">UNACCEPTABLE IMPROPER LEAD SPACING</p> <p>Leads shall not exhibit spacing separation in excess of 0.26 mm (0.010 in.) above the solder land. NASA-STD-8739.2 [12.8.2.a.10]</p>
	
<p style="text-align: center;">UNACCEPTABLE IMPROPER ORIENTATION</p> <p>Parts shall be mounted parallel to the laminate surface, right side up, and aligned to the lands within design and engineering specifications. NASA-STD-8739.2 [8.7.4], [12.7.1.b]</p>	<p style="text-align: center;">UNACCEPTABLE IMPROPER TINNING</p> <p>Tinned surfaces shall exhibit at least 95% coverage. NASA-STD-8739.2 [7.2], [12.8.2.a.1]</p>

NASA WORKMANSHIP STANDARDS

 <p>NATIONAL AERONAUTICS AND SPACE ADMINISTRATION JOHNSON SPACE CENTER HOUSTON, TEXAS USA 77058</p>	Released: 06.27.2002	Revision:	Revision Date:
	Book: 7	Section: 7.01	Page: 7

SURFACE MOUNT TECHNOLOGY (SMT)
GENERAL REQUIREMENTS (cont.)

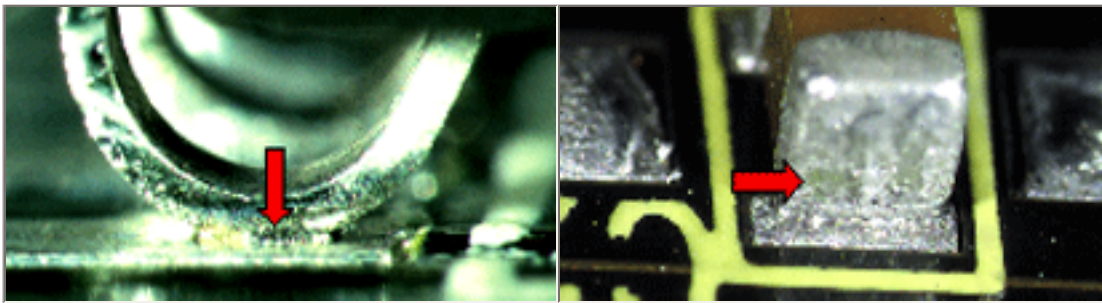

**UNACCEPTABLE
INSUFFICIENT SOLDER**

Insufficient solder is an indicator of improper process control, and may result in reduced reliability. In this example, there is no side or heel fillet.

[NASA-STD-8739.2 \[12.8.2.b.6\]](#)

**UNACCEPTABLE
LEACHING**

Parts exhibiting leaching or loss of metallization in the termination area shall be rejected.

[NASA-STD-8739.2 \[12.9.1.b.6\]](#)

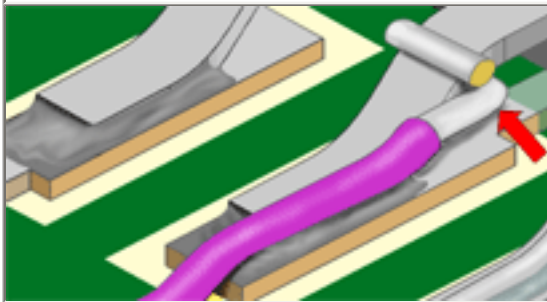

**UNACCEPTABLE
LEADS USED AS TERMINALS**

Part leads shall not be used as terminals, except when the part lead is used as a terminal.

[NASA-STD-8739.2 \[12.8.2.a.9\]](#)

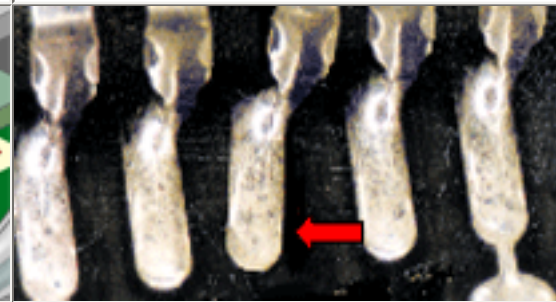

**UNACCEPTABLE
LIFTED PAD/TRACE**

Termination pads or traces exhibiting separation from the substrate shall be cause for rejection.

[NASA-STD-8739.2 \[12.8.2.c.1\]](#), [\[12.8.2.c.9\]](#)

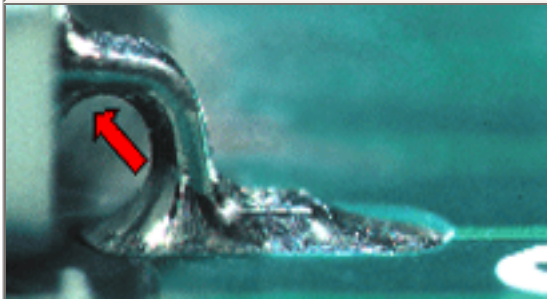

**UNACCEPTABLE
MENISCUS CONTACT**

Parts exhibiting contact with, or embedment of, the meniscus and the solder joint, shall be rejected.

[NASA-STD-8739.2 \[12.8.2.b.12\]](#)

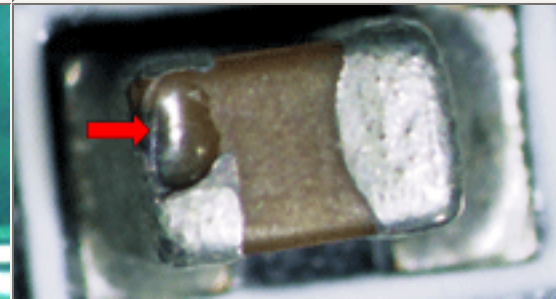

**UNACCEPTABLE
NICKS**

The use of parts with nicks in the component body or termination area is prohibited.

[NASA-STD-8739.2 \[12.6.3.2\]](#), [\[12.8.2.a.3\]](#)

NASA WORKMANSHIP STANDARDS



**NATIONAL AERONAUTICS AND
SPACE ADMINISTRATION**
**JOHNSON SPACE CENTER
HOUSTON, TEXAS USA 77058**

Released:
06.27.2002

Revision:

Revision Date:

Book:
7

Section:
7.01

Page:
8

SURFACE MOUNT TECHNOLOGY (SMT) GENERAL REQUIREMENTS (cont.)		
		
<p style="text-align: center;">UNACCEPTABLE NO FLOW/REFLOW</p> <p>The lack of proper flow/reflow of solder paste/preforms is an indicator of poor process control or layout design (i.e. inadequate heat, shadowing). NASA-STD-8739.2 [12.8.1]</p>	<p style="text-align: center;">UNACCEPTABLE NO SOLDER</p> <p>The lack of solder is an indicator of poor process control. NASA-STD-8739.2 [12.6.1.a.4], [12.8.2.b.6]</p>	
		
<p style="text-align: center;">UNACCEPTABLE NONWETTING</p> <p>Nonwetting is an indicator of poor solderability or contamination. NASA-STD-8739.2 [12.8.2.b.11]</p>	<p style="text-align: center;">UNACCEPTABLE OPENS/VOIDS</p> <p>Opens/Voids are an indicator of insufficient solder, solder wicking and/or coplanarity problems. NASA-STD-8739.2 [12.8.2.b.5], [12.8.2.b.6]</p>	
		
<p style="text-align: center;">UNACCEPTABLE OVERHEATED SOLDER</p> <p>Overheated solder has a dull, gray, frosty and/or crystallized appearance and is the result of excessive exposure to heat. NASA-STD-8739.2 [12.8.2.b.2]</p>	<p style="text-align: center;">UNACCEPTABLE PARTS MISALIGNMENT</p> <p>Part misalignment is an indicator of improper process control. NASA-STD-8739.2 [8.7.4], [12.8.2.a.2]</p>	
NASA WORKMANSHIP STANDARDS		
	Released: 06.27.2002	Revision Date:



SURFACE MOUNT TECHNOLOGY (SMT)
GENERAL REQUIREMENTS (cont.)

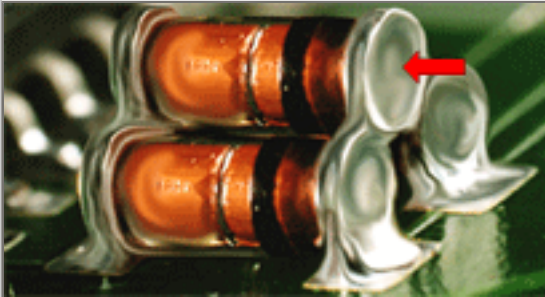

UNACCEPTABLE
PIGGYBACKED PARTS

Piggybacking, or stacking, of parts not designed specifically for that configuration is prohibited.

[NASA-STD-8739.2 \[8.7.4.e\]](#), [\[12.6.2.a.1\]](#)

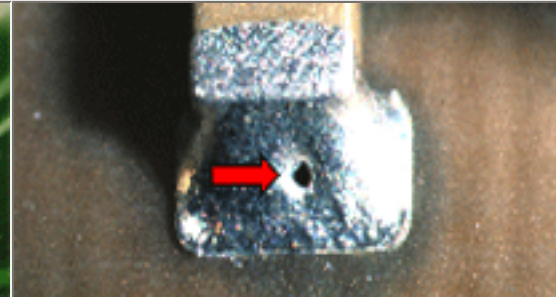

UNACCEPTABLE
PINHOLE

Pinholes are typically small holes in the solder surface, leading to a void of indeterminate size within the solder termination.

[NASA-STD-8739.2 \[12.8.2.b.5\]](#)



UNACCEPTABLE
POOR WETTING

Poor wetting is an indicator of poor solderability, improper flux or contamination.

[NASA-STD-8739.2 \[12.8.2.b.4\]](#)

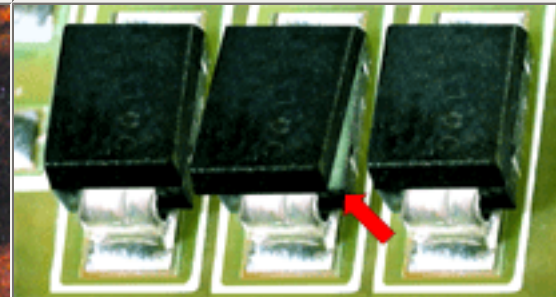

UNACCEPTABLE
POPCORNING

Popcorning is caused by the release of pressure entrapped in the component body during the soldering process. The effect can be relatively minor (body distortion), or destructive (seal breach or delidding).

[NASA-STD-8739.2 \[12.7.2.b\]](#), [\[12.8.2.a.3\]](#)

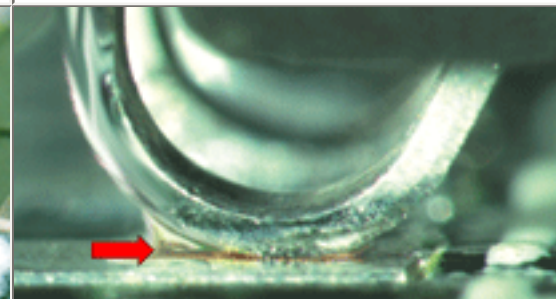
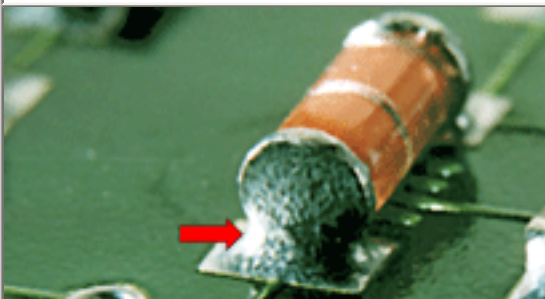

<p>UNACCEPTABLE POROUS SOLDER</p> <p>Porous solder is an indication of improper process control (i.e. excessive flux, inadequate dwell time).</p> <p>NASA-STD-8739.2 [12.8.2.b.17]</p>	<p>UNACCEPTABLE ROSIN SOLDER JOINT</p> <p>A rosin solder joint is an indication of improper process control (i.e. excessive flux, inadequate dwell time).</p> <p>NASA-STD-8739.2 [12.8.2.b.8]</p>
---	--

NASA WORKMANSHIP STANDARDS

 <p>NATIONAL AERONAUTICS AND SPACE ADMINISTRATION JOHNSON SPACE CENTER HOUSTON, TEXAS USA 77058</p>	Released: 06.27.2002	Revision:	Revision Date:
	Book: 7	Section: 7.01	Page: 10

**SURFACE MOUNT TECHNOLOGY (SMT)
GENERAL REQUIREMENTS (cont.)**

	
<p>UNACCEPTABLE SCRATCHES (SOLDER FILLET)</p> <p>Scratches in the solder are prohibited.</p> <p>NASA-STD-8739.2 [12.8.2.b.14]</p>	<p>UNACCEPTABLE SOLDER BALLS/SOLDER FINES</p> <p>Solder balls or fines are an indication of improper process control (inadequate preheat), and/or the use of outdated solder/flux.</p> <p>NASA-STD-8739.2 [12.8.2.b.19]</p>
	
<p>UNACCEPTABLE SOLDER IN STRESS RELIEF BEND</p> <p>Solder shall not extend into the stress relief bend or any leaded part. In this example, the solder is also in contact with the part body and the body seal.</p> <p>NASA-STD-8739.2 [12.8.2.b.16]</p>	<p>UNACCEPTABLE SOLDER PEAKS, ICICLES, SHARP EDGES</p> <p>Solder peaks, icicles and/or sharp edges are an indicator of an improper process parameter and are a reliability and short-circuit concern.</p> <p>NASA-STD-8739.2 [12.8.2.c.4]</p>

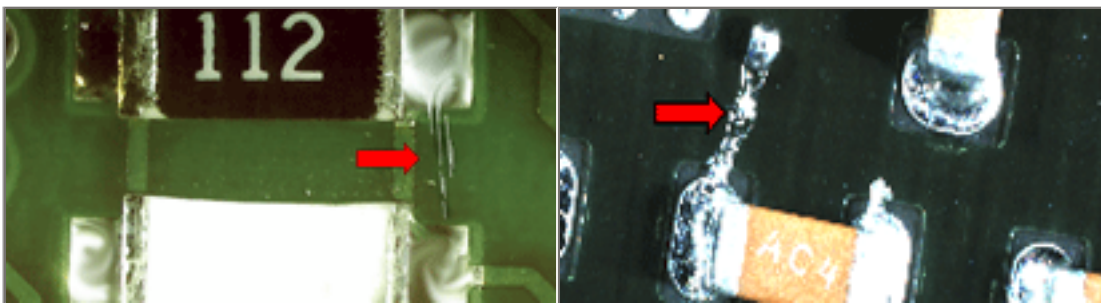

**UNACCEPTABLE
SOLDER SLIVERS**

Solder slivers are an indication of improper process control, and are a reliability and short-circuit concern.

[NASA-STD-8739.2 \[12.8.2.b.20\]](#)

**UNACCEPTABLE
SOLDER WEBBING**

Webbing is an indication of improper process control, and is a reliability and short-circuit concern.

[NASA-STD-8739.2 \[12.8.2.b.18\]](#)

NASA WORKMANSHIP STANDARDS



**NATIONAL AERONAUTICS AND
SPACE ADMINISTRATION**
JOHNSON SPACE CENTER
HOUSTON, TEXAS USA 77058

Released:
06.27.2002

Revision:

Revision Date:

Book:
7

Section:
7.01

Page:
11

**SURFACE MOUNT TECHNOLOGY (SMT)
GENERAL REQUIREMENTS (cont.)**

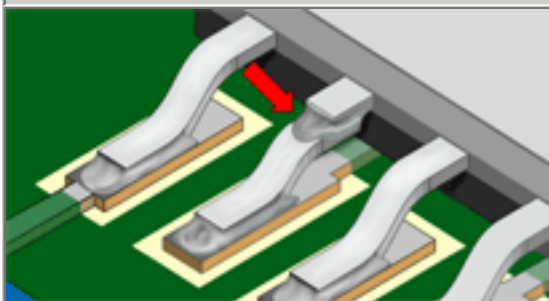

**UNACCEPTABLE
SPLICED LEADS**

Parts having spliced leads shall be rejected.

[NASA-STD-8739.2 \[12.8.2.a.8\]](#)



**UNACCEPTABLE
TOMBSTONING**

Tombstoning is an indicator of poor process control, primarily inadequate solder paste or inadequate/uneven application of heat.

[NASA-STD-8739.2 \[12.8.2.a.2\]](#), [\[12.9.1.b.1\]](#)



**UNACCEPTABLE
WHISKER**

A whisker is a slender needle-shaped metallic growth, and is typically the result of mechanical stresses in high tin-alloy plating on component leads. Whiskers are mechanically stronger than dendrites, and are a "dead-short" reliability risk.

[NASA-STD-8739.2 \[12.8.2.b.21\]](#)

NASA WORKMANSHIP STANDARDS			
 NATIONAL AERONAUTICS AND SPACE ADMINISTRATION JOHNSON SPACE CENTER HOUSTON, TEXAS USA 77058	Released: 06.27.2002	Revision:	Revision Date:
	Book: 7	Section: 7.01	Page: 12



[Need a printed copy?](#)
(May take a while to load.)
 Requires Adobe Reader.

[click here to download
Adobe Reader](#)

[Need Adobe Reader?](#)
[Click here to download.](#)



[Questions? Suggestions?](#)

**SURFACE MOUNT TECHNOLOGY (SMT)
SOLDER PASTE/SOLDER PREFORM APPLICATION**

SOLDER PASTE/PREFORM APPLICATION

Solder paste is a mixture of solder alloy particles, flux and other materials for use in reflow soldering (oven, vapor phase or infrared) of surface mount technology (SMT) components.

Solder preforms are generally made from solder alloy wire or stamped from solder alloy sheet material, and formed into specific shapes (typically toroids, washers or donuts) for use in reflow soldering (oven, vapor phase or infrared) of Plated Through Hole (PTH) components and some Surface Mount Technology (SMT) components.

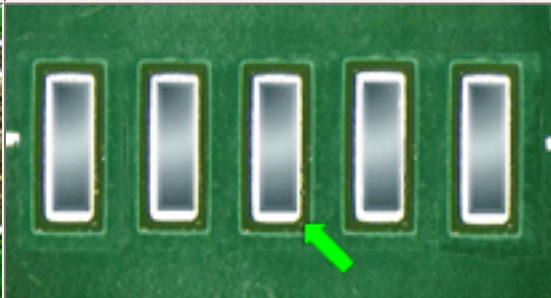
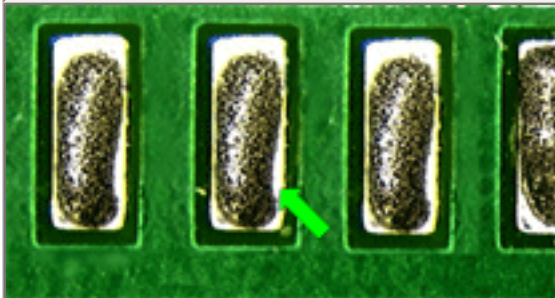
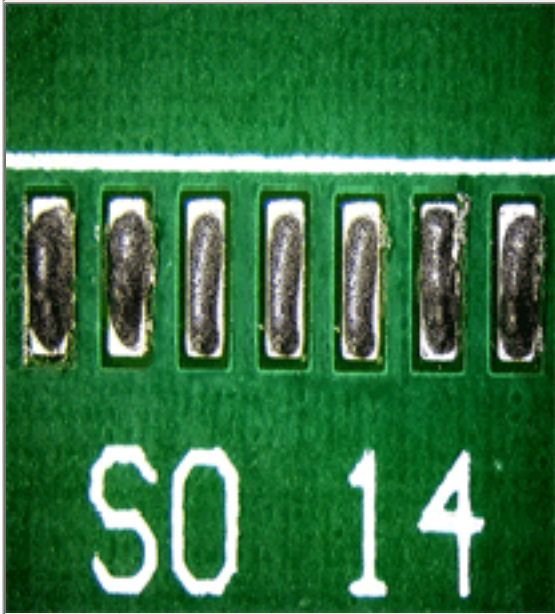

**ACCEPTABLE
SOLDER PASTE APPLICATION**

The paste is applied in a uniform thickness, with proper alignment and placement. There is no bridging, bubbles, crusting, separation or smearing.

[NASA-STD-8739.2 \[8.2\], \[8.6\]](#)

**ACCEPTABLE
SOLDER PREFORM APPLICATION**

The preforms are applied with proper alignment and placement.

[Best Workmanship Practice](#)



bubbles in the paste

**UNACCEPTABLE
BRIDGING**

Bridging of lands is an indicator of improper screen alignment/paste application.

[NASA-STD-8739.2 \[8.7.4.f\], \[12.6.1.a.1\]](#)

**UNACCEPTABLE
BUBBLES**

Bubbles in the paste are typically caused by over-mixing and can affect solder joint formation.

[NASA-STD-8739.2 \[12.6.1.a.3\]](#)

NASA WORKMANSHIP STANDARDS

Released:
06.27.2002

Revision:

Revision Date:



NATIONAL AERONAUTICS AND SPACE ADMINISTRATION
 JOHNSON SPACE CENTER
 HOUSTON, TEXAS USA 77058

Book:
7

Section:
7.02

Page:
1

SURFACE MOUNT TECHNOLOGY (SMT)
 SOLDER PASTE/SOLDER PREFORM APPLICATION (cont.)



UNACCEPTABLE
CRUSTING

Crusting of paste is an indicator of improper curing or use of expired material.

[NASA-STD-8739.2 \[6.12.2.d.6\]](#)

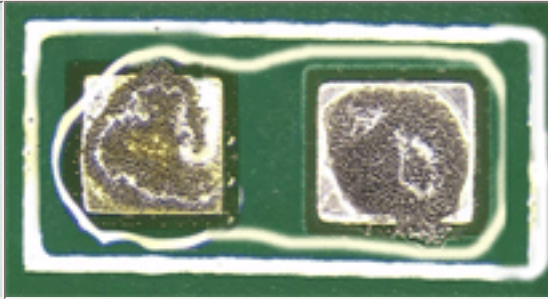

UNACCEPTABLE
EXCESS FLUX

Excess flux can degrade the formation of the solder fillet, leading to porous or rosin solder joints.

[Best Workmanship Practice](#)

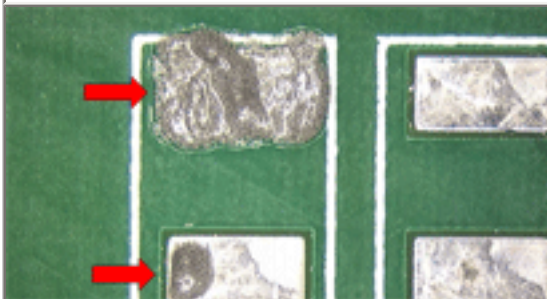

UNACCEPTABLE
INCORRECT COVERAGE

Solder paste coverage, which exhibits properties less than those specified by engineering documentation, shall be rejected.

[NASA-STD-8739.2 \[12.6.1.a.4\]](#)

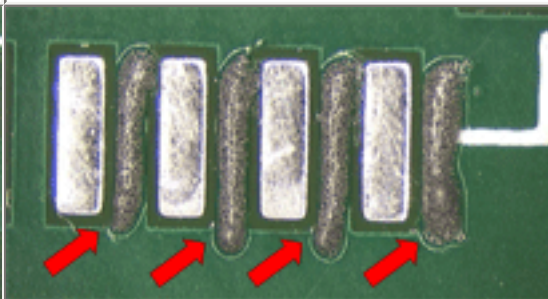

UNACCEPTABLE
INCORRECT PLACEMENT

Incorrect placement of solder paste/preforms is an indicator of an improper process parameter.

[NASA-STD-8739.2 \[12.6.1.a.5\]](#)

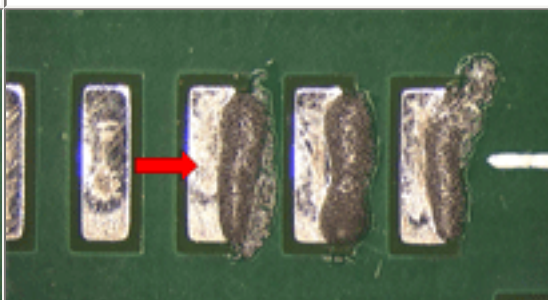
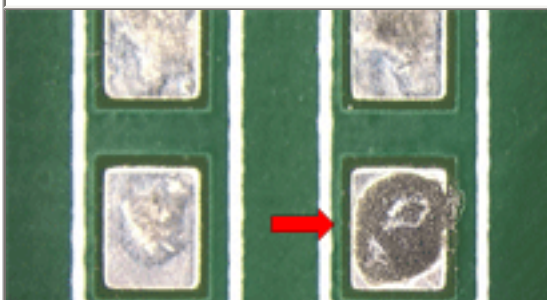

<p>UNACCEPTABLE ISOLATED DEPOSIT</p> <p>Isolated deposition of solder paste is an indicator of a process control problem. NASA-STD-8739.2 [12.6.1.a.2]</p>	<p>UNACCEPTABLE MISALIGNMENT</p> <p>Solder paste misalignment shall not be in excess of 25% of the spacing between lands. NASA-STD-8739.2 [12.6.1.a.5]</p>
---	---

NASA WORKMANSHIP STANDARDS			
 <p>NATIONAL AERONAUTICS AND SPACE ADMINISTRATION JOHNSON SPACE CENTER HOUSTON, TEXAS USA 77058</p>	Released: 06.27.2002	Revision:	Revision Date:
	Book: 7	Section: 7.02	Page: 2

SURFACE MOUNT TECHNOLOGY (SMT) SOLDER PASTE/SOLDER PREFORM APPLICATION (cont.)	
	
<p>UNACCEPTABLE MISSING DEPOSIT/PREFORM</p> <p>Missing paste deposits or preforms are an indicator of an improper process. NASA-STD-8739.2 [8.2]</p>	<p>UNACCEPTABLE PASTE SEPARATION</p> <p>Paste which exhibits separation shall be rejected. Best Workmanship Practice</p>
	
<p>UNACCEPTABLE SMEARING</p> <p>Smearing that bridges conductors or lands is an indicator of an improper process or handling and shall be rejected. NASA-STD-8739.2 [8.7.4.f], [12.6.1.a.6]</p>	

NASA WORKMANSHIP STANDARDS			
 NATIONAL AERONAUTICS AND SPACE ADMINISTRATION JOHNSON SPACE CENTER HOUSTON, TEXAS USA 77058	Released: 06.27.2002	Revision:	Revision Date:
	Book: 7	Section: 7.02	Page: 3



[Need a printed copy?](#)
(May take a while to load.)
Requires Adobe Reader.



[Need Adobe Reader?](#)
[Click here to download.](#)



[Questions? Suggestions?](#)

**SURFACE MOUNT TECHNOLOGY (SMT)
ADHESIVE APPLICATION**

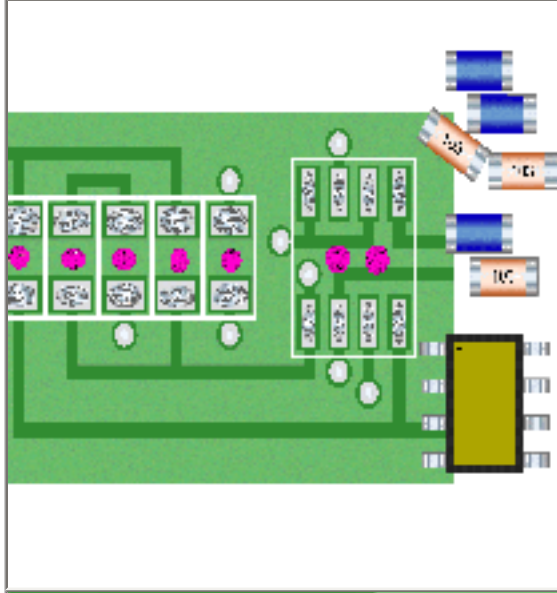

**SURFACE MOUNT TECHNOLOGY (SMT)
ADESIVE APPLICATION**

Adhesives are frequently used to temporarily hold SMT components in position prior to soldering. Once the soldering operations are completed, the adhesive residue is removed during the cleaning process.

The application of adhesive should be controlled to ensure proper placement, amount and cure. Excess adhesive, improper placement, or incomplete cure can contaminate solder paste and solderable surfaces, interfere with proper component alignment and impact cleanability.

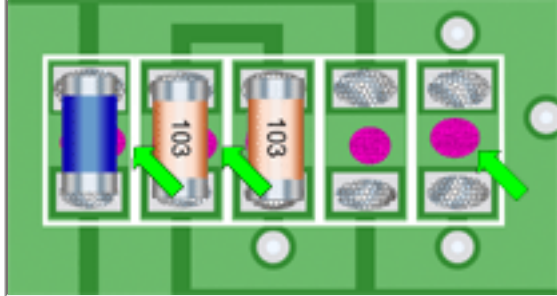

PREFERRED

The deposition of adhesive is consistent, properly placed and repeatable. Dots are centered under the part body, equal distant between the land pattern areas.

[NASA-STD-8739.2 \[8.9\]](#), [\[8.10.2\]](#)

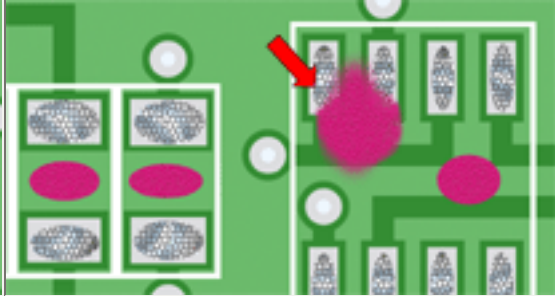

**UNACCEPTABLE
ADHESIVE ON LEADS/SOLDER PADS**

Adhesive deposits on part leads and/or solder pads interfere with proper placement, component retention and solderability.

[NASA-STD-8739.2 \[8.10.3\]](#)

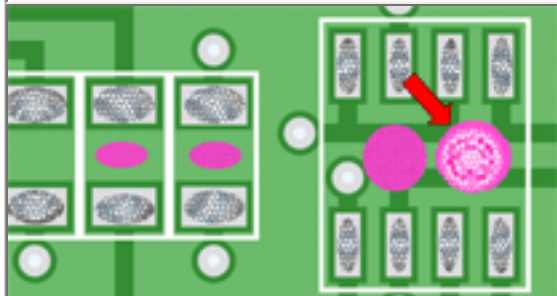

**UNACCEPTABLE
VOIDS**

Bubbles and voids in the adhesive reduce the deposit's cross-section and retention properties.

[NASA-STD-8739.2 \[8.9\]](#), [\[8.10.1\]](#)

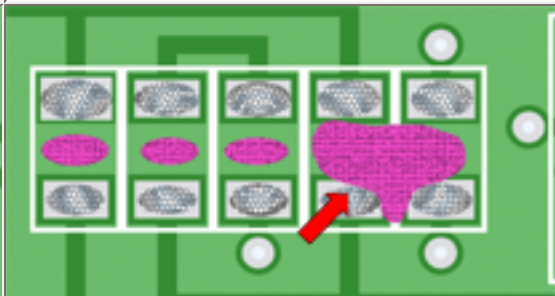

**UNACCEPTABLE
EXCESSIVE ADHESIVE**

Excessive adhesive interferes with proper placement, component retention and solderability.

[NASA-STD-8739.2 \[8.10.3\]](#)

NASA WORKMANSHIP STANDARDS

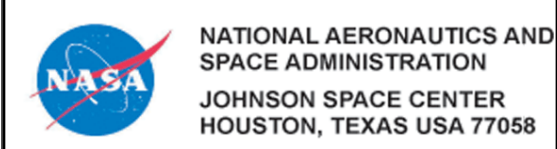

Released: 06.27.2002	Revision:	Revision Date:
-------------------------	-----------	----------------

	Book: 7	Section: 7.03	Page: 1
--	------------	------------------	------------

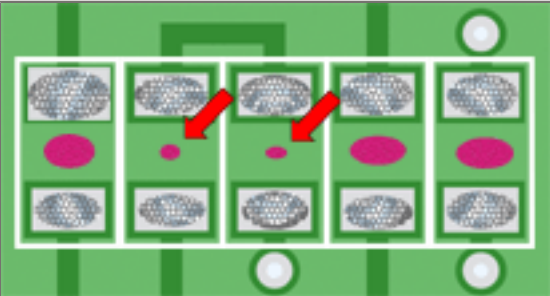
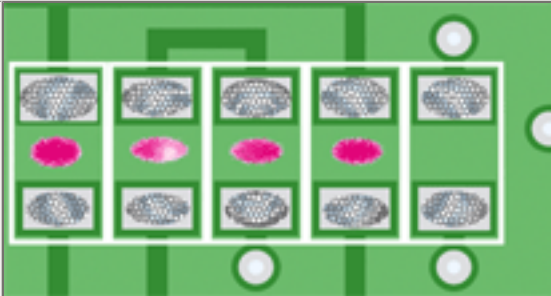
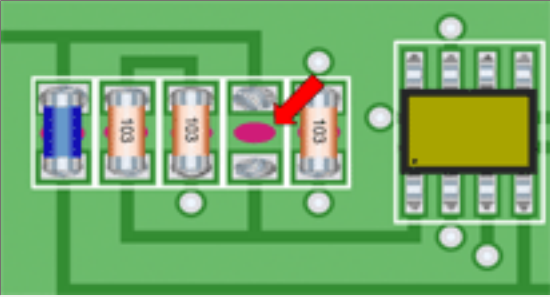
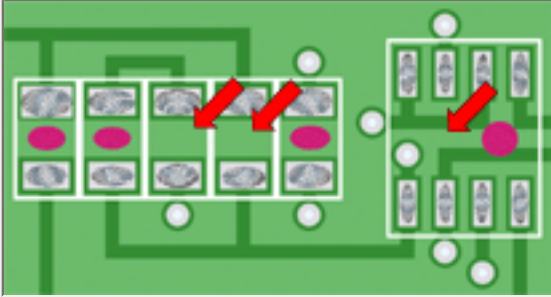
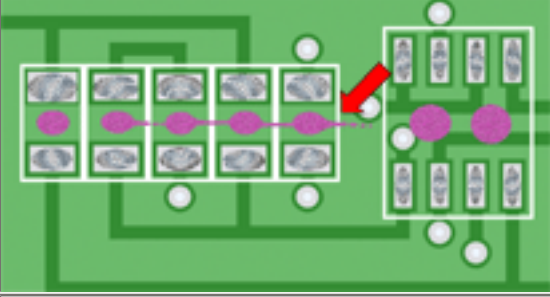
SURFACE MOUNT TECHNOLOGY ADHESIVE APPLICATION(cont.)	
	
<p>UNACCEPTABLE INSUFFICIENT ADHESIVE</p> <p>Insufficient adhesive may result in lost and/or misaligned components and increased rework. NASA-STD-8739.2 [6.15.1], [8.9]</p>	<p>UNACCEPTABLE INSUFFICIENT CURE</p> <p>Insufficiently cured adhesive may result in lost and/or misaligned components and increased rework. NASA-STD-8739.2 [8.9]</p>
	
<p>UNACCEPTABLE LOST COMPONENTS</p> <p>Evidence of lost components indicates a process control problem (excessive/insufficient adhesive, insufficient cure, etc.). NASA-STD-8739.2 [6.15.4]</p>	<p>UNACCEPTABLE SKIPPING</p> <p>Skipping is an indicator of a process control problem and may result in lost components and increased rework. NASA-STD-8739.2 [8.9]</p>
	
<p>UNACCEPTABLE STRINGING</p> <p>Stringing is an indicator of a process control problem, is a contaminant and affects overall solderability. NASA-STD-8739.2 [6.15.1]</p>	

NASA WORKMANSHIP STANDARDS			
 NATIONAL AERONAUTICS AND SPACE ADMINISTRATION JOHNSON SPACE CENTER HOUSTON, TEXAS USA 77058	Released: 06.27.2002	Revision:	Revision Date:
	Book: 7	Section: 7.03	Page: 2



[Need a printed copy?](#)
(May take a while to load.)
Requires Adobe Reader.



[Need Adobe Reader?](#)
[Click here to download.](#)



[Questions? Suggestions?](#)

**SURFACE MOUNT TECHNOLOGY (SMT)
CHIP COMPONENTS BOTTOM-ONLY TERMINATIONS**



**CHIP COMPONENTS
BOTTOM-ONLY TERMINATIONS**

The mechanical properties of the solder joints of bottom-only terminations are slightly reduced from those of 1-2-5 chip components, as only the metallized termination pads on the underside of the component are available for mechanical and electrical attachment to the printed wiring board. The bottom only termination presents some difficulty during visual inspection, as very little of the actual termination is exposed or visible.

See Section 7.01 "Surface Mount Soldering, General Requirements", for common accept/reject criteria.

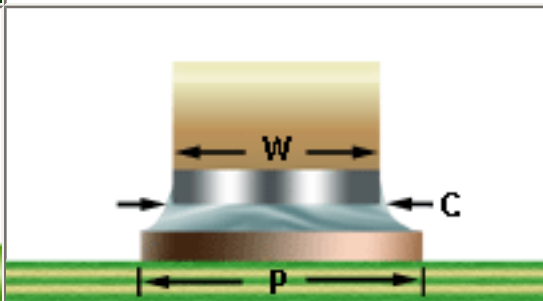

PREFERRED

The component is properly centered between the lands and exhibits acceptable solder thickness and tilt. No mechanical or heat damage is evident.

[NASA-STD-8739.2 \[12.9.1\]](#)

PREFERRED

END JOINT WIDTH (C)

The width of the end joint is equal to the width of the component (W), and extends to the width of the land (P).

[Best Workmanship Practice](#)

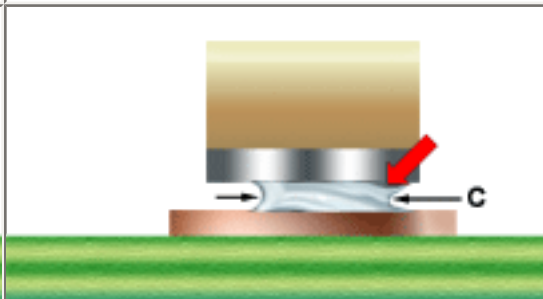
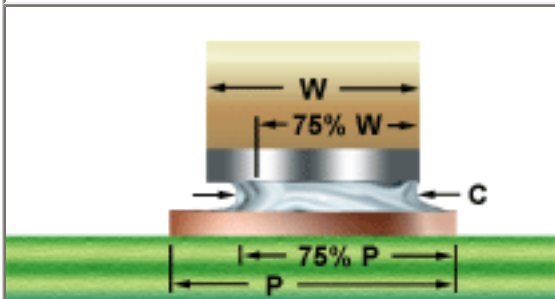

**ACCEPTABLE
END JOINT WIDTH (C)**

End joint width shall not be less than 75% of the component termination width (W) or less than 75% of the land width (P).

[Best Workmanship Practice](#)

UNACCEPTABLE

INSUFFICIENT END JOINT WIDTH (C)

An end joint of insufficient width indicates that there may be solderability problems that may adversely impact the long-term reliability and integrity of the solder termination.

[Best Workmanship Practice](#)

NASA WORKMANSHIP STANDARDS

Released:
06.27.2002

Revision:

Revision Date:



SURFACE MOUNT TECHNOLOGY
CHIP COMPONENTS/BOTTOM-ONLY TERMINATIONS (cont.)

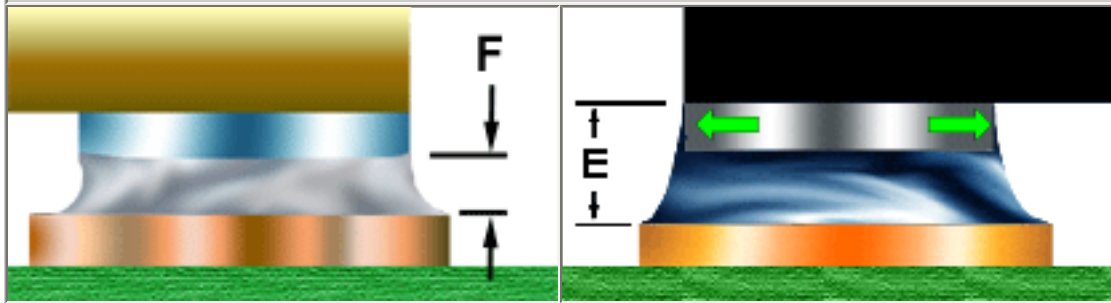

**ACCEPTABLE
MINIMUM FILLET HEIGHT (F)**

There shall be evidence of a properly wetted fillet on the exposed sides of the termination.

[NASA-STD-8739.2 \[12.9.1.a\]](#)

**PREFERRED
MAXIMUM FILLET HEIGHT (E)**

The fillet shall exhibit a positive wetting angle and shall not contact the component body.

[NASA-STD-8739.2 \[12.8.1\], \[12.8.2.b.12\], \[12.9.1.a\]](#)

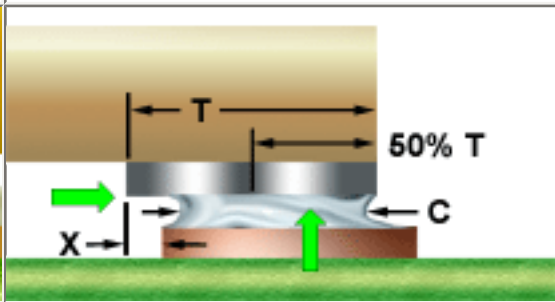
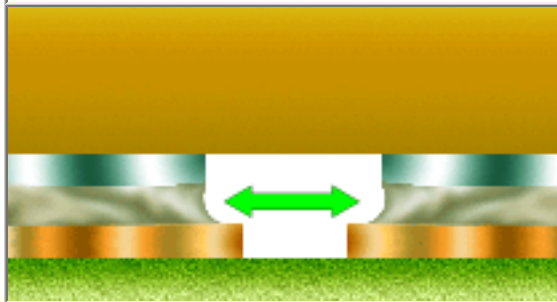

**PREFERRED
INSIDE OVERHANG**

The target condition is the component centered between the termination pads, without the inside edges of the metallized pads overhanging the edges of the termination pads.

[NASA-STD-8739.2 \[8.7.4.g.2\]](#)

**ACCEPTABLE
INSIDE OVERHANG (X)**

Inside overhang (X) shall be less than or equal to 50% of the end termination width (T) and the minimum end joint width (C) requirements shall be met.

[NASA-STD-8739.2 \[8.7.4.g.2\]](#)

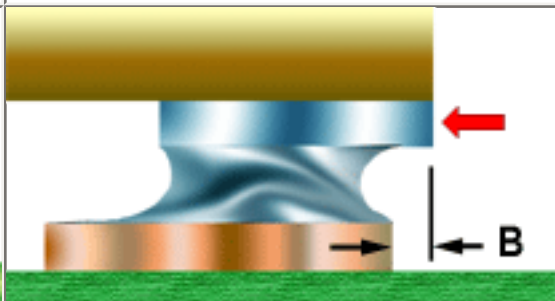
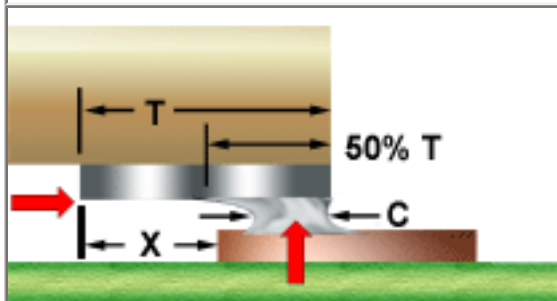

<p>UNACCEPTABLE EXCESS INSIDE OVERHANG (X)</p> <p>Inside overhang shall not exceed 50% of the end termination width (T) and the minimum end joint width (C) requirements shall be met.</p> <p>NASA-STD-8739.2 [12.6.2.a.2]</p>	<p>UNACCEPTABLE END OVERHANG (B)</p> <p>Overhang of the chip's metallization (pad) beyond the outside edge of the termination pad is not permitted.</p> <p>Best Workmanship Practice</p>
---	---

NASA WORKMANSHIP STANDARDS			
 <p>NATIONAL AERONAUTICS AND SPACE ADMINISTRATION JOHNSON SPACE CENTER HOUSTON, TEXAS USA 77058</p>	Released: 06.27.2002	Revision:	Revision Date:
	Book: 7	Section: 7.04	Page: 2

SURFACE MOUNT TECHNOLOGY (SMT)
CHIP COMPONENTS/BOTTOM-ONLY TERMINATIONS (cont.)

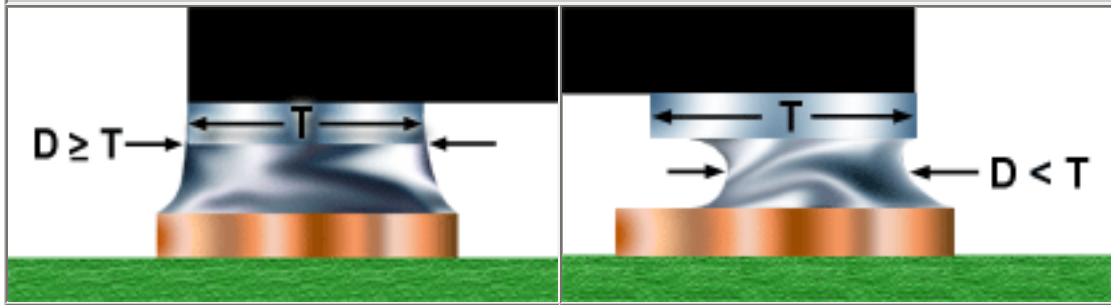

<p>PREFERRED SIDE JOINT LENGTH (D)</p> <p>The length of the side joint fillet equals or exceeds the component termination pad length (T).</p> <p>Best Workmanship Practice</p>	<p>ACCEPTABLE SIDE JOINT LENGTH (D)</p> <p>Any side joint length is acceptable, provided there is evidence of a side joint, and all other joint parameters are met.</p> <p>Best Workmanship Practice</p>
---	---

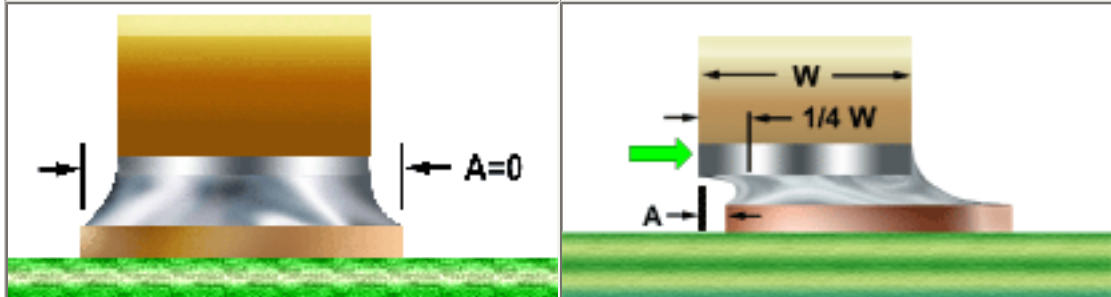

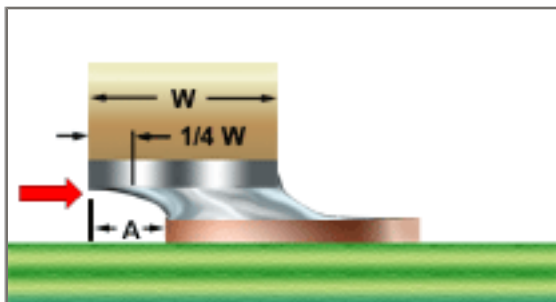
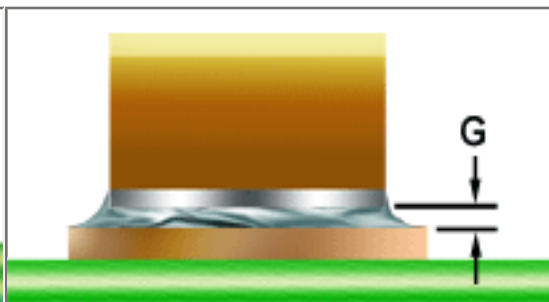

<p>PREFERRED SIDE/LATERAL OVERHANG (A)</p> <p>The component is centered on the pads, with no side/lateral overhang (A).</p> <p>NASA-STD-8739.2 [8.7.4.g.1]</p>	<p>ACCEPTABLE SIDE/LATERAL OVERHANG (A)</p> <p>Side overhang shall not exceed 25% of the part width (W) and the minimum end joint width (C) requirements shall be met.</p> <p>NASA-STD-8739.2 [8.7.4.g.1]</p>
---	--

	
<p style="text-align: center;">UNACCEPTABLE</p> <p style="text-align: center;">EXCESS SIDE/LATERAL OVERHANG (A)</p> <p>Side overhang in excess of 25% of the part width (W) and/or the minimum end joint width (C) may impact the long-term reliability and integrity of the solder termination.</p> <p>NASA-STD-8739.2 [12.9.1.b.7]</p>	<p style="text-align: center;">ACCEPTABLE</p> <p style="text-align: center;">MINIMUM SOLDER THICKNESS (G)</p> <p>The solder quantity shall be sufficient to form a properly wetted, concave fillet on the vertical surfaces of the chip, and which exhibits good wetting to the chip metallization and termination pad.</p> <p>NASA-STD-8739.2 [12.8.1.b], [12.9.1.a]</p>

NASA WORKMANSHIP STANDARDS

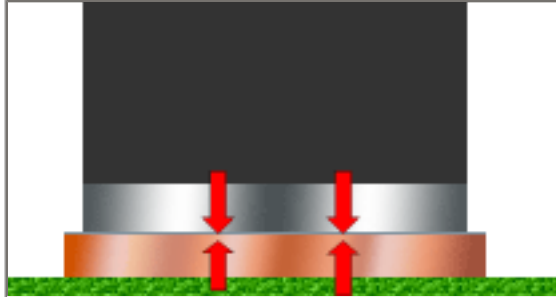
 <p>NATIONAL AERONAUTICS AND SPACE ADMINISTRATION JOHNSON SPACE CENTER HOUSTON, TEXAS USA 77058</p>	Released: 06.27.2002	Revision:	Revision Date:
	Book: 7	Section: 7.04	Page: 3

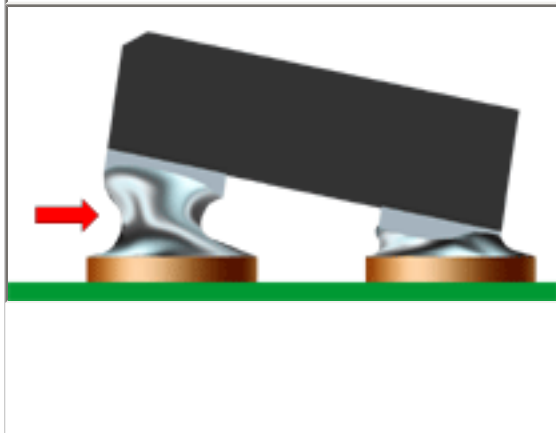
SURFACE MOUNT TECHNOLOGY (SMT) CHIP COMPONENTS/BOTTOM-ONLY COMPONENTS (cont.)	
	
<p style="text-align: center;">UNACCEPTABLE</p> <p style="text-align: center;">INSUFFICIENT SOLDER THICKNESS (G)</p> <p>The solder quantity is insufficient to form a properly wetted, concave fillet which exhibits good wetting to the chip metallization and termination pad.</p> <p>NASA-STD-8739.2 [12.9.1.b.5]</p>	<p style="text-align: center;">ACCEPTABLE</p> <p style="text-align: center;">TILT</p> <p>Part tilt shall be less than or equal to 25% of the part thickness, and shall not interfere with the proper placement of adjacent parts.</p> <p>NASA-STD-8739.2 [12.6.2], [12.9.1]</p>
	

**UNACCEPTABLE
EXCESS TILT**

Part tilt in excess of 25% of the part thickness may impact the long-term reliability and integrity of the solder termination, and may interfere with the proper placement and thermal profile of adjacent parts.

[NASA-STD-8739.2 \[12.9.1.b.1\], \[12.9.1.b.2\]](#)

NASA WORKMANSHIP STANDARDS			
 NATIONAL AERONAUTICS AND SPACE ADMINISTRATION JOHNSON SPACE CENTER HOUSTON, TEXAS USA 77058	Released: 06.27.2002	Revision:	Revision Date:
	Book: 7	Section: 7.04	Page: 4



[Need a printed copy?](#)
(May take a while to load.)
 Requires Adobe Reader.



[Need Adobe Reader?](#)
[Click here to download.](#)



[Questions? Suggestions?](#)

**SURFACE MOUNT TECHNOLOGY (SMT)
CHIP COMPONENTS-RECTANGULAR/SQUARE END TERMINATIONS**

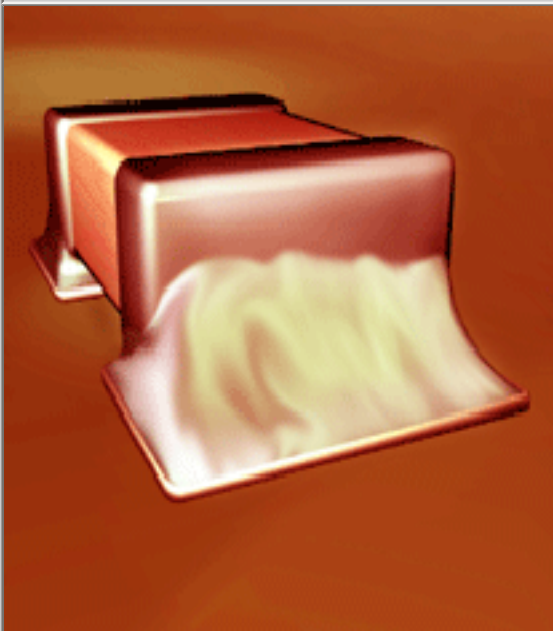

**SURFACE MOUNT TECHNOLOGY (SMT)
SHIP COMPONENTS-
RECTANGULAR/
SQUARE END TERMINATIONS
(1-3-5 SIDED)**

Rectangular and square-end ship components are characterized by their metallized termination cap design. Unlike their bottom-only termination cousins, the standard chip may be supplied with metallization on the end surfaces (1-sided); the bottom, end and top surfaces (3-sided); or, the bottom, end, top and sides of the termination cap (5-sided).

See Section 7.01 "Surface Mount Soldering, General Requirements", for common accept/reject criteria.

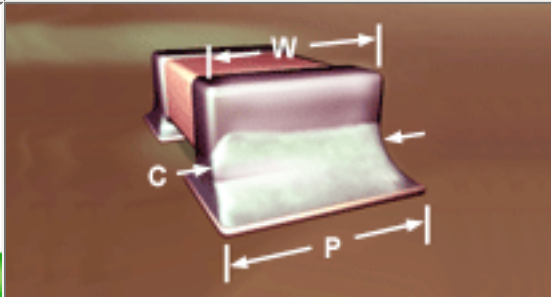
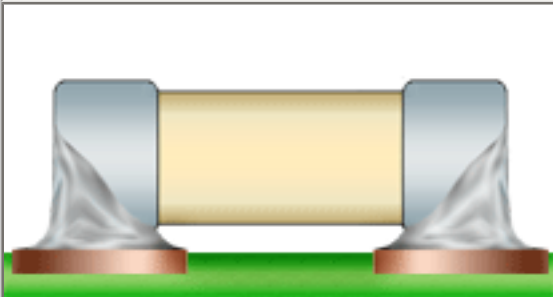

PREFERRED

Device is centered on the termination pads, with proper end overlap and no inside overhang. The solder termination exhibits a full concave fillet on their vertical terminal faces, with evidence of good wetting to the chip metallization and extends to the periphery of the land.

[NASA-STD-8739.2 \[8.7.4.g\], \[12.9.1.a\]](#)

**PREFERRED
END JOINT WIDTH (C)**

The End Joint Width (C) shall be equal to or greater than the component width (W) or width of the land (P), whichever is less.

[Best Workmanship Practice](#)

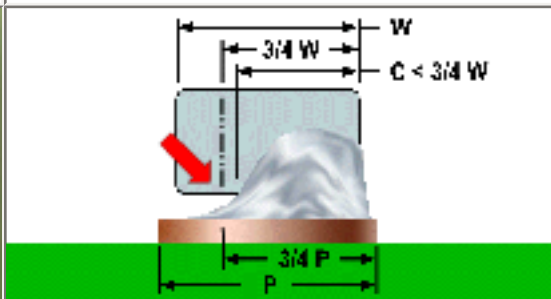
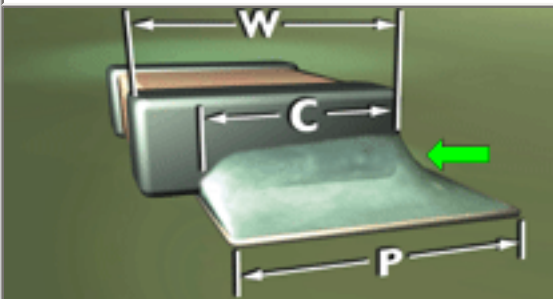

**ACCEPTABLE
END JOINT WIDTH (C)**

The End Joint Width (C) shall be 75% of the component width (W) or width of the land (P), whichever is less.

[Best Workmanship Practice](#)

**UNACCEPTABLE
END JOINT WIDTH (C)**

The width of the end joint shall not be less than 75% of the component termination width (W), or 75% of the land width (P), whichever is less.

[Best Workmanship Practice](#)

NASA WORKMANSHIP STANDARDS

Released:
06.27.2002

Revision:

Revision Date:



NATIONAL AERONAUTICS AND SPACE ADMINISTRATION
 JOHNSON SPACE CENTER
 HOUSTON, TEXAS USA 77058

Book:
7

Section:
7.05

Page:
1

SURFACE MOUNT TECHNOLOGY
 CHIP COMPONENTS-RECTANGULAR/SQUARE END TERMINATIONS
 (cont.)

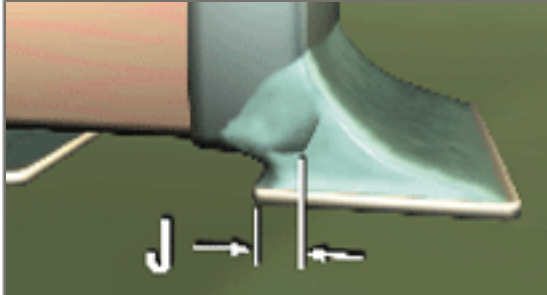

ACCEPTABLE
 END OVERLAP (J)

There shall be end overlap (J) between the component termination cap and the termination pad. Preferentially, the end overlap (J) should equal the termination cap length, with the component centered between the pads.

[Best Workmanship Practice](#)

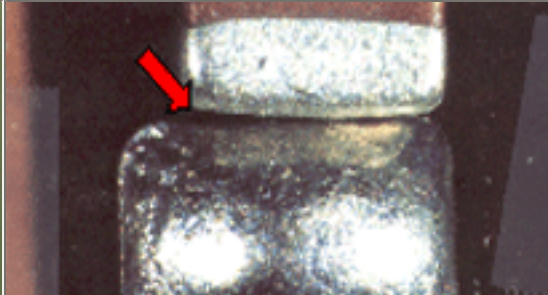

UNACCEPTABLE
 INSUFFICIENT END OVERLAP (J)

There shall be end overlap (J) between the component termination cap and the termination pad to ensure the proper formation of the solder fillet.

[Best Workmanship Practice](#)

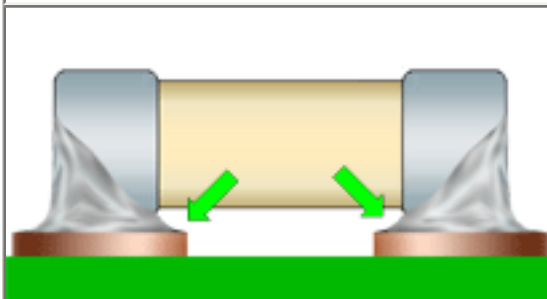

PREFERRED
 INSIDE OVERHANG

The target condition is the component centered between the termination pads, without the inside edge(s) of the metallization pads overhanging the termination pad(s).

[NASA-STD-8739.2 \[8.7.4.g.2\]](#)

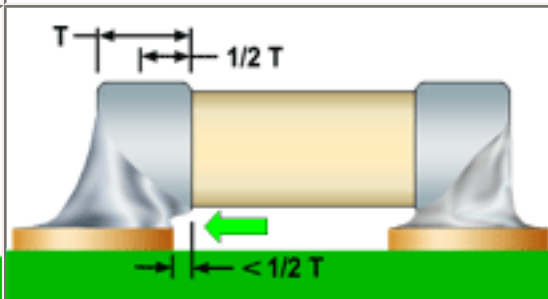

ACCEPTABLE
 INSIDE OVERHANG

Inside overhang of the ship's metallization pad shall be less than or equal to 50% of the end termination width (T) and the minimum end joint width (C) requirements shall be met.

[NASA-STD-8739.2 \[8.7.4.g.2\]](#)

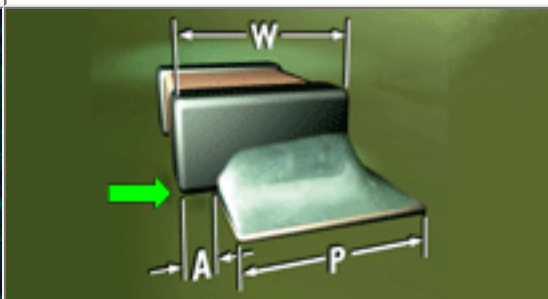
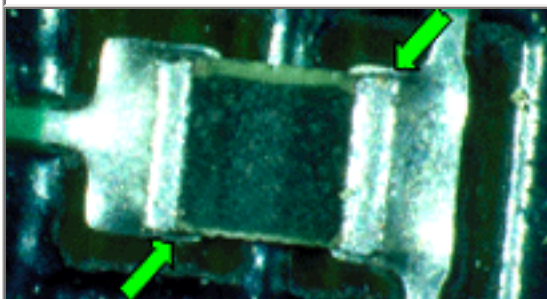

<p>PREFERRED LATERAL/SIDE OVERHANG (A)</p> <p>The target condition is no lateral/side overhang, with the component centered on the land.</p> <p>NASA-STD-8739.2 [8.7.4.g.1]</p>	<p>ACCEPTABLE LATERAL/SIDE OVERHANG (A)</p> <p>Lateral/side overhang (A) shall not exceed 25% of the component termination area (W) or land width (P), whichever is smaller.</p> <p>NASA-STD-8739.2 [8.7.4.g.1]</p>
--	--

NASA WORKMANSHIP STANDARDS

 <p>NATIONAL AERONAUTICS AND SPACE ADMINISTRATION</p> <p>JOHNSON SPACE CENTER HOUSTON, TEXAS USA 77058</p>	Released: 06.27.2002	Revision:	Revision Date:
	Book: 7	Section: 7.05	Page: 2

**SURFACE MOUNT TECHNOLOGY (SMT)
CHIP COMPONENTS-RECTANGULAR/SQUARE END TERMINATIONS
(cont.)**

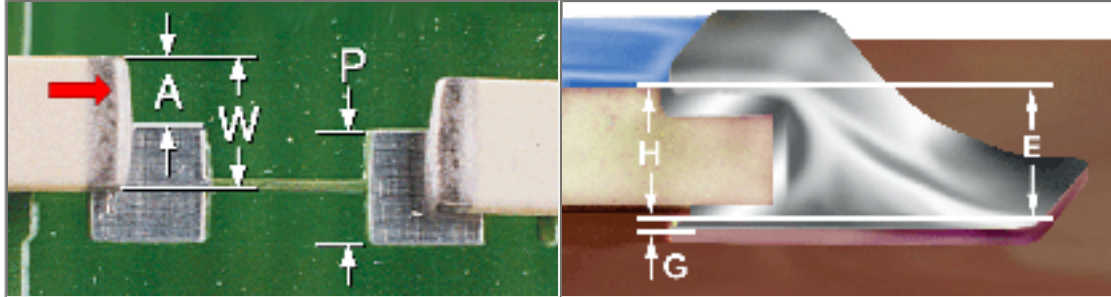

**UNACCEPTABLE
EXCESS LATERAL/SIDE OVERHANG (A)**

The component shall not hang over the edge of the termination land by more than 25% of the component termination area (W), or 25% of the land width (P), whichever is less.

[NASA-STD-8739.2 \[12.9.1.b.7\]](#)

**PREFERRED
MAXIMUM FILLET HEIGHT (E)**

The maximum fillet height shall be the solder thickness (G) plus the component termination height (H).

[NASA-STD-8739.2 \[12.9.1.a\]](#)

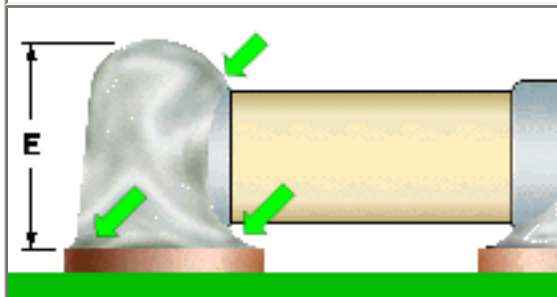

**ACCEPTABLE
MAXIMUM FILLET HEIGHT (E)**

The fillet may extend over the top of the end cap metallization, provided the fillet exhibits a positive wetting angle, and does not contact the component body.

[NASA-STD-8739.2 \[12.9.1.a\]](#)

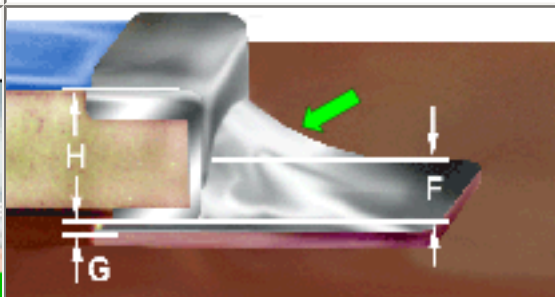

**ACCEPTABLE
MINIMUM FILLET HEIGHT (F)**

The minimum fillet height shall be equal to or greater than the minimum solder thickness (G), plus 50% of the component termination height (H).

[NASA-STD-8739.2 \[12.9.1.b.3\]](#)

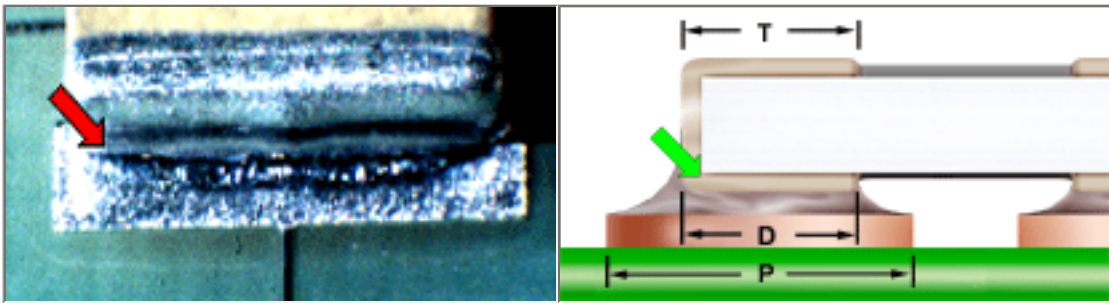

<p style="text-align: center;">UNACCEPTABLE</p> <p style="text-align: center;">INSUFFICIENT FILLET HEIGHT (F)</p> <p>There shall be evidence of a properly wetted fillet between the chip and the land.</p> <p>NASA-STD-8739.2 [12.9.1.b.3], [12.9.1.b.5]</p>	<p style="text-align: center;">ACCEPTABLE</p> <p style="text-align: center;">SIDE JOINT LENGTH (D)</p> <p>The side joint length should be equal to the End Termination Length (T) and should extend to the periphery of the termination pad (P).</p> <p>Best Workmanship Practice</p>
---	---

NASA WORKMANSHIP STANDARDS

 <p>NATIONAL AERONAUTICS AND SPACE ADMINISTRATION JOHNSON SPACE CENTER HOUSTON, TEXAS USA 77058</p>	Released: 06.27.2002	Revision:	Revision Date:
	Book: 7	Section: 7.05	Page: 3

**SURFACE MOUNT TECHNOLOGY (SMT)
CHIP COMPONENTS-RECTANGULAR/SQUARE END TERMINATIONS
(cont.)**

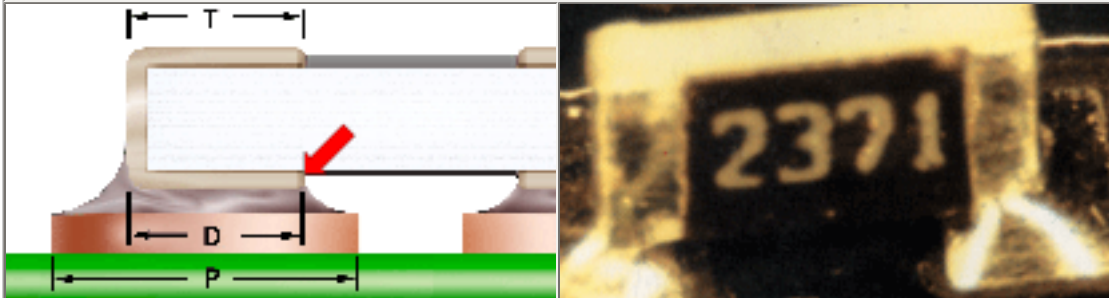

<p style="text-align: center;">UNACCEPTABLE</p> <p style="text-align: center;">SIDE JOINT LENGTH (D)</p> <p>Although the solder fillet exhibits good wetting, the side joint length (D) is less than the End Termination Length (T), and does not extend to the periphery of the termination pad (P).</p> <p>Best Workmanship Practice</p>	<p style="text-align: center;">UNACCEPTABLE</p> <p style="text-align: center;">SIDE MOUNT</p> <p>The mounting of chip components on their side is prohibited.</p> <p>NASA-STD-8739.2 [12.8.2.a.2]</p>
--	---

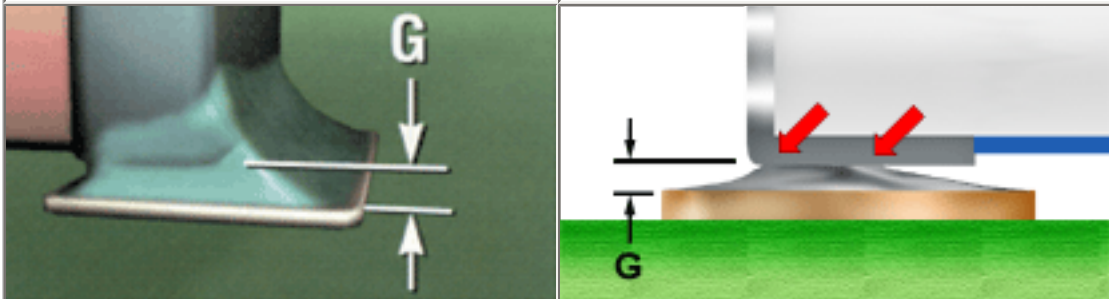

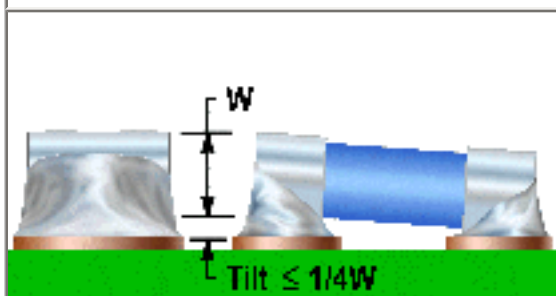
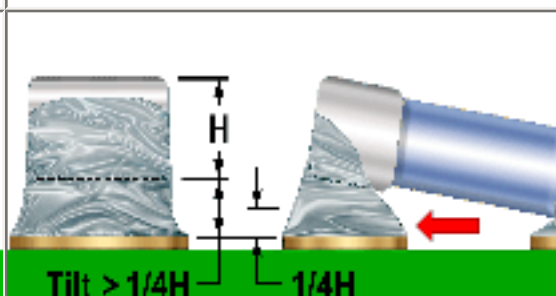

<p style="text-align: center;">ACCEPTABLE SOLDER THICKNESS (G)</p> <p>The solder quantity shall be sufficient to form a properly wetted, concave fillet on the vertical surfaces of the chip, and which exhibits good wetting to the chip metallization and termination pad.</p> <p>NASA-STD-8739.2 [12.8.1.b], [12.9.1.a]</p>	<p style="text-align: center;">UNACCEPTABLE INSUFFICIENT SOLDER THICKNESS (G)</p> <p>The solder quantity is insufficient to form a properly wetted, concave fillet which exhibits good wetting to the chip metallization and termination pad.</p> <p>NASA-STD-8739.2 [12.9.1.b.5]</p>
	
<p style="text-align: center;">ACCEPTABLE TILT</p> <p>Part tilt shall not exceed 25% of the part thickness (H), and shall not interfere with the proper placement of adjacent parts.</p> <p>NASA-STD-8739.2 [12.6.2.a.3]</p>	<p style="text-align: center;">UNACCEPTABLE EXCESS TILT</p> <p>Part tilt shall not exceed 25% of the component thickness (H), and shall not interfere with the proper placement of adjacent parts, or violate minimum electrical spacing requirements.</p> <p>NASA-STD-8739.2 [12.9.1.b.1], [12.9.1.b.2]</p>

NASA WORKMANSHIP STANDARDS

 <p>NATIONAL AERONAUTICS AND SPACE ADMINISTRATION JOHNSON SPACE CENTER HOUSTON, TEXAS USA 77058</p>	Released: 06.27.2002	Revision:	Revision Date:
	Book: 7	Section: 7.05	Page: 4

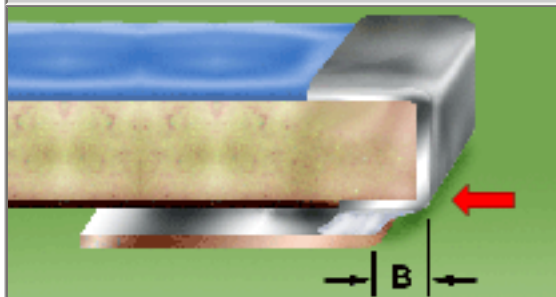
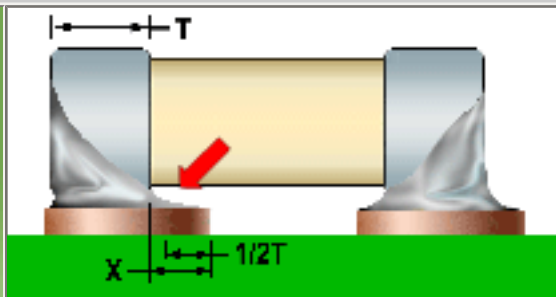
**SURFACE MOUNT TECHNOLOGY (SMT)
CHIP COMPONENTS-RECTANGULAR/SQUARE END TERMINATIONS
(cont.)**

	
<p style="text-align: center;">UNACCEPTABLE END OVERHANG (B)</p> <p>End overhang is not permitted.</p> <p>Best Workmanship Practice</p>	<p style="text-align: center;">UNACCEPTABLE EXCESS INSIDE OVERLAP (X)</p> <p>Inside overlap (X) shall not exceed 50% of the End Termination Length (T).</p> <p>NASA-STD-8739.2 [12.9.1.b.8]</p>

NASA WORKMANSHIP STANDARDS			
 NATIONAL AERONAUTICS AND SPACE ADMINISTRATION JOHNSON SPACE CENTER HOUSTON, TEXAS USA 77058	Released: 06.27.2002	Revision:	Revision Date:
	Book: 7	Section: 7.05	Page: 5



[Need a printed copy?](#)
(May take a while to load.)
Requires Adobe Reader.



[Need Adobe Reader?](#)
[Click here to download.](#)



[Questions? Suggestions?](#)

SURFACE MOUNT TECHNOLOGY (SMT)
METALLIZED ELECTRODE FACE-MELF

METALLIZED ELECTRODE FACE (MELF)



The Metallized Electrode Face (MELF) termination is characterized as a cylindrical package with metallized end caps, and is commonly used for the packaging of discrete diodes, capacitors and resistors. Since they are cylindrical, the MELF does not have to be placed with the resistive elements facing away from the board surface, as is the case with rectangular chip packages. Like their through-hole axial cousins, MELFs are typically color-coded for value.

See Section 7.01 "Surface Mount Soldering, General Requirements", for common accept/reject criteria.

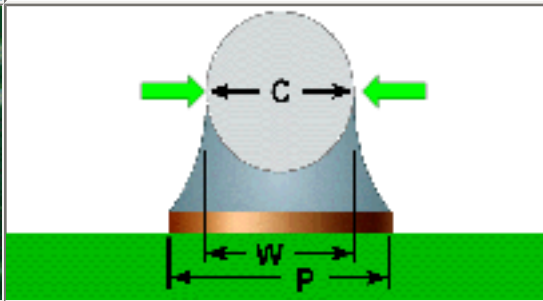
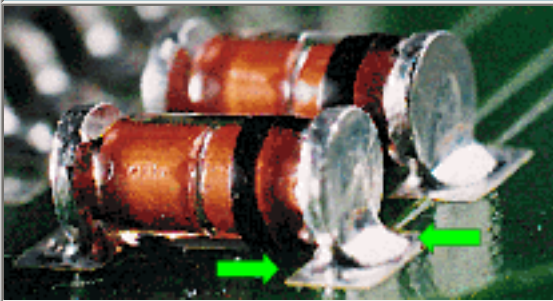

PREFERRED

The termination exhibits a concave fillet on the terminal faces, with evidence of good wetting to the metallization and the periphery of the land.

[NASA-STD-8739.2 \[8.7.4\], \[12.9.6\]](#)

**PREFERRED
END JOINT WIDTH (C)**

The End Joint Width (C) shall be equal to or greater than the component width (W) or width of the land (P), whichever is less.

[Best Workmanship Practice](#)

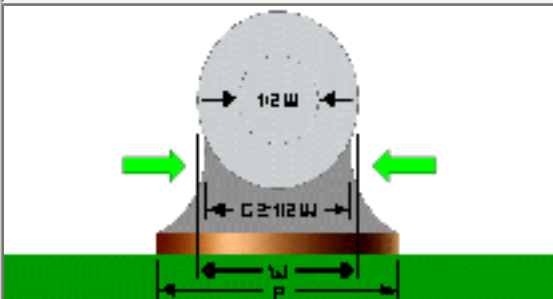

**ACCEPTABLE
END JOINT WIDTH (C)**

The End Joint Width (C) shall be $\geq 50\%$ of the component width (W) or width of the land (P), whichever is less.

[Best Workmanship Practice](#)

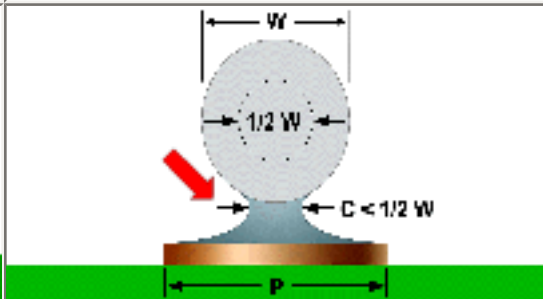

**UNACCEPTABLE
INSUFFICIENT END JOINT WIDTH (C)**

The width of the end joint shall not be less than 50% of the component termination width (W), or land width (P), whichever is less.

[Best Workmanship Practice](#)

NASA WORKMANSHIP STANDARDS

Released:
06.27.2002

Revision:

Revision Date:



SURFACE MOUNT TECHNOLOGY
 METALLIZED ELECTRODE FACE - MELF(cont.)

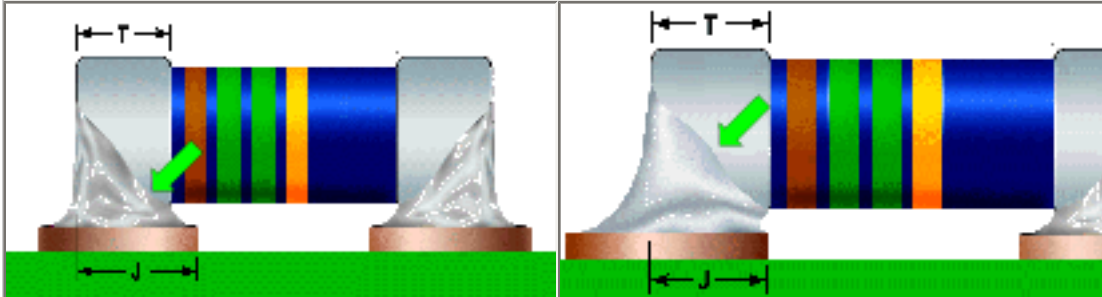

PREFERRED
 END OVERLAP (J)

The component should be positioned such that the termination caps are centered between the termination pads, resulting in fillet formation on all edges of the metallization. End overlap (J) should be greater than the termination cap length (T).

[Best Workmanship Practice](#)

ACCEPTABLE
 END OVERLAP (J)

The termination cap shall overlap the land by at least 75% of the termination cap length (T). Example shows the inside edge of the termination cap even with the land/pad edge, with end overlap (J) equal to the termination cap length.

[Best Workmanship Practice](#)

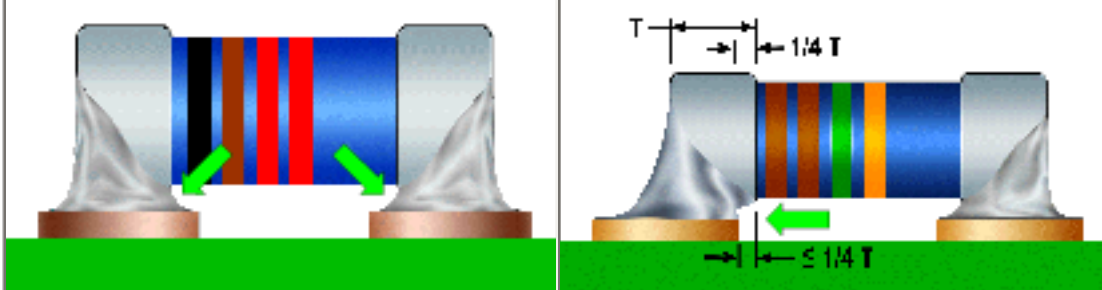

PREFERRED
 INSIDE OVERHANG

The component is centered between the pads, with no portion of the termination cap overhanging the inside edges of the solder termination pads.

[NASA-STD-8739.2 \[8.7.4.\], \[12.9.6\]](#)

ACCEPTABLE
 INSIDE OVERHANG

Inside overhang shall be less than or equal to 25% of the component termination length (T).

[NASA-STD-8739.2 \[8.7.4.\], \[12.6.2.a.8\]](#)

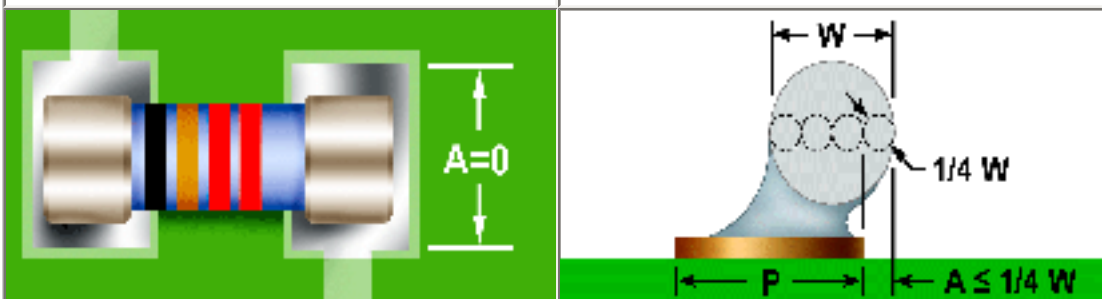

A=0

1/4 W

A ≤ 1/4 W

<p>PREFERRED LATERAL/SIDE OVERHANG (A)</p> <p>The target condition is no lateral/side overhang, with the component centered on the land.</p> <p>NASA-STD-8739.2 [8.7.4.I]</p>	<p>ACCEPTABLE LATERAL/SIDE OVERHANG (A)</p> <p>Lateral/side overhang (A) shall not exceed 25% of the component diameter (W) or land width (P), whichever is smaller.</p> <p>NASA-STD-8739.2 [8.7.4.I], [12.6.2.a.8]</p>
--	--

NASA WORKMANSHIP STANDARDS			
 <p>NATIONAL AERONAUTICS AND SPACE ADMINISTRATION JOHNSON SPACE CENTER HOUSTON, TEXAS USA 77058</p>	Released:	Revision:	Revision Date:
	Book:	Section:	Page:
	06.27.2002		
	7	7.06	2

**SURFACE MOUNT TECHNOLOGY (SMT)
METALLIZED ELECTRODE FACE - MELF (cont.)**

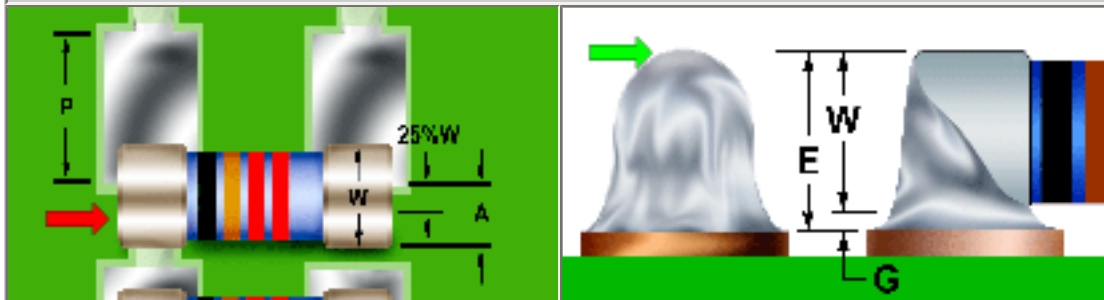

**UNACCEPTABLE
EXCESS LATERAL/SIDE OVERHANG (A)**

The component shall not hang over the edge of the termination land by more than 25% of the component diameter area (W), or land width (P), whichever is less.

[NASA-STD-8739.2 \[12.9.6.b.1\]](#)

**PREFERRED
MAXIMUM FILLET HEIGHT (E)**

The maximum height of the solder fillet is 100% of the component diameter (W), plus solder thickness (G). The solder fillet exhibits full wetting, with positive angles, and does not extend over the top surface of the component cap.

[NASA-STD-8739.2 \[12.9.6.a\]](#)

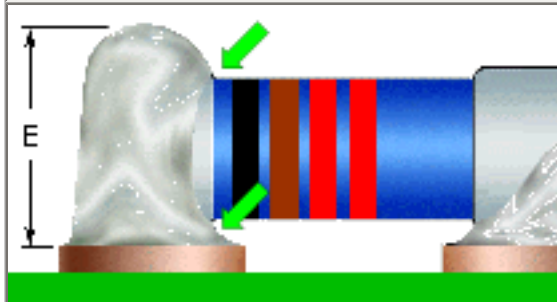

**ACCEPTABLE
MAXIMUM FILLET HEIGHT (E)**

The fillet may extend over the top of the end cap metallization, provided the fillet exhibits a positive wetting angle, and does not contact the part body.

[NASA-STD-8739.2 \[12.9.6.a\]](#)

**UNACCEPTABLE
TERMINATION CONTOUR IS NOT
DISCERNABLE**

The contour of the termination shall be discernable in the solder fillet.

[NASA-STD-8739.2 \[12.9.6.b.5\]](#)

<p align="center">PREFERRED MINIMUM FILLET HEIGHT (F)</p> <p>The minimum height of the solder fillet shall be $\geq 50\%$ of the component diameter (W) plus the solder thickness (G), and shall extend the entire width of the part contact area.</p> <p>Best Workmanship Practice</p>	<p align="center">ACCEPTABLE MINIMUM FILLET HEIGHT (F)</p> <p>The solder thickness shall be sufficient to exhibit a properly wetted fillet, and complete solder flow under the component end cap.</p> <p>NASA-STD-8739.2 [12.8.1.b], [12.9.6.a]</p>

NASA WORKMANSHIP STANDARDS			
<p>NATIONAL AERONAUTICS AND SPACE ADMINISTRATION JOHNSON SPACE CENTER HOUSTON, TEXAS USA 77058</p>	Released: 06.27.2002	Revision:	Revision Date:
	Book: 7	Section: 7.06	Page: 3

SURFACE MOUNT TECHNOLOGY (SMT) METALLIZED ELECTRODE FACE - MELF (cont.)	
<p align="center">UNACCEPTABLE INSUFFICIENT SOLDER</p> <p>There shall be evidence of complete solder flow and wetting under the component end cap.</p> <p>NASA-STD-8739.2 [12.9.6.b.4]</p>	<p align="center">PREFERRED SIDE FILLET LENGTH (D)</p> <p>The side fillet should be equal to the End Termination Length (T), or Land Width (P), whichever is less.</p> <p>Best Workmanship Practice</p>

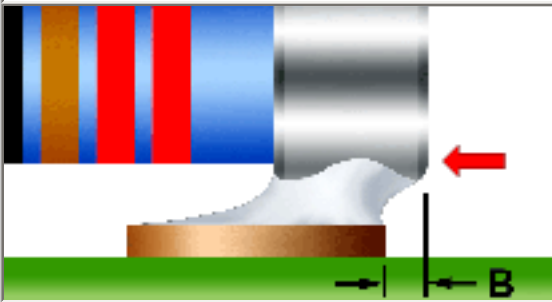
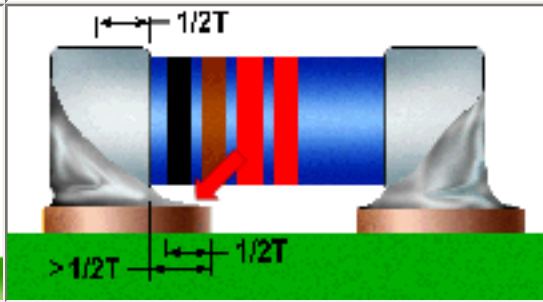
<p style="text-align: center;">ACCEPTABLE SIDE FILLET LENGTH (D)</p> <p>The side fillet shall be greater than or equal to the End Termination Length (T) or land width (P), whichever is less.</p> <p>NASA-STD-8739.2 [12.9.6.b.2]</p>	<p style="text-align: center;">UNACCEPTABLE INSUFFICIENT SIDE FILLET (D)</p> <p>The side fillet shall be \geq to 75% of the End Termination Length (T) or land width (P), whichever is less.</p> <p>Best Workmanship Practice</p>
	
<p style="text-align: center;">UNACCEPTABLE END OVERHANG (B)</p> <p>The end of the component termination cap should not extend beyond the outside edge of the termination pad.</p> <p>Best Workmanship Practice</p>	<p style="text-align: center;">UNACCEPTABLE EXCESS INSIDE OVERLAP</p> <p>The component body should not overlap the termination pad in excess of 50% of the End Termination Length (T).</p> <p>Best Workmanship Practice</p>

NASA WORKMANSHIP STANDARDS

 <p>NATIONAL AERONAUTICS AND SPACE ADMINISTRATION JOHNSON SPACE CENTER HOUSTON, TEXAS USA 77058</p>	<p>Released: 06.27.2002</p>	<p>Revision:</p>	<p>Revision Date:</p>
	<p>Book: 7</p>	<p>Section: 7.06</p>	<p>Page: 4</p>



[Need a printed copy?](#)
(May take a while to load.)
Requires Adobe Reader.



[Need Adobe Reader?](#)
[Click here to download.](#)



[Questions? Suggestions?](#)

SURFACE MOUNT TECHNOLOGY (SMT)
GULL-WING/"L" LEADED PACKAGES

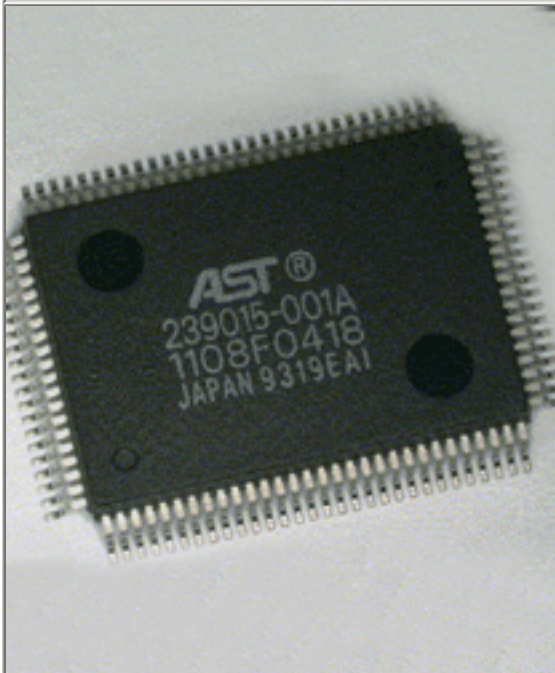

GULL-WING/"L" LEADED PACKAGES

Gull-Wing IC package leads are formed in a profile very similar to the outline of a seagull's wings. The Gull-Wing is considered one of the most reliable terminations for fine-pitch, high pin-count packages.

"L" leaded IC packages have leads formed in a configuration very similar to the outline of the letter "L". The leads are shorter (length and height) than the "Gull-Wing" and tend to be much stiffer (hardened).

See Section 7.01 "Surface Mount Soldering, General Requirements", for common accept/reject criteria.



PREFERRED

The part is properly oriented to the land pattern, with each lead centered across the width of the land. Leads are planar, fillets are shiny and concave, and heel fillet is evident.

[NASA-STD-8739.2 \[8.7.4.h\]](#), [\[12.6.2\]](#), [\[12.8\]](#)

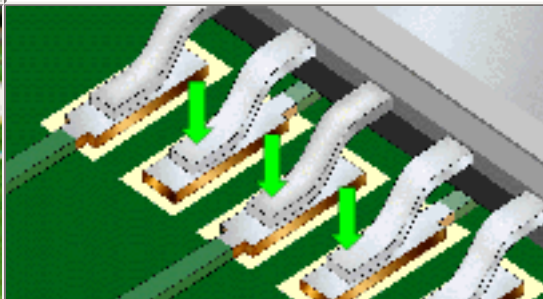

PREFERRED COPLANARITY

The preferred planarity of the lead to the land pattern area is with the foot parallel and in full contact with the pad.

[NASA-STD-8739.2 \[7.1\]](#)

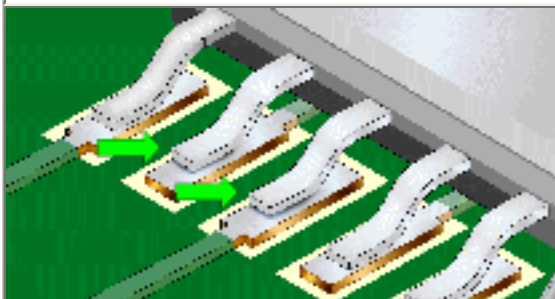

ACCEPTABLE COPLANARITY

The maximum acceptable non-planarity between any portion of the lead foot and the pad shall not exceed 0.26 mm (0.010").

[NASA-STD-8739.2 \[7.1\]](#), [\[12.9.2.b.3\]](#)





UNACCEPTABLE IMPROPER COPLANARITY

The maximum acceptable non-planarity between any portion of the lead foot and the pad shall not exceed 0.26 mm (0.010").

[NASA-STD-8739.2 \[12.9.2.b.3\]](#)

NASA WORKMANSHIP STANDARDS

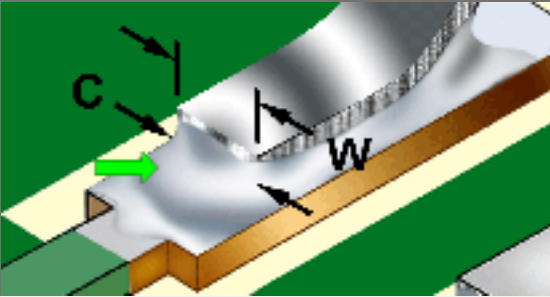
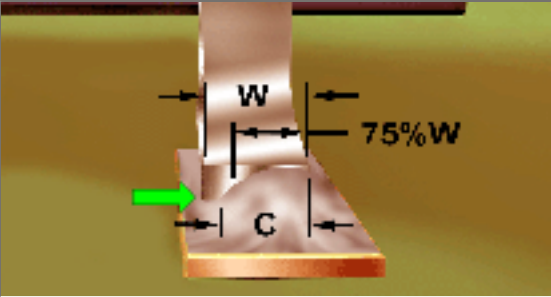
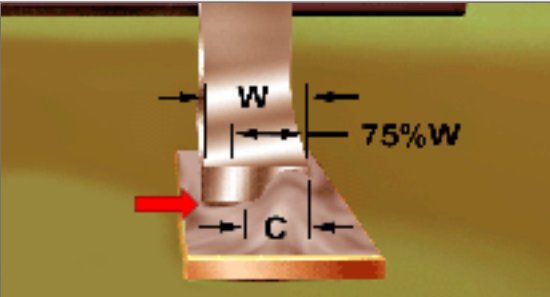
 NATIONAL AERONAUTICS AND SPACE ADMINISTRATION JOHNSON SPACE CENTER HOUSTON, TEXAS USA 77058	Released: 06.27.2002	Revision:	Revision Date:
	Book: 7	Section: 7.07	Page: 1

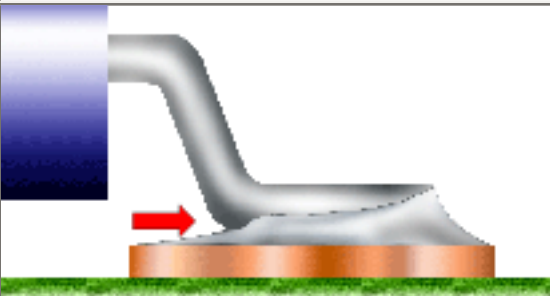
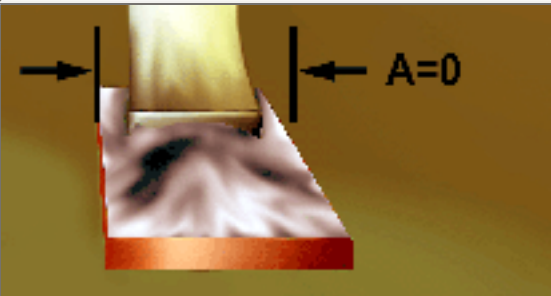
SURFACE MOUNT TECHNOLOGY GULL-WING/"L" LEADED PACKAGES (cont.)	
	
<p>PREFERRED END JOINT WIDTH (C)</p> <p>The width of the end joint (C) should be greater than or equal to the lead width (W).</p> <p>Best Workmanship Practice</p>	<p>ACCEPTABLE END JOINT WIDTH (C)</p> <p>The width of the end joint shall be greater than or equal to 75% of the lead width (W).</p> <p>Best Workmanship Practice</p>
	
<p>UNACCEPTABLE INSUFFICIENT END JOINT WIDTH (C)</p> <p>The width of the end joint (C) is less than 75% of the lead width (W).</p> <p>Best Workmanship Practice</p>	<p>MANDATORY HEEL FILLET</p> <p>A heel fillet is mandatory and the contour shall be positive.</p> <p>NASA-STD-8739.2 [12.9.2.b.5]</p>
	

<p>UNACCEPTABLE MISSING HEEL FILLET</p> <p>A missing heel fillet is an indicator of improper process, and may impact the long-term reliability and integrity of the solder termination. A heel fillet is mandatory and the contour shall be positive.</p> <p>NASA-STD-8739.2 [12.9.2.b.5]</p>	<p>PREFERRED LATERAL/SIDE OVERHANG (A)</p> <p>The target condition is no lateral/side overhang (A), with the component lead centered on the land.</p> <p>NASA-STD-8739.2 [8.7.4.h], [12.6.2]</p>
--	---

NASA WORKMANSHIP STANDARDS			
 <p>NATIONAL AERONAUTICS AND SPACE ADMINISTRATION JOHNSON SPACE CENTER HOUSTON, TEXAS USA 77058</p>	Released:	Revision:	Revision Date:
	06.27.2002		
	Book:	Section:	Page:
	7	7.07	2

**SURFACE MOUNT TECHNOLOGY (SMT)
GULL-WING/"L" LEADED PACKAGES(cont.)**

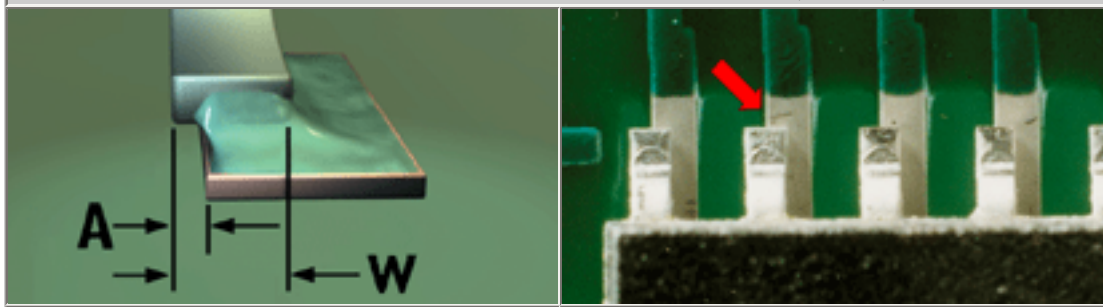

ACCEPTABLE
LATERAL/SIDE OVERHANG (A)

Lateral/side overhang shall not exceed 25% of the lead width (W), and shall not violate minimum electrical spacing requirements.

[NASA-STD-8739.2 \[8.7.4.h.\], \[12.6.2.a.4\]](#)

UNACCEPTABLE
IMPROPER LATERAL/SIDE OVERHANG

Lateral/side overhang shall not exceed 25% of the lead width (W), and shall not violate minimum electrical spacing requirements.

[NASA-STD-8739.2 \[12.9.2.b.1\]](#)

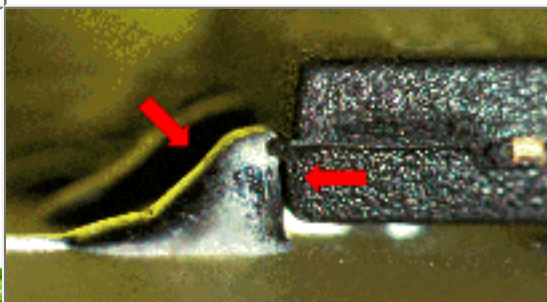
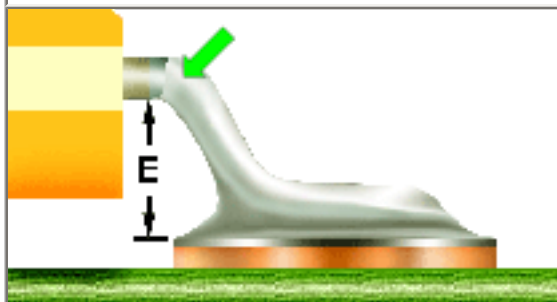

ACCEPTABLE
MAXIMUM HEEL FILLET HEIGHT (E)

Solder may extend through the stress relief bend, but must not contact the lead seal. Solder shall exhibit a concave fillet and the lead contour shall be visible.

[NASA-STD-8739.2 \[12.8.1.b\], \[12.8.2.b.16\]](#)

UNACCEPTABLE
EXCESS SOLDER

The lead contour is not discernable; the solder extends through the stress-relief bends; and, the solder contacts the component body and seal.

[NASA-STD-8739.2 \[12.8.2.b.12\], \[12.8.2.b.16\], \[12.9.2.a.2\]](#)

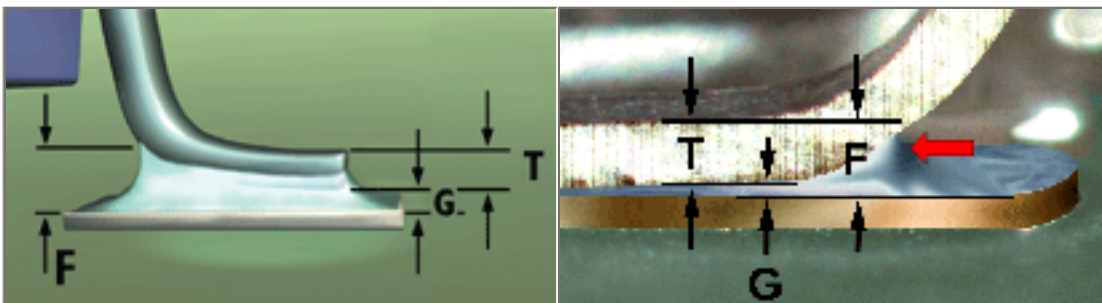

<p>ACCEPTABLE MINIMUM HEEL FILLET HEIGHT (F)</p> <p>The fillet height shall be equal to or greater than the minimum solder thickness (G), <u>plus</u> one (1) lead thickness (T).</p> <p>Best Workmanship Practice</p>	<p>UNACCEPTABLE INSUFFICIENT HEEL FILLET HEIGHT (F)</p> <p>The heel fillet height is less than the minimum solder thickness (G), <u>plus</u> one (1) lead thickness (T). This may result in a weakened solder termination.</p> <p>Best Workmanship Practice</p>
---	--

NASA WORKMANSHIP STANDARDS

 <p>NATIONAL AERONAUTICS AND SPACE ADMINISTRATION JOHNSON SPACE CENTER HOUSTON, TEXAS USA 77058</p>	Released: 06.27.2002	Revision:	Revision Date:
	Book: 7	Section: 7.07	Page: 3

**SURFACE MOUNT TECHNOLOGY (SMT)
GULL-WING/"L" LEADED PACKAGES (cont.)**

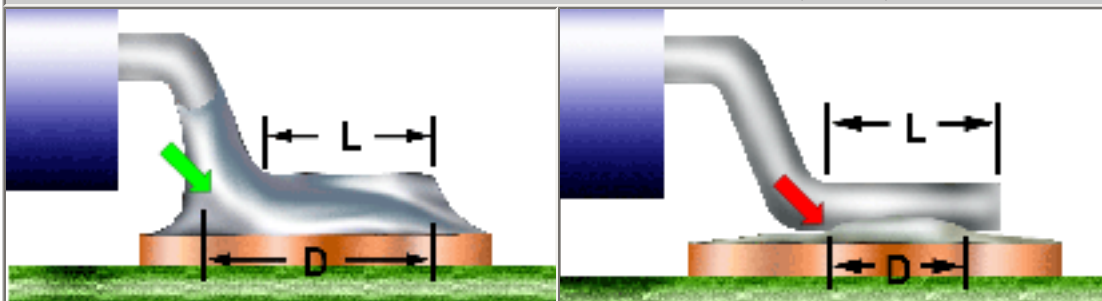

<p>ACCEPTABLE SIDE JOINT FILLET (D)</p> <p>The side joint fillet (D) shall be present, equal to the lead width (W) <u>plus</u> the heel fillet, or equal to a minimum of 75% of lead length (L) <u>plus</u> the heel fillet, whichever is less, and exhibit complete wetting and a positive contour.</p> <p>Best Workmanship Practice</p>	<p>UNACCEPTABLE SIDE JOINT FILLET (D)</p> <p>The side joint fillet shall be present, equal to the lead length (L) <u>plus</u> the heel fillet, and exhibit a positive contour.</p> <p>NASA-STD-8739.2 [12.8.1.b]</p>
--	---

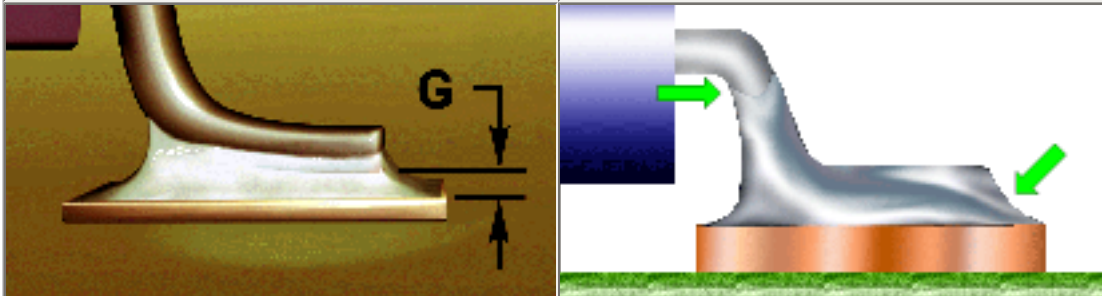

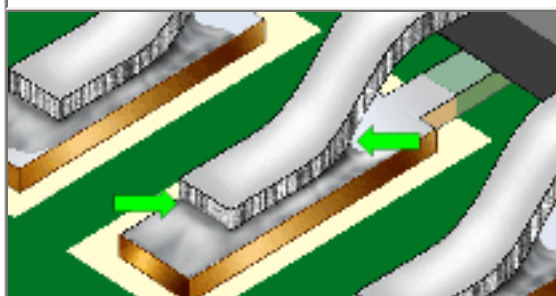
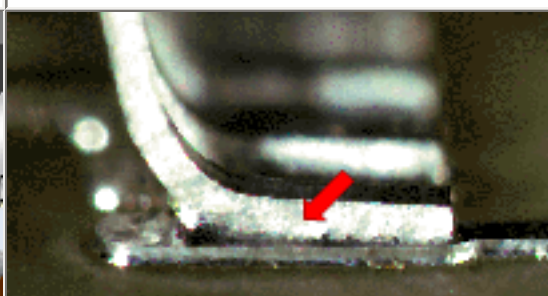
<p>PREFERRED SOLDER THICKNESS (G)</p> <p>The solder thickness shall be sufficient to form a properly wetted, concave fillet which extends over the complete periphery of the connection.</p> <p>NASA-STD-8739.2 [12.8.1.b], [12.9.2.a]</p>	<p>ACCEPTABLE MAXIMUM SOLDER</p> <p>Solder quantity is at maximum, with the fillet extending up to the lead bend and completely covering the lead. The connection exhibits a well-wetted concave fillet on all sides, and the lead contour is discernable.</p> <p>NASA-STD-8739.2 [12.8.1.b], [12.9.2.a]</p>
	
<p>ACCEPTABLE MINIMUM SOLDER (B)</p> <p>Solder quantity is minimum, but the connection is well wetted on all sides, with a concave fillet between the lead and the land. A heel fillet is evident and properly formed.</p> <p>NASA-STD-8739.2 [12.8.1.b], [12.9.2.a]</p>	<p>UNACCEPTABLE INSUFFICIENT SOLDER</p> <p>The solder quantity shall be sufficient to form a properly wetted fillet.</p> <p>NASA-STD-8739.2 [12.8.2.b.6]</p>

NASA WORKMANSHIP STANDARDS

 <p>NATIONAL AERONAUTICS AND SPACE ADMINISTRATION JOHNSON SPACE CENTER HOUSTON, TEXAS USA 77058</p>	<p>Released: 06.27.2002</p>	<p>Revision:</p>	<p>Revision Date:</p>
	<p>Book: 7</p>	<p>Section: 7.07</p>	<p>Page: 4</p>

**SURFACE MOUNT TECHNOLOGY (SMT)
GULL-WING/"L" LEADED PACKAGES (cont.)**

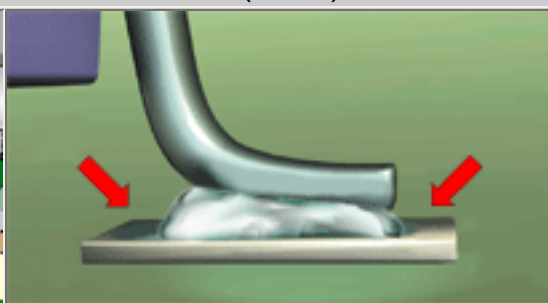
	
<p>ACCEPTABLE NONWETTING (SPECIAL EXCLUSION)</p> <p>Leads not having wettable sides (edges) by design (such as leads stamped from pre-plated stock) are not required to exhibit side fillets.</p> <p>Best Workmanship Practice</p>	<p>UNACCEPTABLE IMPROPER WETTING</p> <p>The solder fillet shall exhibit a positive wetting angle, wet all elements of the connection, and shall extend to the edge of the pad.</p> <p>NASA-STD-8739.2 [12.9.2.a.1], [12.9.2.b.4]</p>

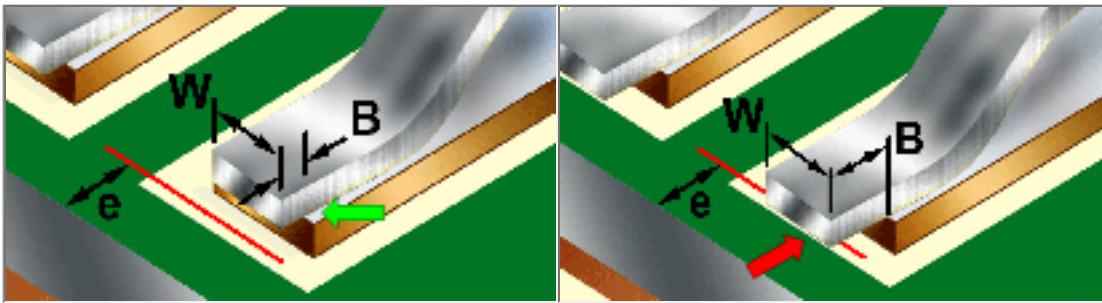

**ACCEPTABLE
TOE OVERHANG (B)**

Toe overhang (B) shall not exceed 25% of the lead width (W), and shall not violate minimum electrical spacing (e) requirements.

[NASA-STD-8739.2 \[8.7.4.h.2\], \[12.6.2.a.5\]](#)

**UNACCEPTABLE
EXCESSIVE TOE OVERHANG (B)**

Toe overhang (B) shall not exceed 25% of the lead width (W), and shall not violate minimum electrical spacing (e) requirements.

[NASA-STD-8739.2 \[12.6.2.a.4\], \[12.9.2.b.2\]](#)

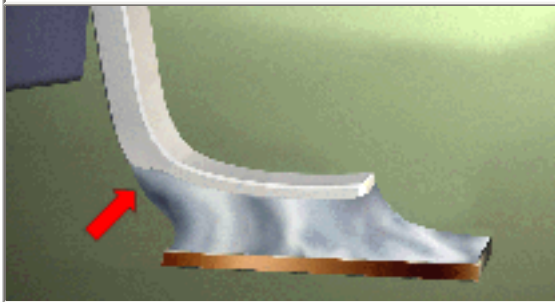

**UNACCEPTABLE
HEEL OVERHANG**

Heel overhang is prohibited.

[Best Workmanship Practice](#)

NASA WORKMANSHIP STANDARDS



**NATIONAL AERONAUTICS AND
SPACE ADMINISTRATION**
JOHNSON SPACE CENTER
HOUSTON, TEXAS USA 77058

Released:
06.27.2002

Revision:

Revision Date:

Book:
7

Section:
7.07

Page:
5



[Need a printed copy?](#)
(May take a while to load.)

Requires Adobe Reader.



[Need Adobe Reader?](#)
[Click here to download.](#)



[Questions? Suggestions?](#)

SURFACE MOUNT TECHNOLOGY (SMT)
BUTT "I" LEADED PACKAGES

BUTT "I" LEADED PACKAGES

Butt/"I" leaded parts have leads formed and positioned perpendicular to the circuit land.

The use of the Butt/"I" Leaded device termination configuration is not recommended for high reliability/spaceflight applications, due to the limited mechanical reliability of the termination.

See Section 7.01 "Surface Mount Soldering, General Requirements", for common accept/reject criteria.

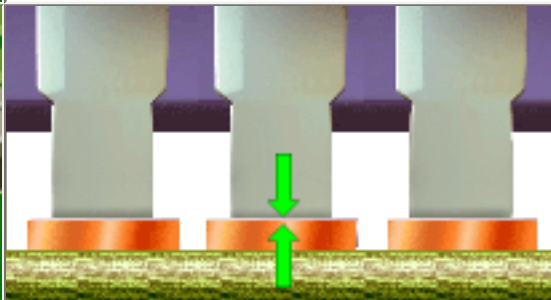
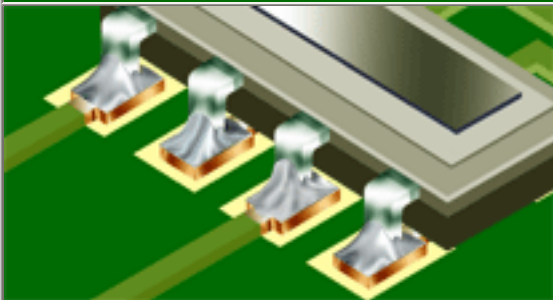
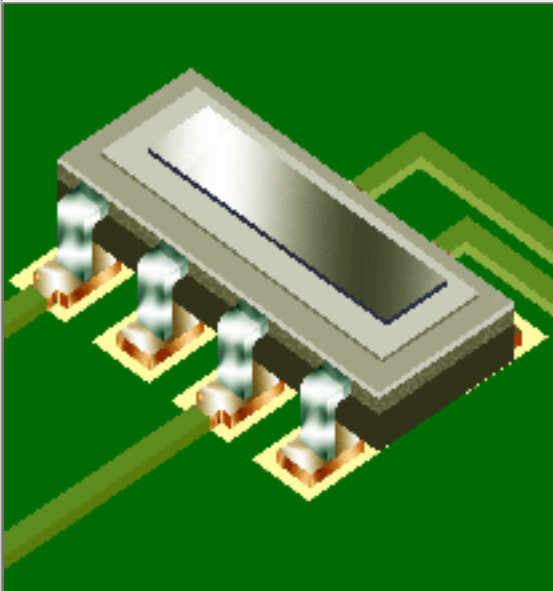

PREFERRED

The part is properly oriented to the land pattern, with each lead centered across the width of the land. Leads are planar. Fillets are shiny, concave and evident on the front and back faces of the lead.

[NASA-STD-8739.2 \[12.8.1\]](#), [\[12.9.5\]](#)

PREFERRED
COPLANARITY

The preferred planarity of the lead to the land pattern area is with the component feet parallel to, and in full contact with, the pad.

[NASA-STD-8739.2 \[7.1\]](#)

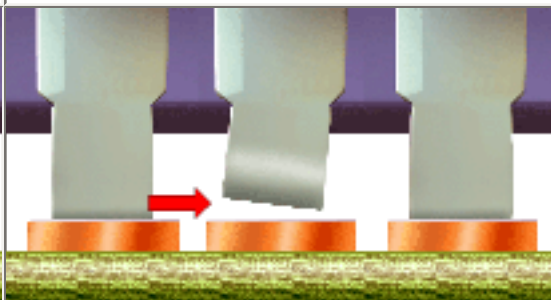
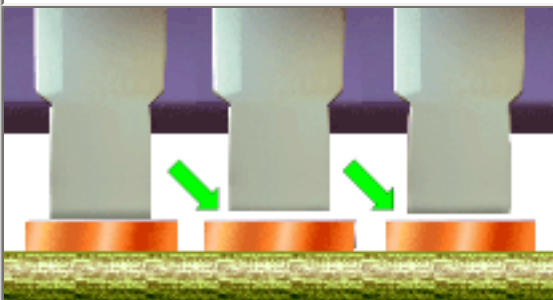

ACCEPTABLE
COPLANARITY

The maximum acceptable non-planarity between any portion of the lead foot and the pad shall not exceed 0.26 mm (0.010").

[NASA-STD-8739.2 \[7.1\]](#), [\[12.9.2.b.3\]](#)

UNACCEPTABLE
IMPROPER COPLANARITY

Excessive non-planarity results in open or mechanically weak solder joint. Improper component lead coplanarity can produce solder bridging and open terminations.

[NASA-STD-8739.2 \[7.1\]](#), [\[12.9.2.b.3\]](#)

NASA WORKMANSHIP STANDARDS





NATIONAL AERONAUTICS AND
SPACE ADMINISTRATION
JOHNSON SPACE CENTER
HOUSTON, TEXAS USA 77058

Released:
06.27.2002

Revision:

Revision Date:

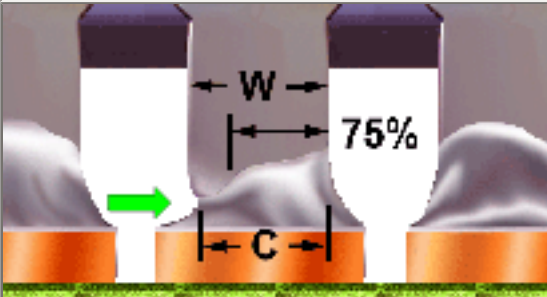
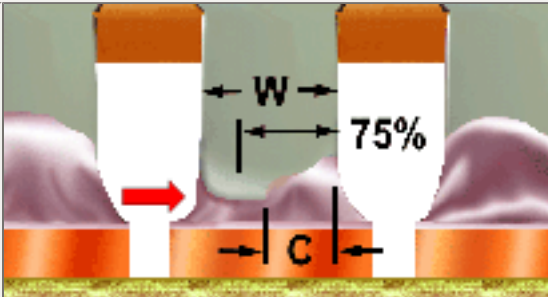
	Book: 7	Section: 7.08	Page: 1
--	------------	------------------	------------

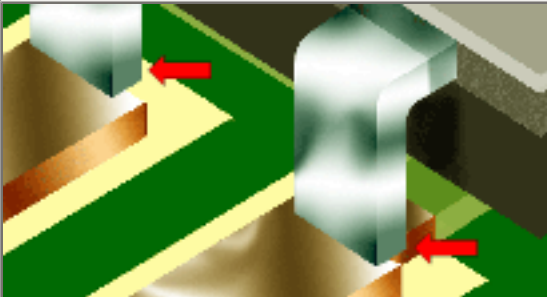
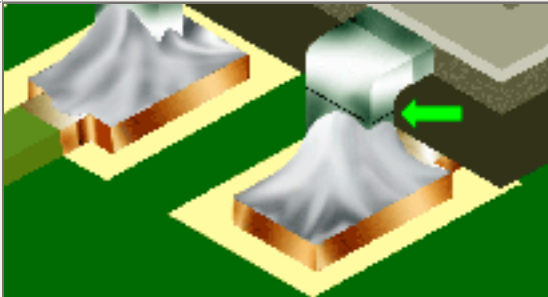
SURFACE MOUNT TECHNOLOGY GULL-WING/BUTT "I" LEADED PACKAGES (cont.)	
	
<p>ACCEPTABLE END JOINT WIDTH (C)</p> <p>The width of the end joint (C) should be greater than the lead width (W), but shall not be less than 75% of lead width (W).</p> <p>Best Workmanship Practice</p>	<p>UNACCEPTABLE INSUFFICIENT END JOINT WIDTH (C)</p> <p>The width of the end joint is less than 75% of the lead width (W).</p> <p>Best Workmanship Practice</p>
	
<p>MANDATORY HEEL FILLET</p> <p>There shall be evidence of complete wetting and a positive wetting angle. The heel fillet shall extend across the entire width of the contact area.</p> <p>NASA-STD-8739.2 [12.9.5.b.2]</p>	<p>UNACCEPTABLE MISSING HEEL FILLET</p> <p>There shall be evidence of complete wetting and a positive wetting angle.</p> <p>NASA-STD-8739.2 [12.9.2.b.2]</p>
	

<p>MANDATORY HEEL OVERHANG</p> <p>Heel overhang is prohibited, as it will prevent the formation of the heel fillet (mandatory). NASA-STD-8739.2 [8.8.4], [12.9.5]</p>	<p>ACCEPTABLE HEEL/TOE FILLET HEIGHT</p> <p>The fillet height shall not exceed 75% of the lead height. The fillet shall be the full width of the contact area, exhibit a positive wetting angle, and the lead contour shall be visible. NASA-STD-8739.2 [12.9.5.a], [12.9.5.b.3]</p>
--	---

NASA WORKMANSHIP STANDARDS			
 <p>NATIONAL AERONAUTICS AND SPACE ADMINISTRATION JOHNSON SPACE CENTER HOUSTON, TEXAS USA 77058</p>	Released:	Revision:	Revision Date:
	06.27.2002		
	Book:	Section:	Page:
	7	7.08	2

**SURFACE MOUNT TECHNOLOGY (SMT)
BUTT "I" LEADED PACKAGES (cont.)**

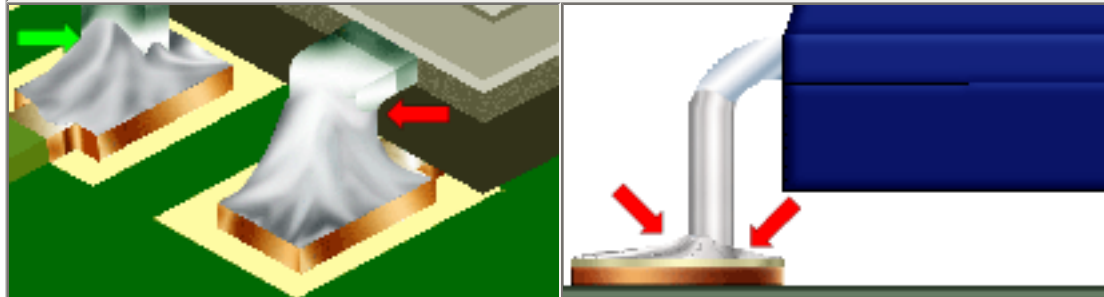

<p>UNACCEPTABLE EXCESSIVE HEEL/TOE FILLET HEIGHT</p> <p>The fillet height shall not exceed 75% of the lead height. The fillet shall be the full width of the contact area, exhibit a positive wetting angle, and the lead contour shall be visible. NASA-STD-8739.2 [12.9.5.b.3]</p>	<p>UNACCEPTABLE INSUFFICIENT HEEL/TOE FILLET HEIGHT</p> <p>The fillet height shall be sufficient to exhibit evidence of complete wetting. NASA-STD-8739.2 [12.9.5.a.1]</p>
---	---

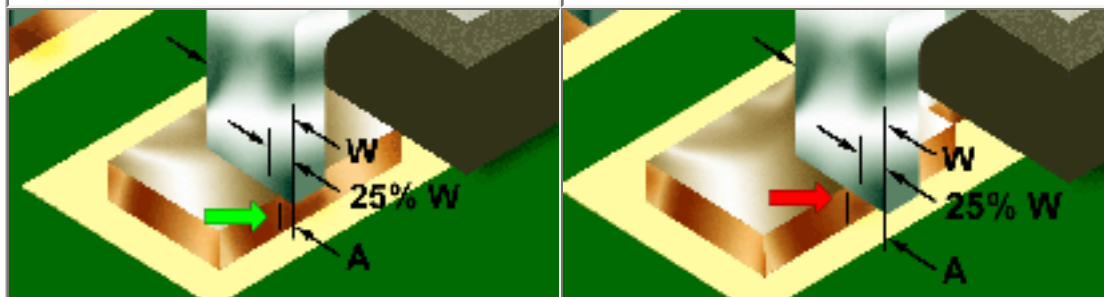

<p>ACCEPTABLE LATERAL/SIDE OVERHANG (A)</p> <p>Lateral/side overhang shall not exceed 25% of lead width. NASA-STD-8739.2 [8.7.4.k]</p>	<p>UNACCEPTABLE IMPROPER LATERAL/SIDE OVERHANG</p> <p>The lead is overhanging the termination pad in excess of 25% of the lead width. NASA-STD-8739.2 [12.6.2.a.7], [12.9.5.b.1]</p>
---	---

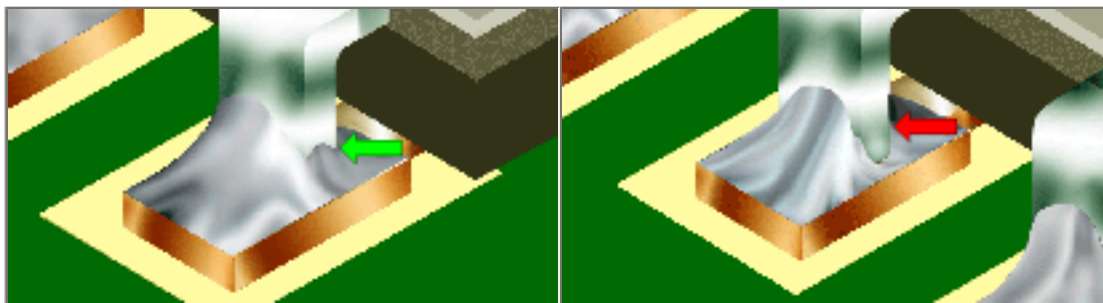

**PREFERRED
SIDE JOINT FILLET***

The side joint fillet shall exhibit proper wetting to the component lead, a positive contour, and shall extend to the edges of the termination pad. (*See Nonwetting for special exclusion.)

[NASA-STD-8739.2 \[12.8.1.b\]](#), [\[12.9.5.a.1\]](#)

UNACCEPTABLE

INSUFFICIENT SIDE JOINT FILLET (D)*

The side joint fillet does not exhibit proper wetting, or a positive contour. (*See Nonwetting for exclusion.)

[NASA-STD-8739.2 \[12.8.2.b.4\]](#)

NASA WORKMANSHIP STANDARDS



**NATIONAL AERONAUTICS AND
SPACE ADMINISTRATION**
JOHNSON SPACE CENTER
HOUSTON, TEXAS USA 77058

Released:
06.27.2002

Revision:

Revision Date:

Book:
7

Section:
7.07

Page:
3

**SURFACE MOUNT TECHNOLOGY (SMT)
BUTT "I" LEADED PACKAGES (cont.)**

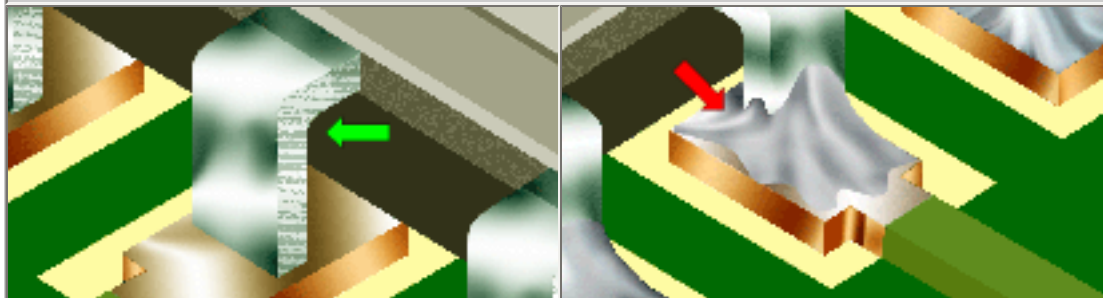

**ACCEPTABLE
NONWETTING
(SPECIAL EXCLUSION)**

Leads not having wettable sides (edges) by design (such as leads stamped from pre-plated stock) are not required to exhibit side fillets.

[Best Workmanship Practice](#)

**UNACCEPTABLE
IMPROPER WETTING**

The solder fillet shall exhibit a positive wetting angle, wet all elements of the connection with smooth flow lines, and shall extend to the edge of the pad.

[NASA-STD-8739.2 \[12.9.5.a.1\]](#), [\[12.9.5.b.4\]](#)

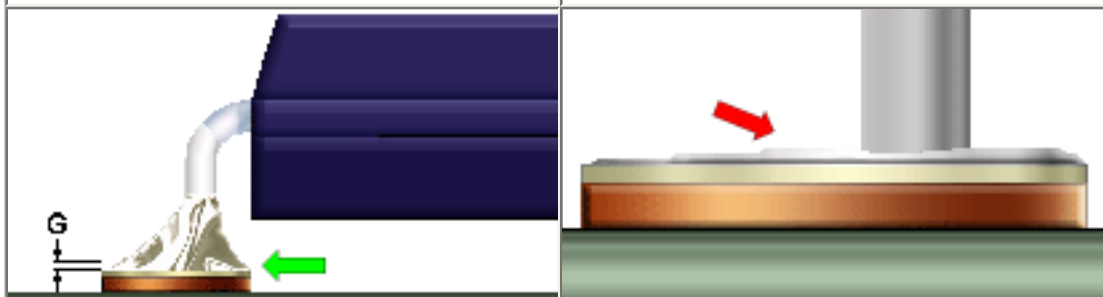

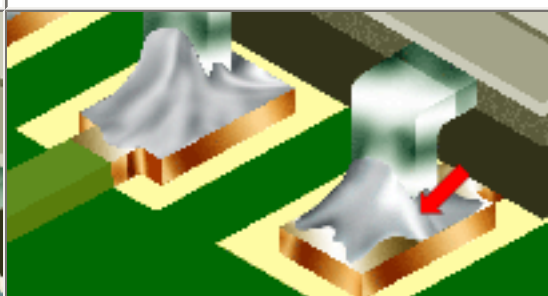

<p>PREFERRED SOLDER THICKNESS (G)</p> <p>The solder thickness shall be sufficient to form a properly wetted, concave fillet which extends over the complete periphery of the connection.</p> <p>NASA-STD-8739.2 [12.8.1.b], [12.9.5.a]</p>	<p>UNACCEPTABLE INSUFFICIENT SOLDER QUANTITY</p> <p>The solder quantity shall be sufficient to form a properly wetted, concave fillet.</p> <p>NASA-STD-8739.2 [12.9.5.a.1], [12.9.5.b.4]</p>
	
<p>UNACCEPTABLE EXCESS SOLDER</p> <p>The solder fillet may be convex, but shall exhibit a positive wetting angle, and the lead contour shall be visible.</p> <p>NASA-STD-8739.2 [12.9.5.a.2]</p>	<p>UNACCEPTABLE INCOMPLETE SOLDER FILLET</p> <p>The solder fillet shall exhibit complete wetting and extend over the complete periphery of the connection.</p> <p>NASA-STD-8739.2 [12.9.5.b.4]</p>

NASA WORKMANSHIP STANDARDS

 <p>NATIONAL AERONAUTICS AND SPACE ADMINISTRATION JOHNSON SPACE CENTER HOUSTON, TEXAS USA 77058</p>	<p>Released: 06.27.2002</p>	<p>Revision:</p>	<p>Revision Date:</p>
	<p>Book: 7</p>	<p>Section: 7.08</p>	<p>Page: 4</p>

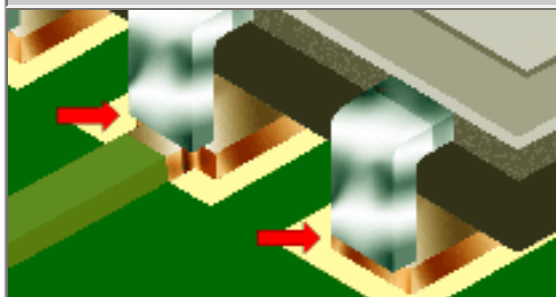
**SURFACE MOUNT TECHNOLOGY (SMT)
BUTT "I" LEADED PACKAGES (cont.)**

	
<p>MANDATORY TOE OVERHANG</p> <p>Toe overhang is prohibited.</p> <p>NASA-STD-8739.2 [8.8.4], [12.9.5]</p>	<p>PREFERRED TOE FILLET</p> <p>There shall be evidence of complete wetting and a positive wetting angle.</p> <p>NASA-STD-8739.2 [12.9.5.a.1]</p>

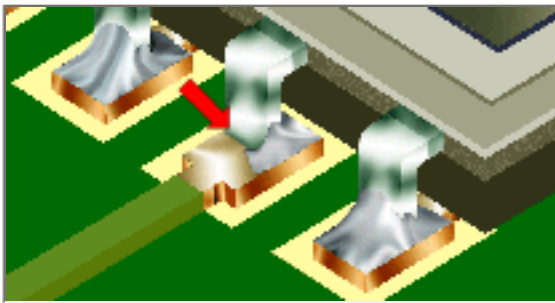

UNACCEPTABLE
MISSING TOE FILLET

There shall be evidence of complete wetting and a positive wetting angle that extends over the complete periphery of the connection.

[NASA-STD-8739.2 \[12.8.1.b\], \[12.9.5\]](#)

NASA WORKMANSHIP STANDARDS			
 <p>NATIONAL AERONAUTICS AND SPACE ADMINISTRATION JOHNSON SPACE CENTER HOUSTON, TEXAS USA 77058</p>	Released: 06.27.2002	Revision:	Revision Date:
	Book: 7	Section: 7.08	Page: 5



[Need a printed copy?](#)
(May take a while to load.)
Requires Adobe Reader.



[Need Adobe Reader?](#)
[Click here to download.](#)



[Questions? Suggestions?](#)

SURFACE MOUNT TECHNOLOGY (SMT)
"J" LEADED PACKAGES

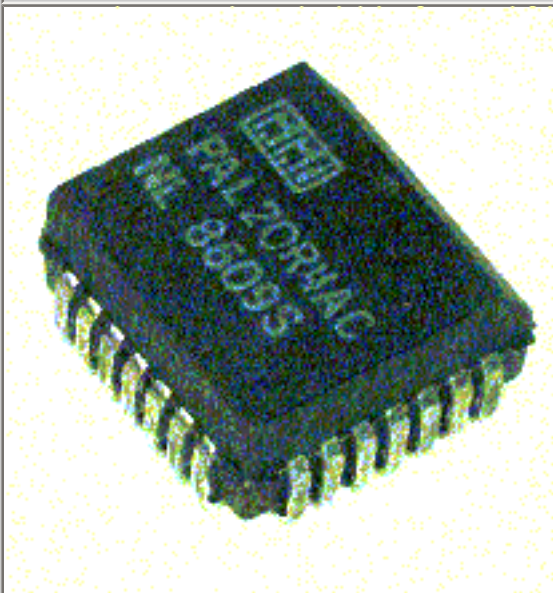

"J" LEADED PACKAGES

"J" Lead Packages have termination leads that are formed into a J pattern, with the lead's tail folding up and under the package body (instead of flat and outwards like a "Gull-wing"). "J" lead terminations are considered to be the second most reliable termination style of the leaded SMT devices.

See Section 7.01 "Surface Mount Soldering, General Requirements", for common accept/reject criteria.

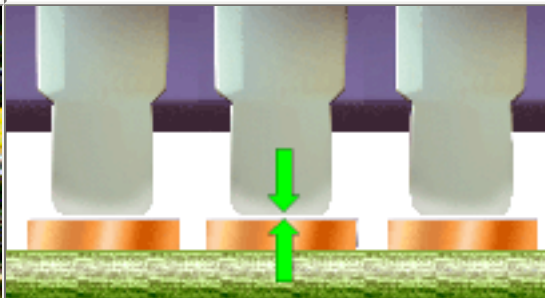
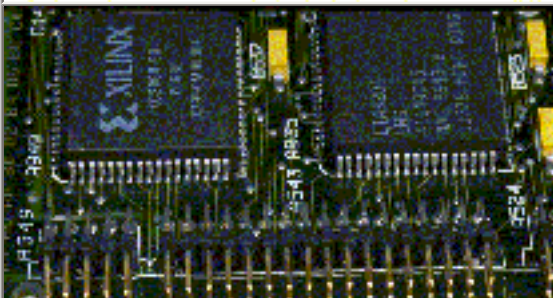

PREFERRED

The parts are properly oriented to the land patterns, with each lead centered across the width of the land. Leads are planar, fillets are shiny and concave and a heel fillet is evident.

[NASA-STD-8739.2 \[7.1\]](#), [\[12.8.1\]](#), [\[12.9.3.a\]](#)

PREFERRED
COPLANARITY

The lead's foot should be parallel to, and in full contact with, the termination pad.

[NASA-STD-8739.2 \[7.1\]](#)

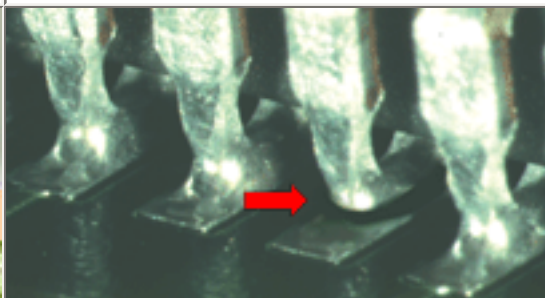
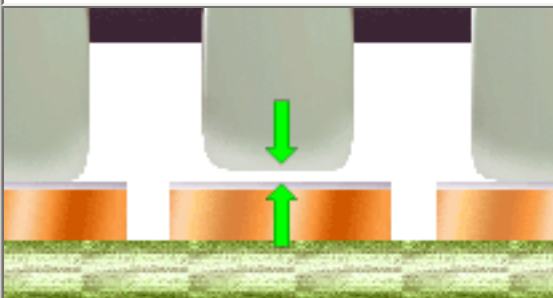

ACCEPTABLE
COPLANARITY

The maximum acceptable variation in planarity between any portion of the lead foot and the pad shall not exceed 0.26 mm (0.010").

[NASA-STD-8739.2 \[7.1\]](#), [\[12.8.1.h\]](#)

UNACCEPTABLE
IMPROPER COPLANARITY

Excessive non-planarity may result in open or mechanically weak solder terminations, excessive part tilt, solder contact with the component body, or violate minimum electrical spacing requirements.

[NASA-STD-8739.2 \[12.8.2.a.10\]](#)

NASA WORKMANSHIP STANDARDS



NATIONAL AERONAUTICS AND
SPACE ADMINISTRATION
JOHNSON SPACE CENTER
HOUSTON, TEXAS USA 77058

Released:
06.27.2002

Revision:

Revision Date:

	Book: 7	Section: 7.09	Page: 1
--	------------	------------------	------------

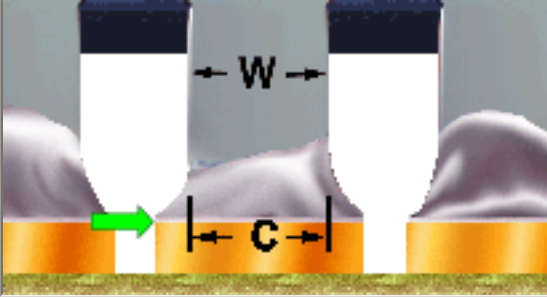
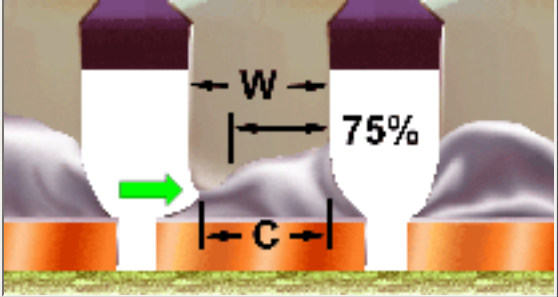
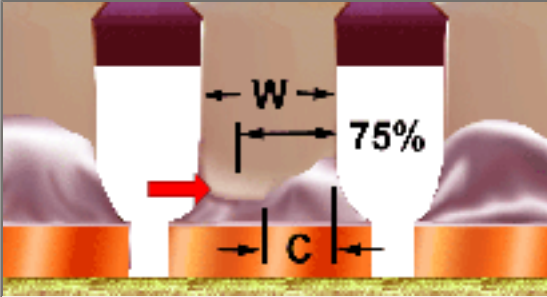
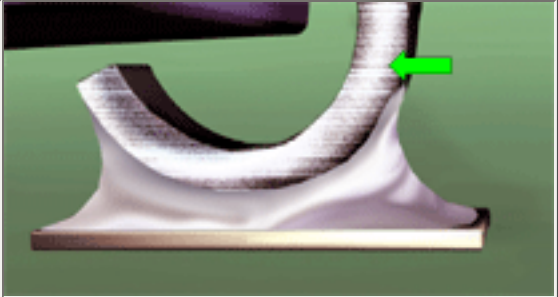
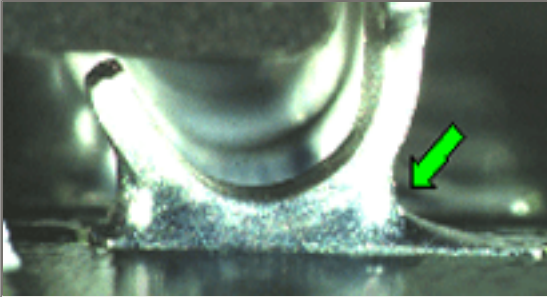
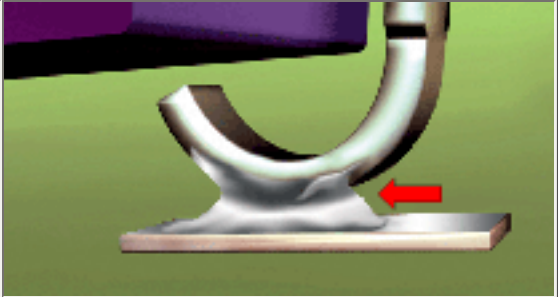
SURFACE MOUNT TECHNOLOGY GULL-WING/"J" LEADED PACKAGES (cont.)	
	
<p>PREFERRED END JOINT WIDTH (C)</p> <p>The width of the end joint (C) should be greater than or equal to the lead width (W).</p> <p>Best Workmanship Practice</p>	<p>ACCEPTABLE END JOINT WIDTH (C)</p> <p>The width of the end joint (C) shall be greater than or equal to 75% of the lead width (W).</p> <p>Best Workmanship Practice</p>
	
<p>UNACCEPTABLE INSUFFICIENT END JOINT WIDTH (C)</p> <p>The width of the end joint is less than 75% of the lead width.</p> <p>Best Workmanship Practice</p>	<p>ACCEPTABLE NONWETTING (SPECIAL EXCLUSION)</p> <p>Leads not having wettable sides (edges) by design (such as leads stamped from pre-plated stock) are not required to exhibit side fillets.</p> <p>Best Workmanship Practice</p>
	

<p>MANDATORY HEEL FILLET</p> <p>A heel fillet is mandatory and the contour shall be positive. NASA-STD-8739.2 [12.9.3.a.1]</p>	<p>UNACCEPTABLE MISSING HEEL FILLET</p> <p>A heel fillet is mandatory and the contour shall be positive. NASA-STD-8739.2 [12.9.3.a.1], [12.9.3.b.6]</p>
---	--

NASA WORKMANSHIP STANDARDS

 <p>NATIONAL AERONAUTICS AND SPACE ADMINISTRATION JOHNSON SPACE CENTER HOUSTON, TEXAS USA 77058</p>	Released: 06.27.2002	Revision:	Revision Date:
	Book: 7	Section: 7.09	Page: 2

**SURFACE MOUNT TECHNOLOGY (SMT)
"J" LEADED PACKAGES (cont.)**

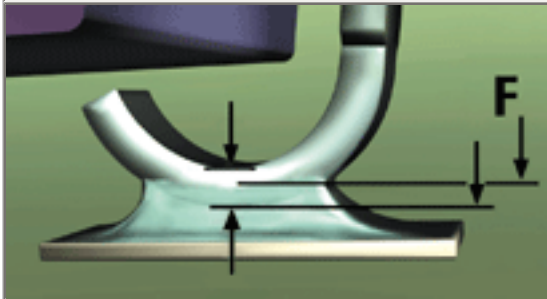

**ACCEPTABLE
HEEL FILLET HEIGHT (F)**

The fillet height shall not exceed 50% of the lead height. The fillet may be convex, but shall exhibit a positive wetting angle, and the lead contour shall be visible.
[NASA-STD-8739.2 \[12.9.3\]](#)

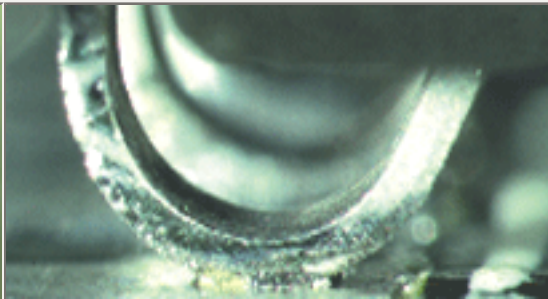

**UNACCEPTABLE
INSUFFICIENT HEEL FILLET HEIGHT**

The fillet height shall be equal to or greater than the minimum solder thickness, plus one (1) lead thickness (t).
[NASA-STD-8739.2 \[12.9.3.b.3\], \[12.9.3.b.6\]](#)



**PREFERRED
LATERAL/SIDE OVERHANG (A)**

There should be no lateral/side overhang, the component lead should be centered on the land.
[NASA-STD-8739.2 \[12.6.2.a.5\]](#)

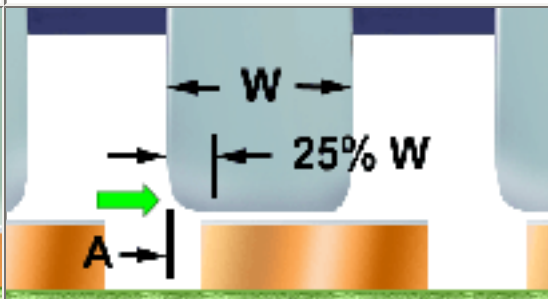

**ACCEPTABLE
LATERAL/SIDE OVERHANG (A)**

Lateral/Side overhang (A) shall not exceed 25% of the lead width (W), and shall not violate minimum electrical spacing requirements.
[NASA-STD-8739.2 \[12.6.2.a.5\]](#)

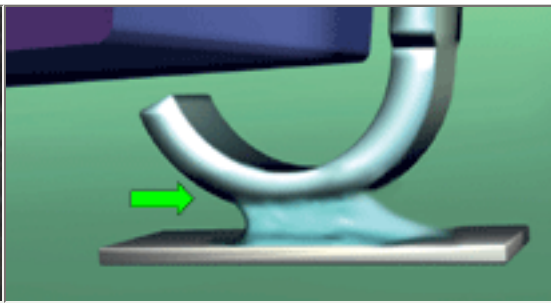
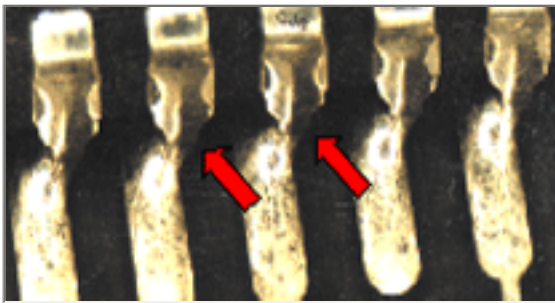

UNACCEPTABLE
IMPROPER LATERAL/SIDE OVERHANG
 Lateral/Side overhang shall not exceed 25% of the lead width (W), and shall not violate minimum electrical spacing requirements.
[NASA-STD-8739.2 \[12.6.2.a.5\], \[12.9.3.b.1\]](#)

ACCEPTABLE
MISSING TOE FILLET
 A toe fillet is not required. However, the termination shall exhibit complete wetting and a positive wetting angle between the lead and termination pad.
[Best Workmanship Practice](#)

NASA WORKMANSHIP STANDARDS			
 NATIONAL AERONAUTICS AND SPACE ADMINISTRATION JOHNSON SPACE CENTER HOUSTON, TEXAS USA 77058	Released: 06.27.2002	Revision:	Revision Date:
	Book: 7	Section: 7.09	Page: 3

SURFACE MOUNT TECHNOLOGY (SMT)
 "J" LEADED PACKAGES (cont.)

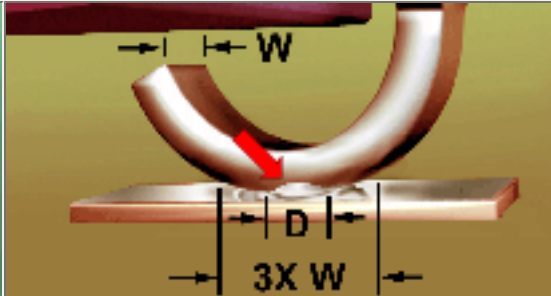
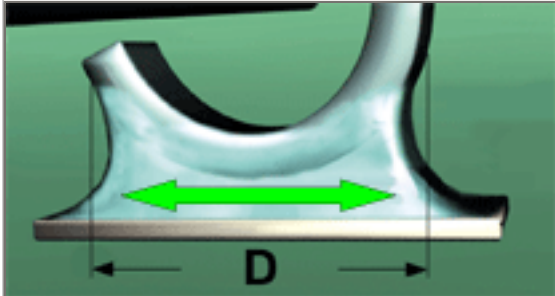

PREFERRED
SIDE JOINT FILLET (D)*
 The side joint fillet shall be three times (3X) the lead width (W), and shall exhibit a positive contour. (* See Nonwetting for exclusion.)
[Best Workmanship Practice](#)

UNACCEPTABLE
INSUFFICIENT SIDE JOINT FILLET (D)
 The side joint fillet (D) shall be three times (3X) the lead width (W), and shall exhibit a positive contour.
[Best Workmanship Practice](#)

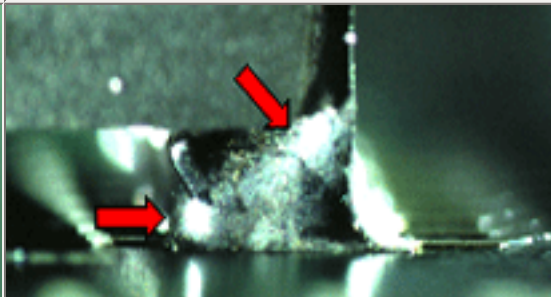
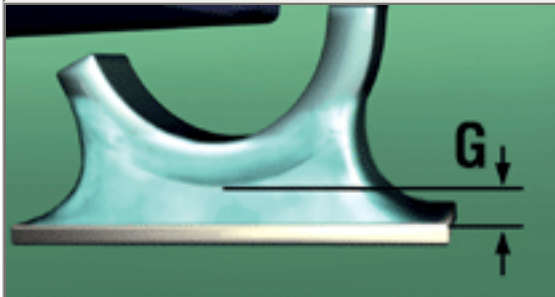

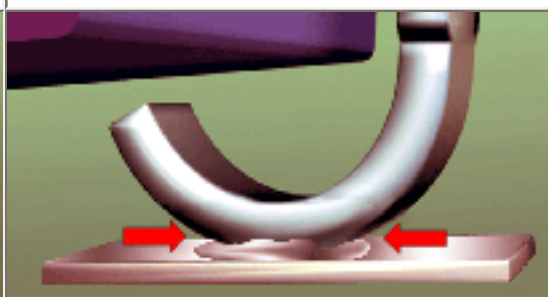
<p>PREFERRED SOLDER THICKNESS (G)</p> <p>The solder thickness shall be sufficient to form a properly wetted fillet.</p> <p>Best Workmanship Practice</p>	<p>UNACCEPTABLE EXCESS SOLDER</p> <p>The solder fillet may be convex, but shall exhibit a positive wetting angle, the lead contour shall be visible, and the solder shall not contact the component body.</p> <p>NASA-STD-8739.2 [12.8.1.c], [12.9.3.b.4]</p>
	
<p>UNACCEPTABLE INCOMPLETE SOLDER FILLET</p> <p>The solder fillet shall extend to the land edge.</p> <p>NASA-STD-8739.2 [12.8.1.b]</p>	<p>UNACCEPTABLE INSUFFICIENT SOLDER QUANTITY</p> <p>The solder quantity shall be sufficient to form a properly wetted fillet.</p> <p>NASA-STD-8739.2 [12.9.3.b.3]</p>

NASA WORKMANSHIP STANDARDS			
 <p>NATIONAL AERONAUTICS AND SPACE ADMINISTRATION JOHNSON SPACE CENTER HOUSTON, TEXAS USA 77058</p>	Released: 06.27.2002	Revision:	Revision Date:
	Book: 7	Section: 7.09	Page: 4

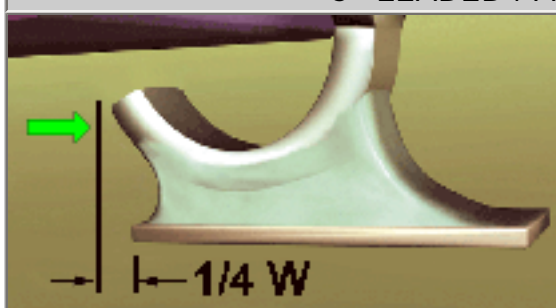
SURFACE MOUNT TECHNOLOGY (SMT) "J" LEADED PACKAGES (cont.)	
	
<p>ACCEPTABLE TOE OVERHANG</p> <p>Toe overhang shall not exceed 25% of the lead width (W), and shall not violate minimum electrical spacing requirements.</p> <p>NASA-STD-8739.2 [12.6.2.a.5]</p>	<p>UNACCEPTABLE EXCESSIVE TOE OVERHANG</p> <p>Toe overhang shall not exceed 25% of the lead width (W), and shall not violate minimum electrical spacing requirements.</p> <p>NASA-STD-8739.2 [12.6.2.a.5], [12.9.3.b.2]</p>

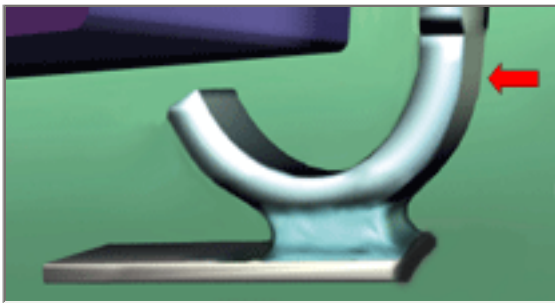

**UNACCEPTABLE
HEEL OVERHANG**

Heel overhang is prohibited, as this condition routinely results in toe overhang (on the opposite side of the device), and may prevent the proper formation of a heel fillet.

[Best Workmanship Practice](#)

NASA WORKMANSHIP STANDARDS



**NATIONAL AERONAUTICS AND
SPACE ADMINISTRATION**
JOHNSON SPACE CENTER
HOUSTON, TEXAS USA 77058

Released:
06.27.2002

Revision:

Revision Date:

Book:
7

Section:
7.09

Page:
5



[Need a printed copy?](#)
(May take a while to load.)
Requires Adobe Reader.



[Need Adobe Reader?](#)
[Click here to download.](#)



[Questions? Suggestions?](#)

**SURFACE MOUNT TECHNOLOGY (SMT)
INWARD-FORMED "L" LEAD PACKAGES**

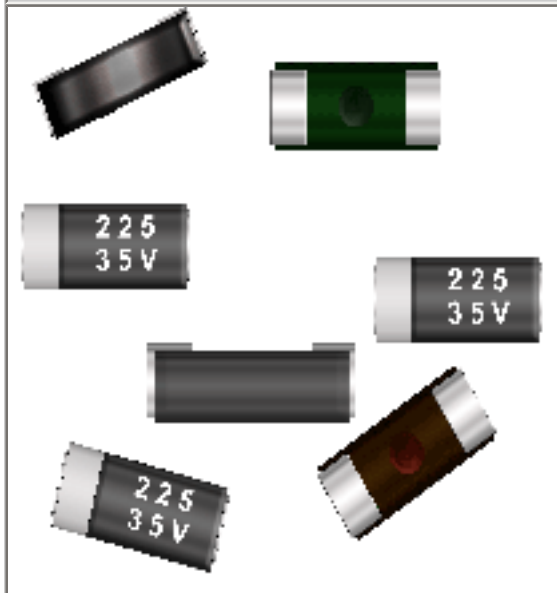

INWARD-FORMED "L" LEAD PACKAGES

Inward-formed "L" lead packages have leads that are formed in a configuration very similar to the outline of the letter "L", with the lead bent underneath the component package.

The "L" lead configuration is a shortened (both length and height) version of the "Gull-Wing" and the leads tend to be much stiffer, reducing coplanarity/planarity problems and offering a smaller "footprint". See Section 7.01 "Surface Mount Soldering, General Requirements", for common accept/reject criteria.

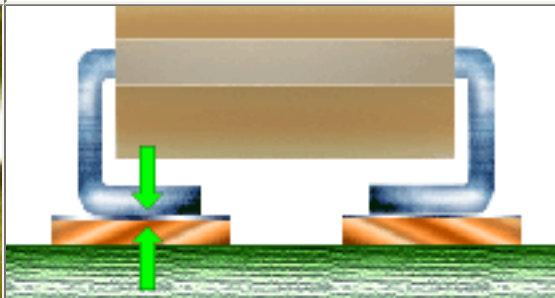
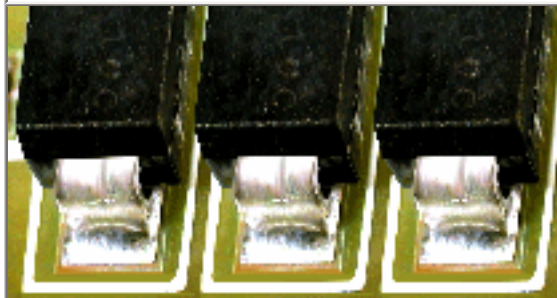

PREFERRED

The parts are properly oriented to the land pattern, with each lead centered across the width of the land. Leads are planar and fully wetted, fillets are shiny and concave, and heel fillet is evident.

[NASA-STD-8739.2 \[8.7.4\]](#), [\[12.6.2\]](#), [\[12.8\]](#), [\[12.9.4\]](#)

**PREFERRED
COPLANARITY**

The lead's foot should be parallel to, and in full contact with the termination pad.

[NASA-STD-8739.2 \[7.1\]](#)

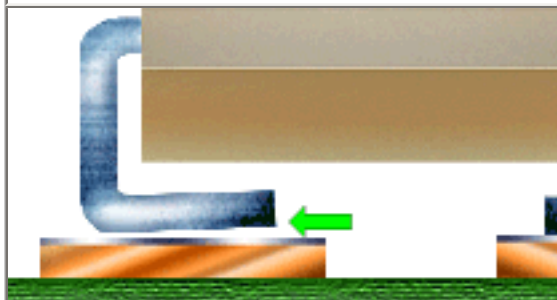

**ACCEPTABLE
COPLANARITY**

The maximum acceptable variation in planarity between any portion of the lead foot and the termination pad shall not exceed 0.26 mm (0.010").

[NASA-STD-8739.2 \[7.1\]](#), [\[12.8.1.h\]](#)

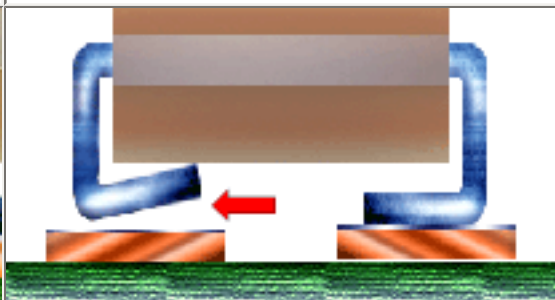

**UNACCEPTABLE
IMPROPER COPLANARITY**

Excessive non-planarity may result in open or mechanically weak solder terminations, excessive part tilt, solder contact with the component body, or violate minimum electrical spacing requirements.

[NASA-STD-8739.2 \[12.8.2.a.10\]](#)

NASA WORKMANSHIP STANDARDS





**NATIONAL AERONAUTICS AND SPACE ADMINISTRATION
JOHNSON SPACE CENTER
HOUSTON, TEXAS USA 77058**

Released:
06.27.2002

Revision:

Revision Date:

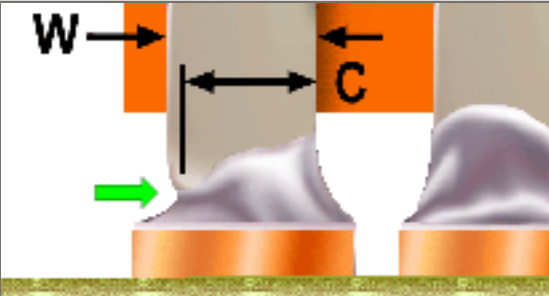
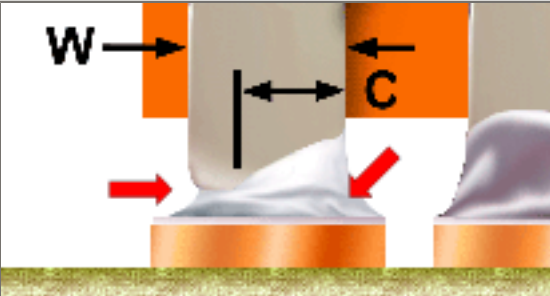
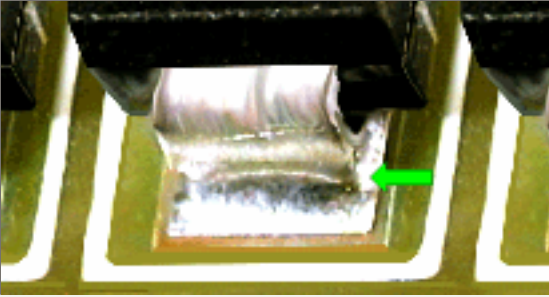
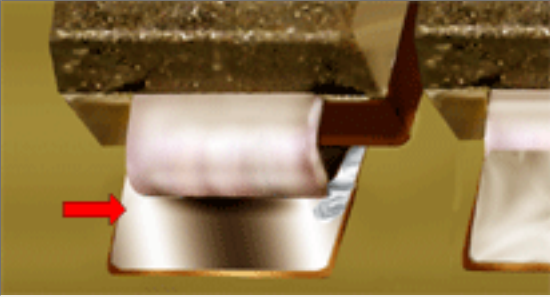
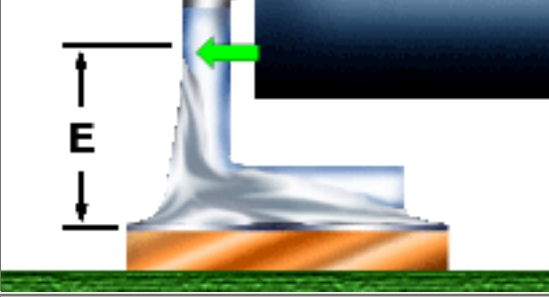
	Book: 7	Section: 7.10	Page: 1
--	------------	------------------	------------

SURFACE MOUNT TECHNOLOGY GULL-WING/INWARD-FORMED "L" LEAD PACKAGES (cont.)	
	
<p>ACCEPTABLE END JOINT WIDTH (C)</p> <p>The width of the end joint (C) shall be greater than or equal to 75% the lead width (W). Best Workmanship Practice</p>	<p>UNACCEPTABLE INSUFFICIENT END JOINT WIDTH (C)</p> <p>The width of the end joint is less than 75% of the lead width (W). This can result in a mechanically weak solder termination. Best Workmanship Practice</p>
	
<p>MANDATORY HEEL FILLET</p> <p>A heel fillet is mandatory and the contour shall be positive. NASA-STD-8739.2 [12.8.1], [12.9.4]</p>	<p>UNACCEPTABLE MISSING HEEL FILLET</p> <p>A heel fillet is mandatory. A missing heel fillet is an indicator of improper process control (i.e. improper positioning or solderability, insufficient solder quantity, etc.). NASA-STD-8739.2 [12.9.4.b.2]</p>
	
<p>ACCEPTABLE MAXIMUM HEEL FILLET HEIGHT (E)</p> <p>Solder may extend upwards a maximum of 75% of the lead height. Solder shall not contact the component body on the inside of the lead bend, shall exhibit a concave fillet and the lead contour shall be discernable. NASA-STD-8739.2 [12.8.1], [12.9.4.a]</p>	<p>UNACCEPTABLE EXCESSIVE HEEL FILLET HEIGHT (F)</p> <p>The heel fillet extends to the top of the lead and exhibits a convex profile. NASA-STD-8739.2 [12.8.2.b.12], [12.9.4.b.3]</p>

NASA WORKMANSHIP STANDARDS			
 <p>NATIONAL AERONAUTICS AND SPACE ADMINISTRATION JOHNSON SPACE CENTER HOUSTON, TEXAS USA 77058</p>	Released: 06.27.2002	Revision:	Revision Date:
	Book: 7	Section: 7.10	Page: 2

SURFACE MOUNT TECHNOLOGY (SMT)
INWARD-FORMED "L" LEAD PACKAGES (cont.)

	
<p>ACCEPTABLE MINIMUM HEEL FILLET HEIGHT (F)</p> <p>The termination does not exhibit a fully wetted, concave heel fillet.</p> <p>NASA-STD-8739.2 [12.9.4]</p>	<p>UNACCEPTABLE INSUFFICIENT HEEL FILLET HEIGHT</p> <p>The termination does not exhibit a fully wetted, concave heel fillet.</p> <p>NASA-STD-8739.2 [12.9.4]</p>
	
<p>PREFERRED LATERAL/SIDE OVERHANG (A)</p> <p>The target condition is no lateral/side overhang (A), with the component leads centered on the termination lands/pads.</p> <p>NASA-STD-8739.2 [8.7.4.j], [12.6.2], [12.8.1.h]</p>	<p>ACCEPTABLE LATERAL/SIDE OVERHANG (A)</p> <p>The component lead is overhanging the termination pad by less than 25% of the lead width (W), and the overhang condition does not violate minimum electrical spacing requirements.</p> <p>NASA-STD-8739.2 [12.6.2.a.6], [12.9.4]</p>
	

<p>UNACCEPTABLE</p> <p>IMPROPER LATERAL/SIDE OVERHANG (A)</p> <p>Lateral/Side overhang shall not exceed 25% of the lead width (W), and shall not violate minimum electrical spacing requirements.</p> <p>NASA-STD-8739.2 [12.9.4.b.1]</p>	<p>PREFERRED</p> <p>SOLDER THICKNESS (G)</p> <p>The solder thickness shall be sufficient to form a properly wetted, concave fillet which extends over the complete periphery of the connection.</p> <p>NASA-STD-8739.2 [12.8.1.b], [12.9.4.a]</p>
--	--

NASA WORKMANSHIP STANDARDS			
 <p>NATIONAL AERONAUTICS AND SPACE ADMINISTRATION</p> <p>JOHNSON SPACE CENTER HOUSTON, TEXAS USA 77058</p>	Released:	Revision:	Revision Date:
	06.27.2002		
	Book:	Section:	Page:
	7	7.10	3

**SURFACE MOUNT TECHNOLOGY (SMT)
INWARD-FORMED "L" LEAD PACKAGES (cont.)**

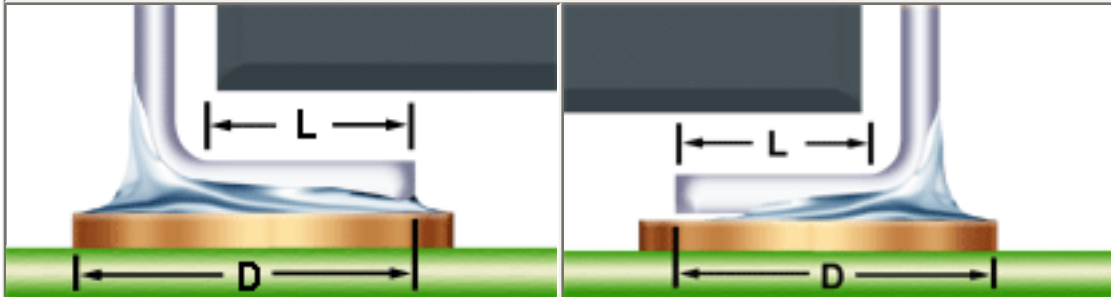

ACCEPTABLE
SIDE JOINT FILLET (D)

The side joint fillet shall be present, equal to the lead length (L) plus the heel fillet, and exhibit a positive contour.

[Best Workmanship Practice](#)

UNACCEPTABLE
IMPROPER SIDE JOINT FILLET (D)

A side joint fillet less than 75% of the lead length (L) plus the heel fillet, or that exhibits flow lines is an indicator of a process problem.

[Best Workmanship Practice](#)

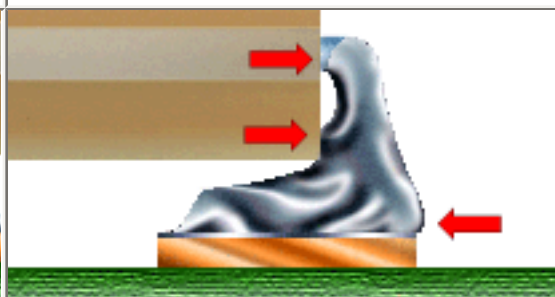
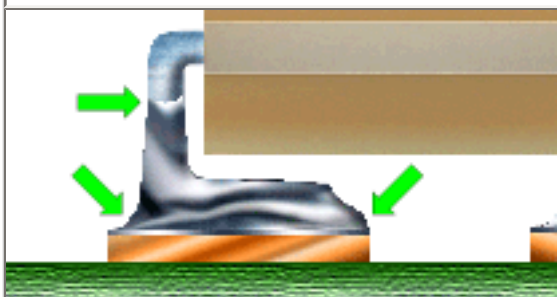

ACCEPTABLE
MAXIMUM SOLDER

Solder quantity is at maximum, but does not contact the component body, or extend into the upper lead bend. The connection is well wetted, with a concave fillet between the lead and the land, and the lead contour is visible.

[NASA-STD-8739.2 \[12.8.1\], \[12.9.4.a\]](#)

UNACCEPTABLE
EXCESS SOLDER

Solder has contacted the component body on the inside of the lead bend, extending beyond 75% of the lead height into the upper lead bend, and exhibits a convex fillet.

[NASA-STD-8739.2 \[12.8.2.b.16\], \[12.9.4.b.3\]](#)

<p style="text-align: center;">ACCEPTABLE MINIMUM SOLDER</p> <p>Solder quantity is minimum, with a concave heel fillet evident. The solder has completely wetted all elements of the termination, and extends to the periphery of the termination pads.</p> <p>NASA-STD-8739.2 [12.8.1.b], [12.9.4.a.1]</p>	<p style="text-align: center;">UNACCEPTABLE INSUFFICIENT SOLDER</p> <p>The solder quantity was not sufficient to form a properly wetted fillet to all portions of the component termination or extend to the land edges.</p> <p>NASA-STD-8739.2 [12.8.2.b.6], [12.9.4.b.4]</p>

NASA WORKMANSHIP STANDARDS

 <p>NATIONAL AERONAUTICS AND SPACE ADMINISTRATION JOHNSON SPACE CENTER HOUSTON, TEXAS USA 77058</p>	<p>Released: 06.27.2002</p>	<p>Revision:</p>	<p>Revision Date:</p>
	<p>Book: 7</p>	<p>Section: 7.10</p>	<p>Page: 4</p>

**SURFACE MOUNT TECHNOLOGY (SMT)
INWARD-FORMED "L" LEAD PACKAGES (cont.)**

<p style="text-align: center;">ACCEPTABLE NONWETTING (SPECIAL EXCLUSION)</p> <p>Leads not having wettable sides (edges) by design (such as leads stamped from pre-plated stock) are not required to exhibit side fillets.</p> <p>Best Workmanship Practice</p>	<p style="text-align: center;">UNACCEPTABLE IMPROPER WETTING</p> <p>The solder fillet shall exhibit a positive wetting angle, wet all elements of the connection, and shall extend to the edge of the pad.</p> <p>NASA-STD-8739.2 [12.8.1.b], [12.9.4.b.4]</p>

<p>UNACCEPTABLE HEEL OVERHANG</p> <p>Heel overhang is prohibited. Heel overhang is an indicator of improper positioning, and typically prevents the formation of a properly wetted, concave heel fillet.</p> <p>Best Workmanship Practice</p>	<p>UNACCEPTABLE TOE OVERHANG (B)</p> <p>Toe overhang is prohibited. Toe overhang may result in reduced electrical clearance between the termination pads.</p> <p>Best Workmanship Practice</p>
--	---

NASA WORKMANSHIP STANDARDS			
 <p>NATIONAL AERONAUTICS AND SPACE ADMINISTRATION JOHNSON SPACE CENTER HOUSTON, TEXAS USA 77058</p>	Released:	Revision:	Revision Date:
	06.27.2002		
	Book:	Section:	Page:
	7	7.10	5



[Need a printed copy?](#)
(May take a while to load.)
Requires Adobe Reader.



[Need Adobe Reader?](#)
[Click here to download.](#)



[Questions? Suggestions?](#)

**SURFACE MOUNT TECHNOLOGY (SMT)
LEADED PACKAGES/PARTS-ROUND OR FLATTENED "COINED" LEADS**

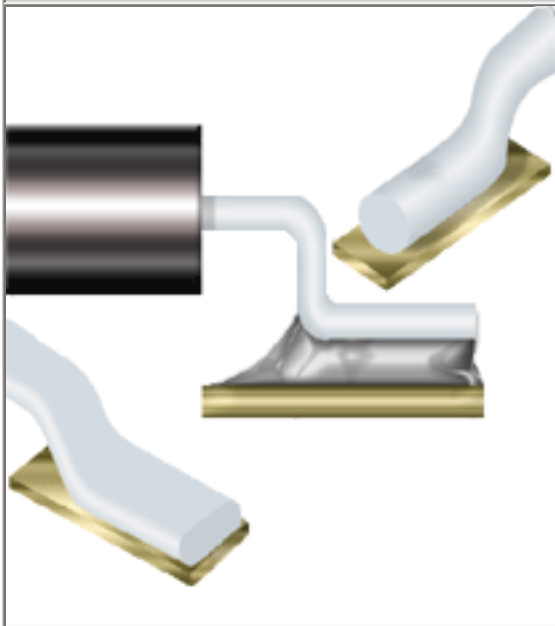

**LEADED PACKAGES/PARTS
ROUND OR FLATTENED (COINED)
LEADS**

This category encompasses discrete component and integrated circuit packages, which share requirements of through hole soldering ([NASA-STD-8739.3](#)) and surface mount technology soldering ([NASA-STD-8739.2](#)). In typical applications, the leads are formed and bent in a pattern configuration similar to "Gull-Wing" devices. Leads may be in the original round cross-section, or flattened to increase surface contact to the land/pad.

See Section 7.01 "Surface Mount Soldering, General Requirements", for common accept/reject criteria.

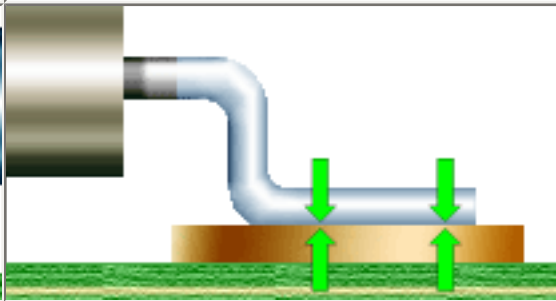
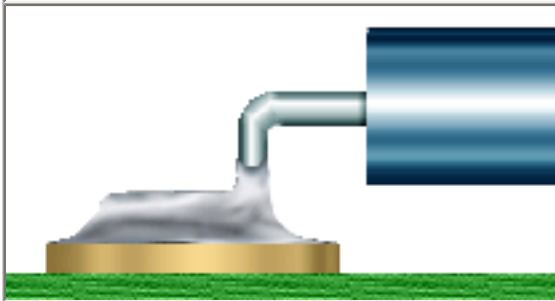

PREFERRED

The parts are properly oriented to the land pattern, with each lead centered across the width of the land. Lead feet are in full contact with the termination pad, fillets are shiny and concave and heel fillet is evident.

[NASA-STD-8739.2 \[12.8.1\]](#), [\[12.9.2.a\]](#)
[NASA-STD-8739.3 \[13.6\]](#)

**PREFERRED
COPLANARITY**

The lead's foot should be parallel to, and in full contact with the termination pad.

[NASA-STD-8739.2 \[7.1\]](#)
[NASA-STD-8739.3 \[8.5\]](#)

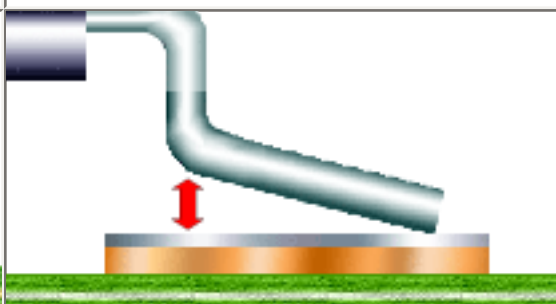
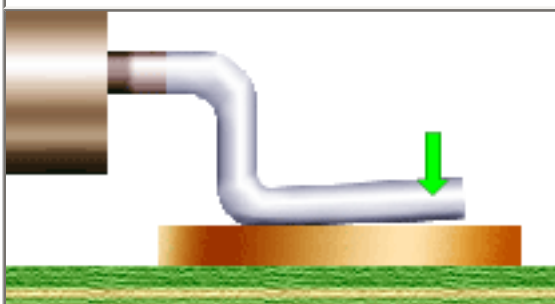

**ACCEPTABLE
COPLANARITY**

The maximum acceptable variation in planarity between any portion of the lead foot and the termination pad shall not exceed 0.26 mm (0.010").

[NASA-STD-8739.2 \[7.1\]](#), [\[12.8.1.h\]](#)
[NASA-STD-8739.3 \[8.5.1\]](#)

**UNACCEPTABLE
IMPROPER COPLANARITY**

Excessive non-planarity may result in open or mechanically weak solder terminations, excessive part tilt, or violate minimum electrical spacing requirements.

[NASA-STD-8739.2 \[12.8.2.a.10\]](#), [\[12.9.2.b.3\]](#)
[NASA-STD-8739.3 \[13.6.2.a.5\]](#), [\[13.6.2.a.22\]](#)

NASA WORKMANSHIP STANDARDS

Released: 06.27.2002	Revision:	Revision Date:
-------------------------	-----------	----------------



NATIONAL AERONAUTICS AND SPACE ADMINISTRATION
 JOHNSON SPACE CENTER
 HOUSTON, TEXAS USA 77058

Book:
7

Section:
7.11



Page:
1

SURFACE MOUNT TECHNOLOGY LEADED PACKAGES/PARTS-ROUND OR FLATTENED "COINED" LEADS (cont.)	
<p style="text-align: center;">ACCEPTABLE FOOT LENGTH (L)</p> <p>The foot length (L) shall be a minimum of 3.5 times to 5.5 times the lead diameter/thickness (W), or 1.27 mm (0.050 in), whichever is less. NASA-STD-8739.3 [8.5.1.a]</p>	<p style="text-align: center;">UNACCEPTABLE IMPROPER FOOT LENGTH</p> <p>The foot length shall be a minimum of 3.5 times to 5.5 times the lead diameter (W)/thickness, or 1.27 mm (0.050 in), whichever is less. NASA-STD-8739.3 [8.5.1.a]</p>
<p style="text-align: center;">MANDATORY HEEL FILLET</p> <p>A heel fillet is mandatory and shall have a positive contour. NASA-STD-8739.2 [12.9.2.a.1] NASA-STD-8739.3 [8.5.1]</p>	<p style="text-align: center;">UNACCEPTABLE MISSING HEEL FILLET</p> <p>A heel fillet is mandatory and shall exhibit a positive contour. NASA-STD-8739.2 [12.9.2.b.5] NASA-STD-8739.3 [8.5.1], [11.2.5]</p>

<p style="text-align: center;">ACCEPTABLE MAXIMUM HEEL FILLET HEIGHT (E)</p> <p>Solder may extend through the lower bend radius, but shall not extend into the upper bend radius. Solder shall exhibit a concave fillet and the lead contour shall be visible.</p> <p>NASA-STD-8739.2 [12.8.1.b], [12.8.2.b.16] NASA-STD-8739.3 [11.2.5.a]</p>	<p style="text-align: center;">ACCEPTABLE MINIMUM HEEL FILLET HEIGHT (F)</p> <p>Solder shall be equal to the minimum solder thickness (G) plus one (1) lead diameter/thickness. Solder shall exhibit a concave fillet and the lead contour shall be visible.</p> <p>Best Workmanship Practice</p>
--	--

NASA WORKMANSHIP STANDARDS			
 <p>NATIONAL AERONAUTICS AND SPACE ADMINISTRATION JOHNSON SPACE CENTER HOUSTON, TEXAS USA 77058</p>	Released:	Revision:	Revision Date:
	06.27.2002		
	Book:	Section:	Page:
7	7.11	2	

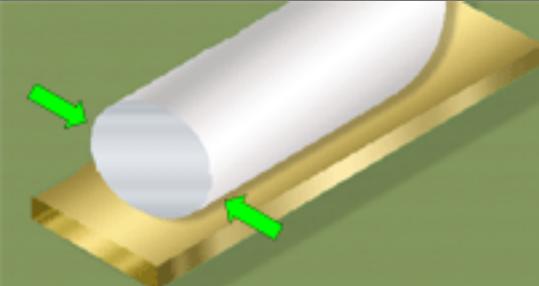
**SURFACE MOUNT TECHNOLOGY (SMT)
LEADED PACKAGES/PARTS-ROUND OR FLATTENED "COINED" LEADS
(cont.)**

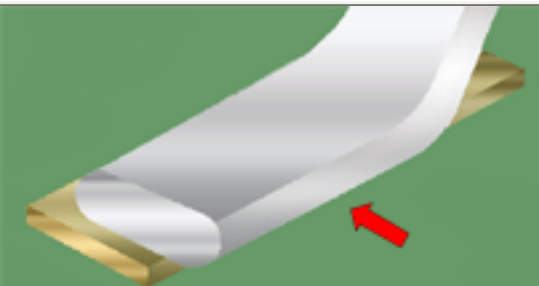
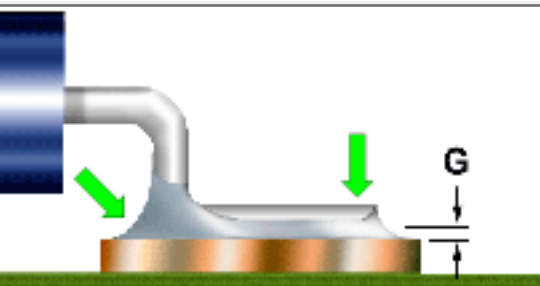
	
<p>PREFERRED LATERAL/SIDE OVERHANG</p> <p>The component lead is centered on the land, with no lateral/side overhang.</p> <p>NASA-STD-8739.3 [8.5.1.b]</p>	<p>ACCEPTABLE LATERAL/SIDE OVERHANG</p> <p>One edge of the lead may be flush with the edge of the solder pad.</p> <p>NASA-STD-8739.3 [8.5.1.b]</p>
	
<p>UNACCEPTABLE LATERAL/SIDE OVERHANG</p> <p>The lead shall not overhang the land edge.</p> <p>NASA-STD-8739.3 [8.5.1.b], [11.2.5]</p>	<p>ACCEPTABLE MINIMUM SOLDER THICKNESS (G)</p> <p>Terminations must have sufficient solder to form a properly wetted fillet, exhibiting a proper heel and toe fillet and a complete side fillet of minimum height.</p> <p>NASA-STD-8739.2 [12.9.2.a.1] NASA-STD-8739.3 [13.6.1]</p>

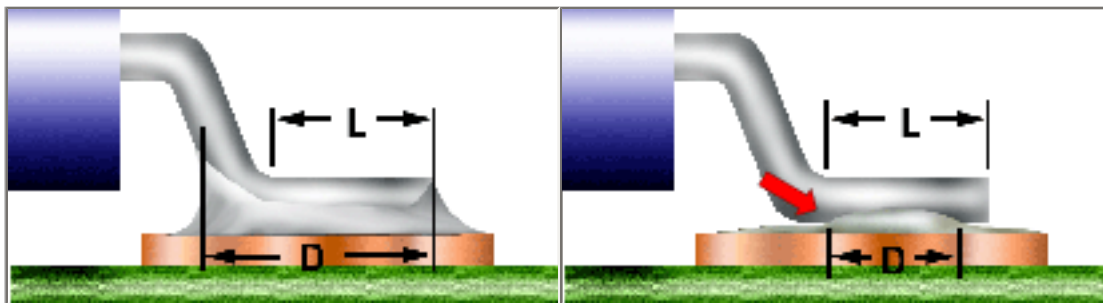

**ACCEPTABLE
SIDE JOINT FILLET (D)**

The side joint fillet (D) shall be present, equal to the lead length (L) plus the heel fillet, and exhibit complete wetting and a positive contour.

[NASA-STD-8739.3 \[8.5.1\]](#)

**UNACCEPTABLE
INSUFFICIENT SIDE JOINT FILLET (D)**

The side joint fillet (D) shall be present, equal to the lead length (L) plus the heel fillet, and exhibit complete wetting and a positive contour.

[NASA-STD-8739.3 \[8.5.1\]](#)

NASA WORKMANSHIP STANDARDS



**NATIONAL AERONAUTICS AND
SPACE ADMINISTRATION**
JOHNSON SPACE CENTER
HOUSTON, TEXAS USA 77058

Released:
06.27.2002

Revision:

Revision Date:

Book:
7

Section:
7.11

Page:
3

**SURFACE MOUNT TECHNOLOGY (SMT)
LEADED PACKAGES/PARTS-ROUND OR FLATTENED "COINED" LEADS
(cont.)**

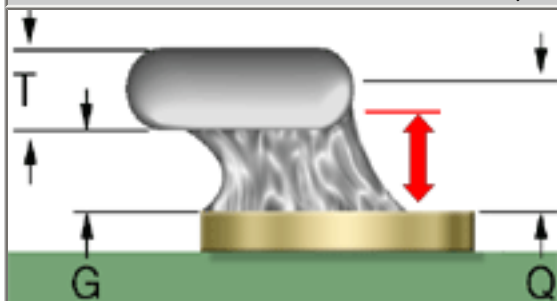

**UNACCEPTABLE
SIDE FILLET HEIGHT (Q)**

The side fillet height (Q) shall be equal to or greater than the minimum solder thickness (G), plus 50% lead diameter/thickness (T). Image also shows side overhang.

[Best Workmanship Practice](#)

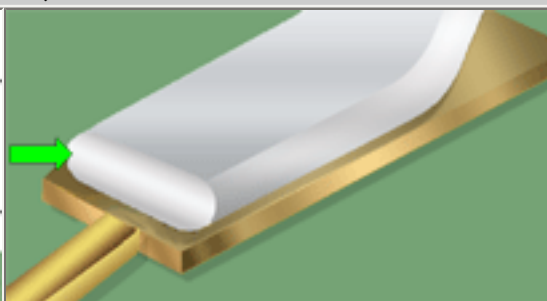

**MANDATORY
TOE OFFSET**

The end of the lead shall be a minimum of 0.25 mm (0.010 in.) from the end of the pad. Overhang is prohibited.

[NASA-STD-8739.3 \[8.5.1\]](#)

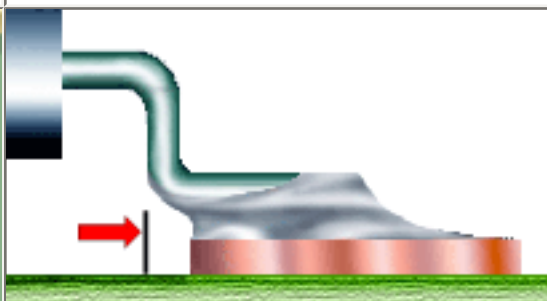
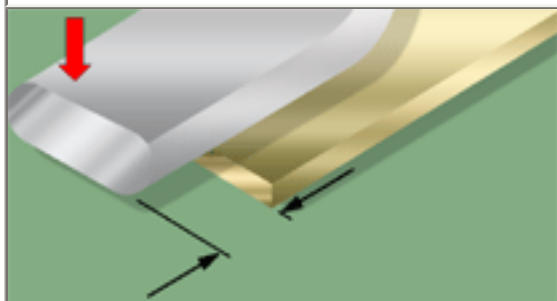

<p>UNACCEPTABLE TOE OVERHANG</p> <p>Toe overhang is prohibited. NASA-STD-8739.3 [13.6.2.a.5]</p>	<p>UNACCEPTABLE HEEL OVERHANG</p> <p>Heel overhang is prohibited. NASA-STD-8739.3 [8.5], [13.6.2.a.5], [13.6.2.a.11]</p>
--	--

NASA WORKMANSHIP STANDARDS			
 <p>NATIONAL AERONAUTICS AND SPACE ADMINISTRATION JOHNSON SPACE CENTER HOUSTON, TEXAS USA 77058</p>	Released: 06.27.2002	Revision:	Revision Date:
	Book: 7	Section: 7.11	Page: 4



[Need a printed copy?](#)
(May take a while to load.)
 Requires Adobe Reader.



[Need Adobe Reader?](#)
[Click here to download.](#)



[Questions? Suggestions?](#)

**SURFACE MOUNT TECHNOLOGY (SMT)
LEADLESS CHIP CARRIERS "LLCC"**

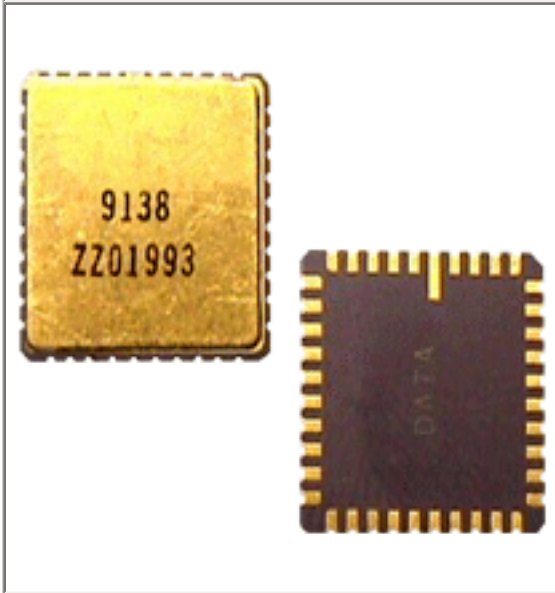

LEADLESS CHIP CARRIERS

Leadless Chip Carriers (LLCC) packages are characterized by external connections consisting of metallized inset terminations (a castellation), making the package resemble a miniature castle.

The use of LLCC packages is not recommended for high reliability/spaceflight applications, due to the limited mechanical reliability of the terminations.

See Section 7.01 "Surface Mount Soldering, General Requirements", for common accept/reject criteria.

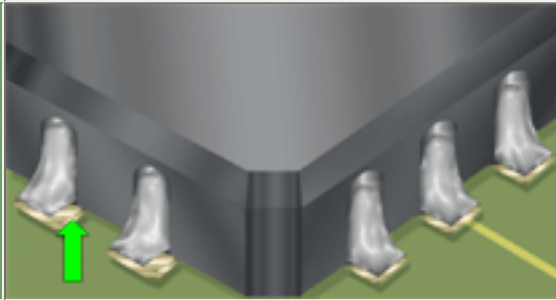
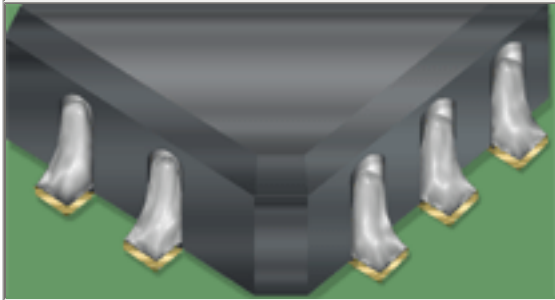

PREFERRED

The part is centered with the castellations centered across the width of the land pattern area and properly oriented. Solder fillets exhibit complete wetting, proper thickness and positive angle.

[NASA-STD-8739.2 \[12.8.1\], \[12.9.7.a\]](#)

ACCEPTABLE

The part is not centered, but the castellations are on the land pattern (there is no side overhang).

[NASA-STD-8739.2 \[12.8.1\], \[12.9.7.a\]](#)

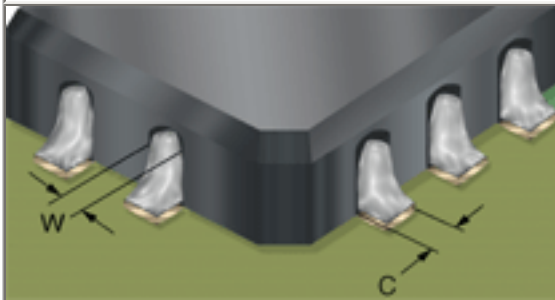

**ACCEPTABLE
END JOINT WIDTH (C)**

The width of the solder joint shall be equal to the castellation width (W).

[NASA-STD-8739.2 \[12.8.1\], \[12.9.7.a\]](#)

**ACCEPTABLE
MAXIMUM FILLET HEIGHT (E)**



The fillet shall extend to the edge of the castellation metallization, and shall have a positive wetting angle.

[NASA-STD-8739.2 \[12.8.1\], \[12.9.7.a\]](#)



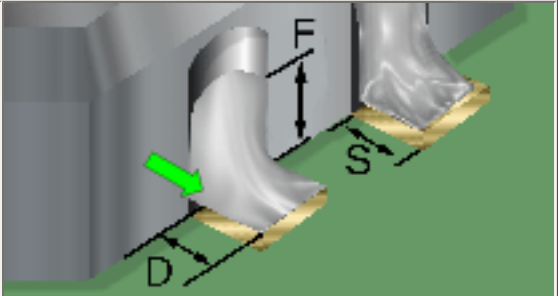
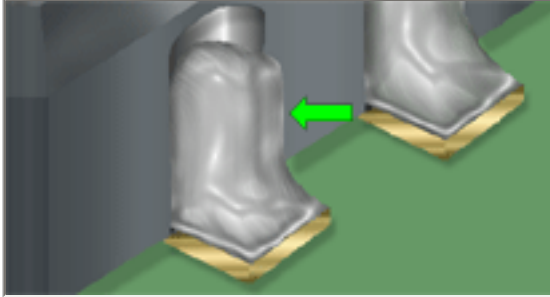

NASA WORKMANSHIP STANDARDS

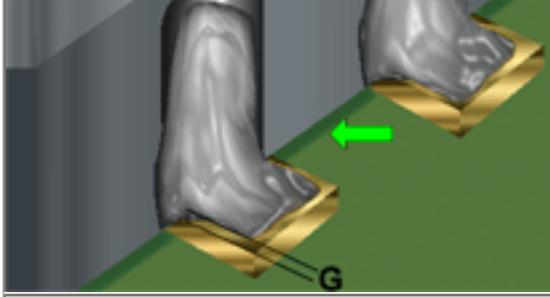
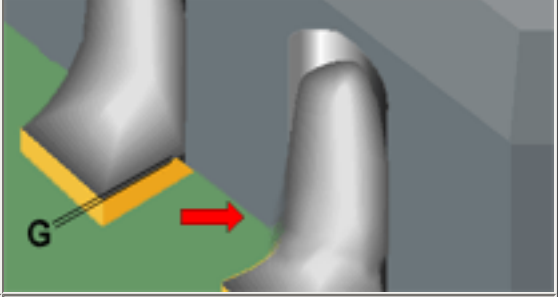
 <p>NATIONAL AERONAUTICS AND SPACE ADMINISTRATION JOHNSON SPACE CENTER HOUSTON, TEXAS USA 77058</p>	Released: 06.27.2002	Revision:	Revision Date:

	Book: 7	Section: 7.12	Page: 1
--	------------	------------------	------------

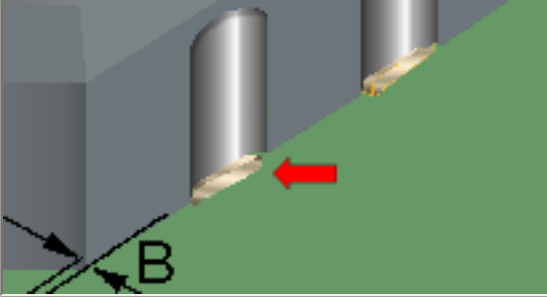
SURFACE MOUNT TECHNOLOGY LEADLESS CHIP CARRIERS "LLCC"(cont.)	
	
<p>ACCEPTABLE MINIMUM FILLET HEIGHT (F)</p> <p>The solder fillet shall extend upwards at least 75% to the castellation metallization, and shall have a positive wetting angle.</p> <p>NASA-STD-8739.2 [12.9.7.b.2]</p>	<p>ACCEPTABLE SIDE JOINT LENGTH (D)</p> <p>The length of the side joint(D) shall be 50% of the minimum fillet height (F), or the land length external to the package (S), whichever is less.</p> <p>NASA-STD-8739.2 [12.9.7.a]</p>
	
<p>ACCEPTABLE SOLDER FILLET</p> <p>The solder fillet may have a bulbous appearance, but shall be well-wetted and exhibit a positive angle at the castellation and pad terminus.</p> <p>NASA-STD-8739.2 [12.9.7.a]</p>	<p>UNACCEPTABLE EXCESS SOLDER</p> <p>The solder fillet shall not exhibit a negative wetting angle at the top of the termination and/or at the edge of the land area.</p> <p>NASA-STD-8739.2 [12.9.7.b.3]</p>
	
<p>ACCEPTABLE SOLDER THICKNESS (G)</p> <p>The solder thickness shall elevate the chip body by at least 0.127 mm (0.005 in.) above the printed wiring board surface, unless satisfactory cleaning can be demonstrated with reduced clearance.</p> <p>NASA-STD-8739.2 [12.9.7.a.3]</p>	<p>UNACCEPTABLE INADEQUATE SOLDER THICKNESS (G)</p> <p>A spacing of less than 0.127 mm (0.005 in.) between the chip body and the printed wiring board surface may prevent removal of flux and solder fines from underneath the chip</p> <p>NASA-STD-8739.2 [12.9.7.a.3]</p>

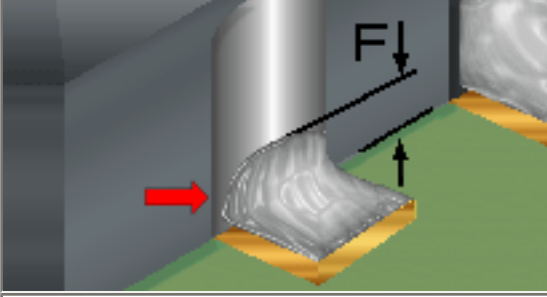
NASA WORKMANSHIP STANDARDS			
 <p>NATIONAL AERONAUTICS AND SPACE ADMINISTRATION JOHNSON SPACE CENTER HOUSTON, TEXAS USA 77058</p>	Released: 06.27.2002	Revision:	Revision Date:
	Book: 7	Section: 7.12	Page: 2

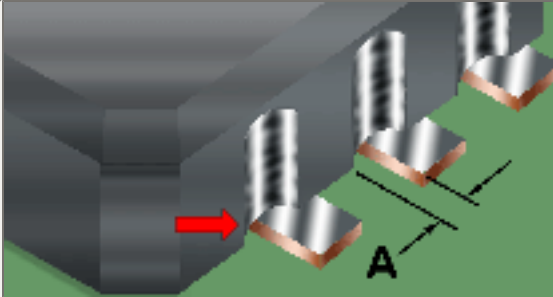
SURFACE MOUNT TECHNOLOGY (SMT) LEADLESS CHIP CARRIERS "LLCC"(cont.)	
	
<p>UNACCEPTABLE END OVERHANG (B)</p> <p>End overhang of the edge of the chip body (with respect to the pad termination end) is not permitted.</p> <p>NASA-STD-8739.2 [12.6.2.9]</p>	<p>UNACCEPTABLE IMPROPER WETTING</p> <p>The solder fillet shall exhibit a positive wetting angle, wet all elements of the connection, and shall extend to the edge of the pad.</p> <p>NASA-STD-8739.2 [12.9.7.a.1]</p>
	
<p>UNACCEPTABLE INSUFFICIENT SOLDER</p> <p>The minimum fillet height (F) shall not be less than 75% of the castellation thickness.</p> <p>NASA-STD-8739.2 [12.8.2.b.6], [12.9.7.b.2]</p>	<p>UNACCEPTABLE NONWETTING</p> <p>The fillet shall not exhibit non-wetting at the top of the solder fillet.</p> <p>NASA-STD-8739.2 [12.9.7.b.4]</p>
	

<p>UNACCEPTABLE POOR FLOW</p> <p>The fillet shall not exhibit poor or uneven flow at the top of the solder fillet.</p> <p>NASA-STD-8739.2 [12.9.7.b.4]</p>	<p>UNACCEPTABLE SIDE OVERHANG (A)</p> <p>The castellation shall not overhang the edge of the land.</p> <p>NASA-STD-8739.2 [12.9.7.b.1]</p>
---	---

NASA WORKMANSHIP STANDARDS			
 <p>NATIONAL AERONAUTICS AND SPACE ADMINISTRATION JOHNSON SPACE CENTER HOUSTON, TEXAS USA 77058</p>	Released: 06.27.2002	Revision:	Revision Date:
	Book: 7	Section: 7.12	Page: 3



[Need a printed copy?](#)
(May take a while to load.)
Requires Adobe Reader.



[Need Adobe Reader?](#)
[Click here to download.](#)



[Questions? Suggestions?](#)

SURFACE MOUNT TECHNOLOGY (SMT)
BALL GRID ARRAY-BGA

BALL GRID ARRAY-BGA



Ball Grid Array packages were designed to provide a device having high density input/output (I/O) array pattern interconnects, while minimizing device footprint and temperature coefficient (TC) problems. The array design features a low profile with shorter interconnections-resulting in superior electrical performance, speed, heat dissipation and noise reduction.

The placement of the interconnects on the bottom of the package limits visual inspection of the inner terminations, requiring the use of special microscopes or three-dimensional X-ray.

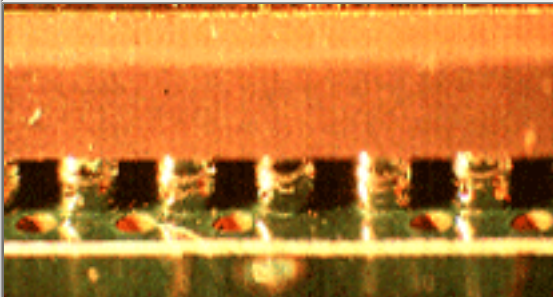

PREFERRED

Solder terminations are smooth and rounded, with a clearly defined boundary. Terminations exhibit no voids, and are of the same diameter, volume, darkness and contrast. Registration is straight, with no pad overhang or rotation. No solder balls are present.

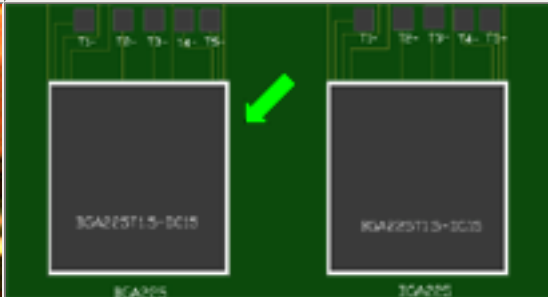

PREFERRED
FIDUCIAL ALIGNMENT

Alignment within the fiducial marks provides a rapid, visual indication of proper device alignment.

[Best Workmanship Practice](#)

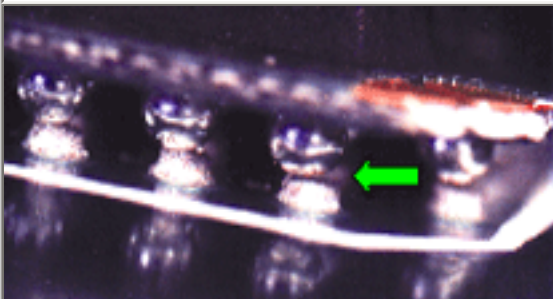

ACCEPTABLE
PAD OVERHANG

Pad overhang is less than 25%.

[Best Workmanship Practice](#)

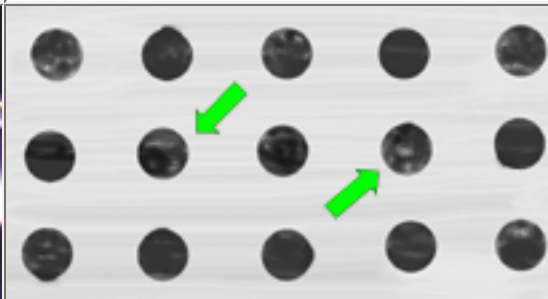

ACCEPTABLE
VOIDS

Terminations that exhibit less than 10% voiding in the ball-to-board interface are acceptable.

[Best Workmanship Practice](#)

NASA WORKMANSHIP STANDARDS

 NATIONAL AERONAUTICS AND SPACE ADMINISTRATION JOHNSON SPACE CENTER HOUSTON, TEXAS USA 77058	Released: 06.27.2002	Revision:	Revision Date:
	Book: 7	Section: 7.13	Page: 1

**SURFACE MOUNT TECHNOLOGY
BALL GRID ARRAY-BGA(cont.)**

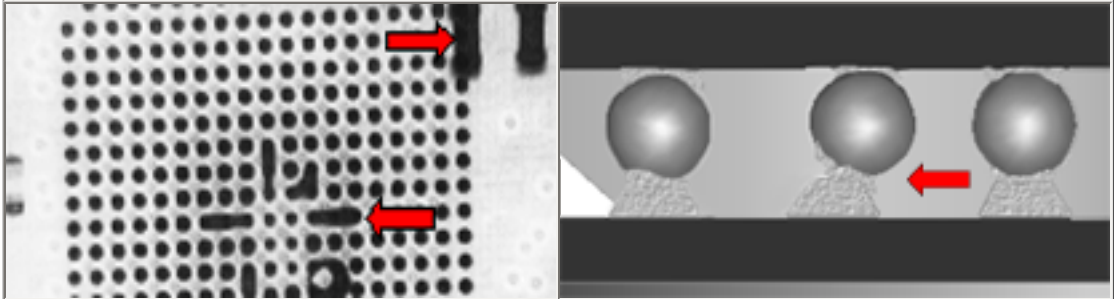

**UNACCEPTABLE
DARK SPOTS**

Dark spots in the x-ray view, which cannot be attributed to circuitry (traces) or components underneath the BGA, shall be cause for rejection.

[Best Workmanship Practice](#)

**UNACCEPTABLE
EXCESSIVE PAD OVERHANG**

Pad overhang shall not exceed 25%.

[Best Workmanship Practice](#)

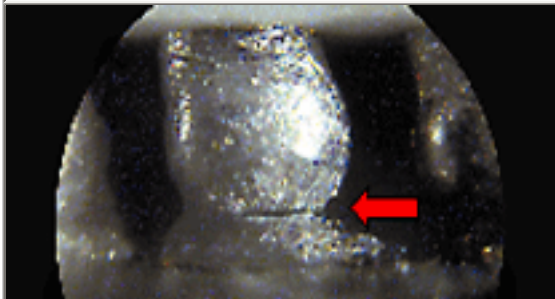

**UNACCEPTABLE
FRACTURE**

Terminations exhibiting fractures in the ball-to board interface are unacceptable.

[Best Workmanship Practice](#)

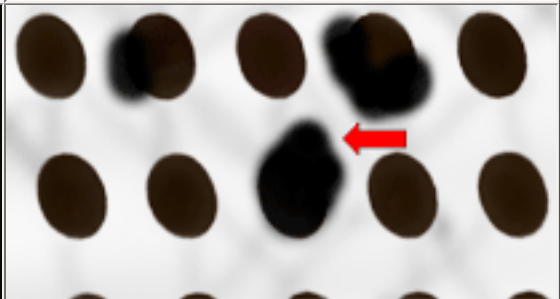

**UNACCEPTABLE
MISALIGNMENT**

Misalignment is an indicator of improper process controls.

[Best Workmanship Practice](#)

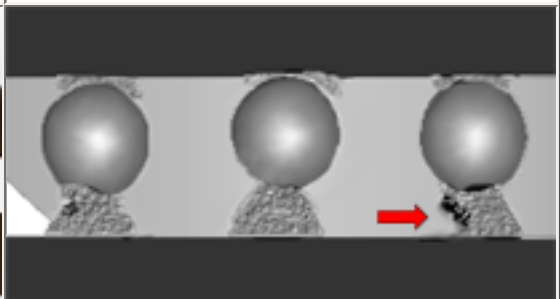

<p>UNACCEPTABLE MISSING BALL</p> <p>BGAs exhibiting missing solder balls shall be rejected. Best Workmanship Practice</p>	<p>UNACCEPTABLE MISSING SOLDER</p> <p>Missing solder is an indicator of improper process controls. Best Workmanship Practice</p>
--	---

NASA WORKMANSHIP STANDARDS			
 <p>NATIONAL AERONAUTICS AND SPACE ADMINISTRATION JOHNSON SPACE CENTER HOUSTON, TEXAS USA 77058</p>	Released: 06.27.2002	Revision:	Revision Date:
	Book: 7	Section: 7.13	Page: 2

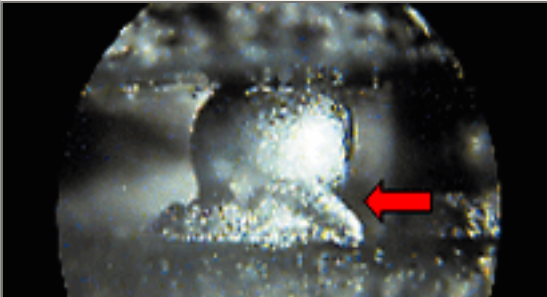
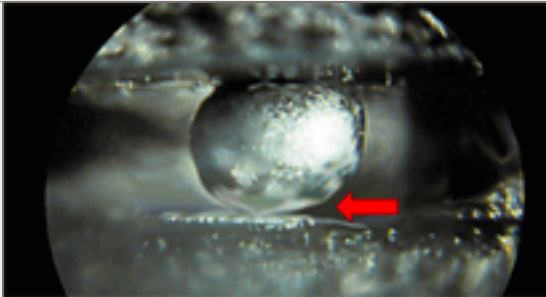
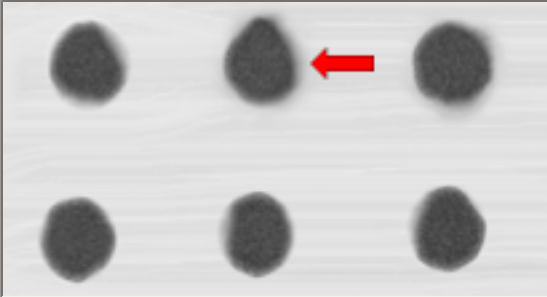
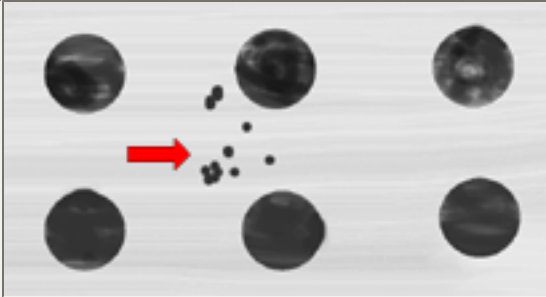
SURFACE MOUNT TECHNOLOGY (SMT) BALL GRID ARRAY-BGA(cont.)	
	
<p>UNACCEPTABLE NON-REFLOW</p> <p>Lack of proper reflow indicates poor process controls, typically insufficient heat during reflow. Best Workmanship Practice</p>	<p>UNACCEPTABLE NON-WETTING</p> <p>Non-wetting is an indicator of poor process controls. Best Workmanship Practice</p>
	
<p>UNACCEPTABLE POOR DEFINITION</p> <p>Solder joint boundaries exhibiting poor definition, appear fuzzy, or which blend in with the background, indicate insufficient reflow. Best Workmanship Practice</p>	<p>UNACCEPTABLE SOLDER BALLS</p> <p>Solder ball(s) that violate the minimum electrical clearance shall be cause for rejection. Best Workmanship Practice</p>

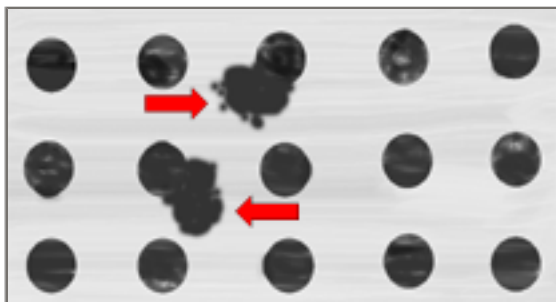
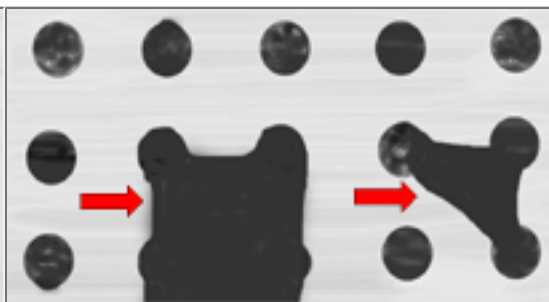
	
<p style="text-align: center;">UNACCEPTABLE SOLDER BALLS</p> <p>Solder balls that bridge more than 25% of the distance between the leads shall be cause for rejection.</p> <p>Best Workmanship Practice</p>	<p style="text-align: center;">UNACCEPTABLE SOLDER BRIDGE</p> <p>Solder bridging is an indicator of improper process, typically excess paste deposit.</p> <p>Best Workmanship Practice</p>

NASA WORKMANSHIP STANDARDS				
	<p>NATIONAL AERONAUTICS AND SPACE ADMINISTRATION JOHNSON SPACE CENTER HOUSTON, TEXAS USA 77058</p>	<p>Released: 06.27.2002</p>	<p>Revision:</p>	<p>Revision Date:</p>
		<p>Book: 7</p>	<p>Section: 7.13</p>	<p>Page: 3</p>

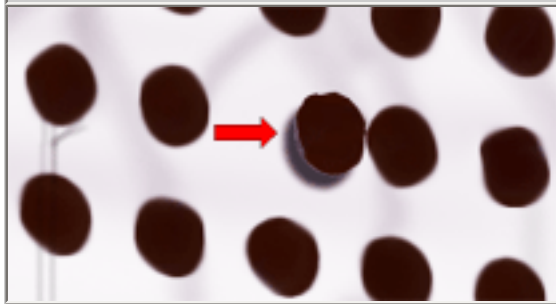
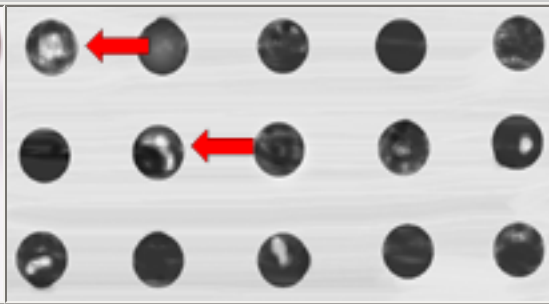
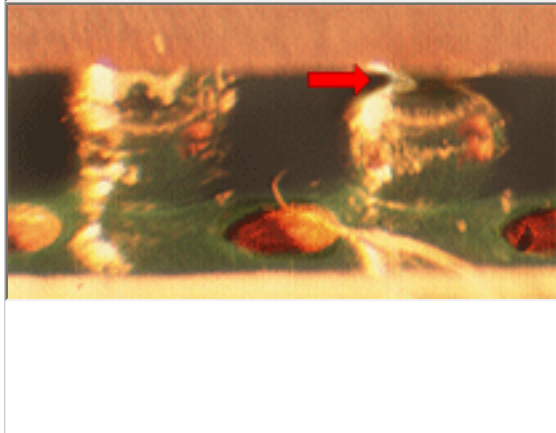
SURFACE MOUNT TECHNOLOGY (SMT) BALL GRID ARRAY-BGA (cont.)	
	
<p style="text-align: center;">UNACCEPTABLE SOLDER OPENS</p> <p>Solder opens are an indicator of improper process, typically insufficient paste deposit.</p> <p>Best Workmanship Practice</p>	<p style="text-align: center;">UNACCEPTABLE VOIDING</p> <p>Terminations that exhibit 10% (or more) voiding in the ball-to-board interface shall be grounds for rejection.</p> <p>Best Workmanship Practice</p>
	

UNACCEPTABLE
POOR FLOW

The fillet shall not exhibit poor or uneven flow at the top of the solder fillet.

[Best Workmanship Practice](#)

NASA WORKMANSHIP STANDARDS			
 NATIONAL AERONAUTICS AND SPACE ADMINISTRATION JOHNSON SPACE CENTER HOUSTON, TEXAS USA 77058	Released: 06.27.2002	Revision:	Revision Date:
	Book: 7	Section: 7.13	Page: 4



[Need a printed copy?](#)
(May take a while to load.)
Requires Adobe Reader.



[Need Adobe Reader?](#)
[Click here to download.](#)



[Questions? Suggestions?](#)

CONFORMAL COATING AND STAKING (BONDING)
GENERAL REQUIREMENTS

GENERAL REQUIREMENTS

Reliable staking and conformal coating results from proper design, control of equipment, materials, work environments and careful workmanship by trained and certified personnel.

The staking and conformal coating materials shall have dielectric properties that will meet the minimum circuit requirements in all anticipated environments. The materials shall be compatible, noncorrosive and curable under conditions that will not change or adversely affect the performance or reliability of the parts on the PWA.

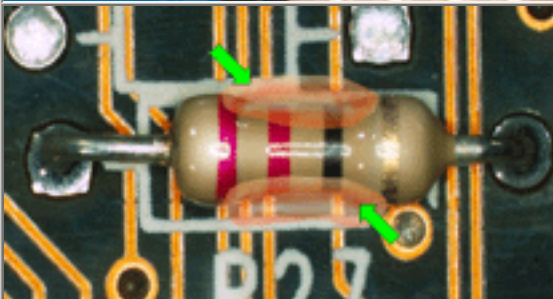
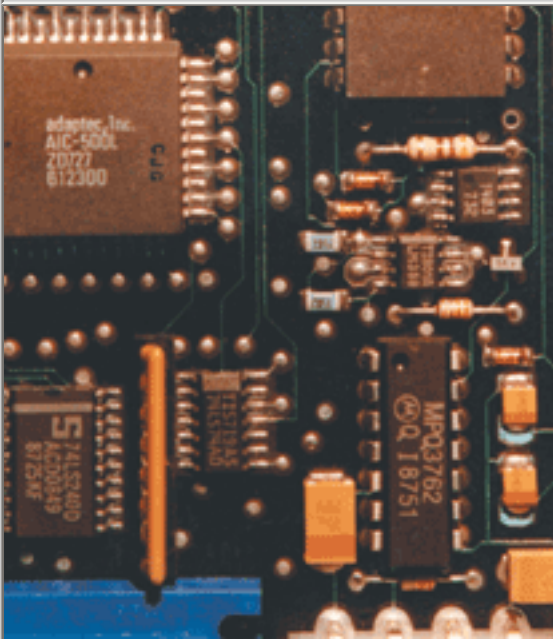

PREFERRED
ADHESIVE BONDING/STAKING

Adhesive bonding/staking material has been applied to the parts and locations specified by the approved engineering specification. Material quantity is sufficient to provide required support, but does not negate stress relief or mechanically compromise hardware reliability.

PREFERRED
CONFORMAL COATING

Coating covers all areas as specified on the engineering documentation. coating exhibits uniform color, thickness, proper adhesion, is smooth and tack free. No bubbles, entrapped contaminants or particles, excessive fillets, runs, drips, etc.

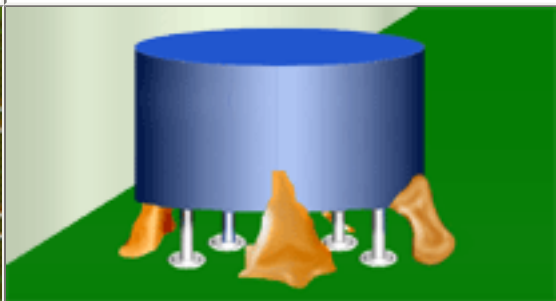
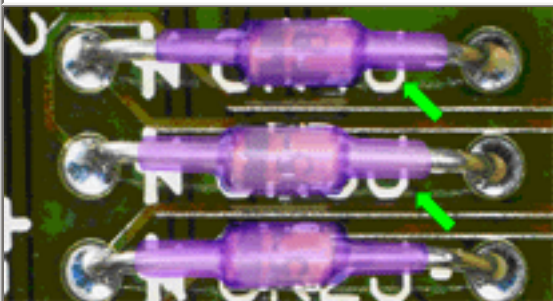

PREFERRED
GLASS-BODIED PARTS

Glass encased parts (i.e. diodes, etc.) shall be covered with transparent, resilient sleeving or other approved material, prior to staking or conformal coating with a rigid material.

[NASA-STD-8739.1 \[9.2.3.c\], \[11.6.3.e\]](#)
[NASA-STD-8739.3 \[8.1.4\]](#)

PREFERRED
3.5 GM PER LEAD/7 GM TOTAL RULE

Components weighing 7 grams (0.25 oz.) total, or 3.5 grams (0.12 oz.) per lead, shall be bonded to the mounting surface, in at least four evenly spaced places around component, when no other mechanical support is used.

[Best Workmanship Practice](#)

NASA WORKMANSHIP STANDARDS

Released: 04.05.2002	Revision:	Revision Date:
-------------------------	-----------	----------------



NATIONAL AERONAUTICS AND SPACE ADMINISTRATION
JOHNSON SPACE CENTER
HOUSTON, TEXAS USA 77058

Book:
8

Section:
8.01

Page:
1

CONFORMAL COATING AND STAKING (BONDING)
GENERAL REQUIREMENTS (cont.)



PREFERRED
TANTALUM CAPACITORS

All axial-leaded solid-slug tantalum capacitors shall be staked.

[NASA-STD-8739.1 \[9.2.4\], \[11.6.3.d\]](#)

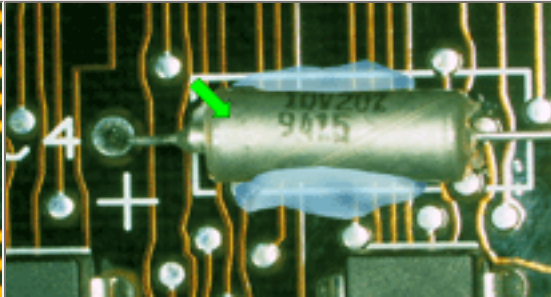

PREFERRED
UNINSULATED METALLIC-CASED
COMPONENT

Metallic-cased components mounted over printed conductors or which are in close proximity to uncommon conductive surfaces shall be separated by insulation of suitable thickness.

[NASA-STD-8739.3 \[8.1.2.b\]](#)



UNACCEPTABLE
ADJUSTABLE COMPONENTS

The adjustable portion of adjustable components (i.e. potentiometers, variable capacitors, etc.), as well as electrical and mating surfaces shall be left uncoated.

[Best Workmanship Practice](#)

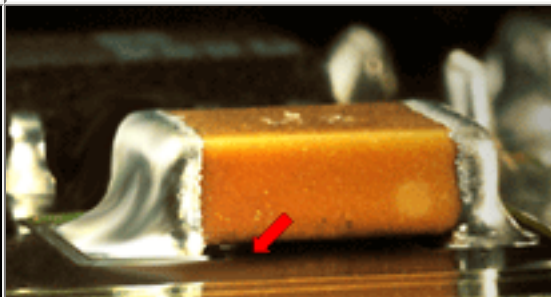

UNACCEPTABLE
BRIDGING/UNDERFILL

Conformal coating and/or staking materials shall not be allowed to bridge between the bottom of ceramic-bodied DIPs, flatpacks or surface mounted parts and the PWB.

[NASA-STD-8739.1 \[9.2.1\], \[11.6.3.b\]](#)

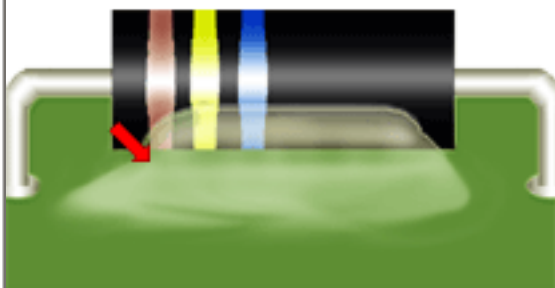

UNACCEPTABLE
CONFORMAL COAT USED AS STAKING
Conformal coating shall not be used as a staking material.
Components should be properly staked prior to being conformally coated.
[Best Workmanship Practice](#)

NASA WORKMANSHIP STANDARDS			
 NATIONAL AERONAUTICS AND SPACE ADMINISTRATION JOHNSON SPACE CENTER HOUSTON, TEXAS USA 77058	Released: 04.05.2002	Revision:	Revision Date:
	Book: 8	Section: 8.01	Page: 2



[Need a printed copy?](#)
(May take a while to load.)
Requires Adobe Reader.



[Need Adobe Reader?](#)
[Click here to download.](#)



[Questions? Suggestions?](#)

CONFORMAL COATING AND STAKING (BONDING)
ADHESIVE BONDING/STAKING

ADHESIVE BONDING/STAKING

The primary purpose for adhesive bonding/staking is to protect and support components and parts that may be damaged by vibration, shock or handling. Bonding/staking material may either be resilient or rigid.

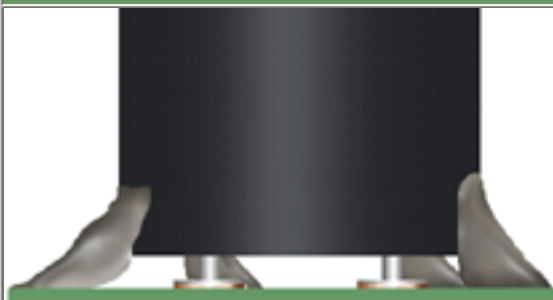
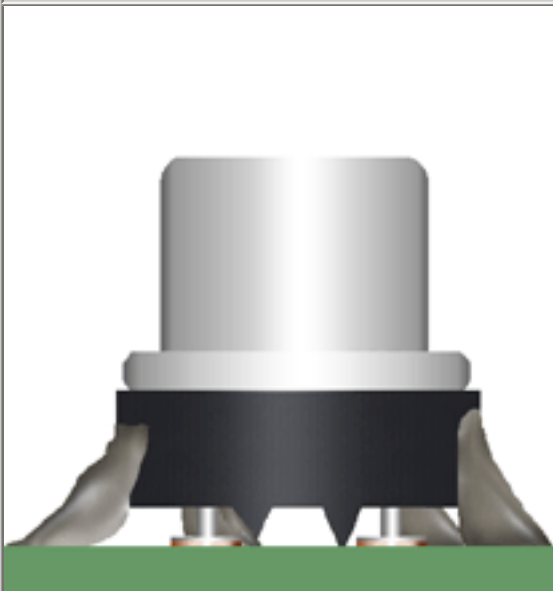

PREFERRED
ADHESIVE BONDING/STAKING

Adhesive bonding/staking material has been applied to the parts and locations specified by the approved engineering specification. Material quantity is sufficient to provide required support, but does not negate stress relief or mechanically compromise hardware reliability.

PREFERRED
FLEXIBLE MATERIALS

Flexible staking materials with a high thermal expansion coefficient shall not be applied where excessive stress may be damaging. As depicted, the staking material has been applied to the corners of the package.

[NASA-STD-8739.1 \[9.2.1\]](#)

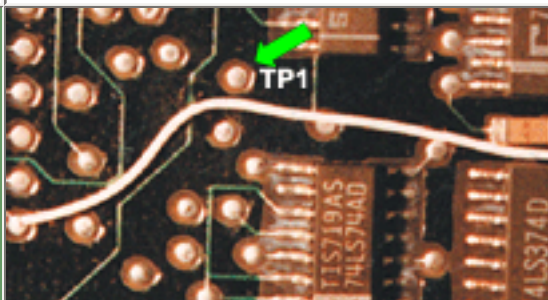
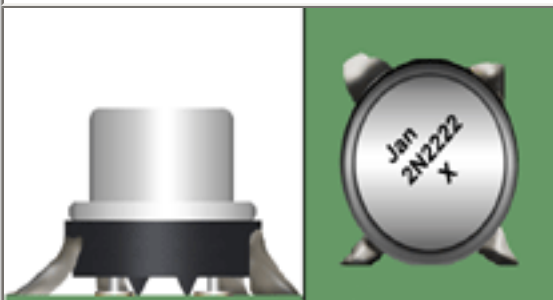

PREFERRED
PERIPHERY RULE

Staking material shall be of sufficient quantity to result in a minimum of 20% of the component's periphery being bonded.

[Best Workmanship Practice](#)

PREFERRED
SOLDERABLE AREAS/TEST POINTS

Adhesive/staking material shall not be applied to areas that are to be soldered, or are to be used as test points. Contamination/solderability issue.

[Best Workmanship Practice](#)

NASA WORKMANSHIP STANDARDS



NATIONAL AERONAUTICS AND SPACE ADMINISTRATION
JOHNSON SPACE CENTER
HOUSTON, TEXAS USA 77058

Released:
04.05.2002

Revision:

Revision Date:

	Book: 8	Section: 8.02	Page: 1
--	------------	------------------	------------

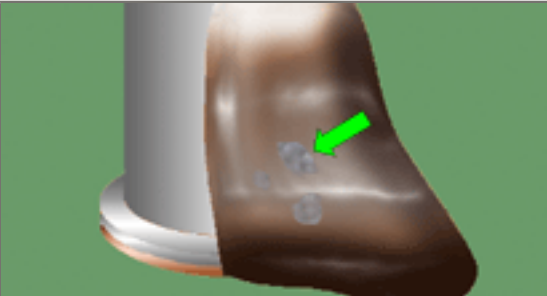
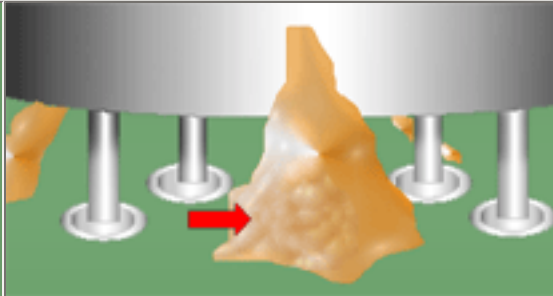
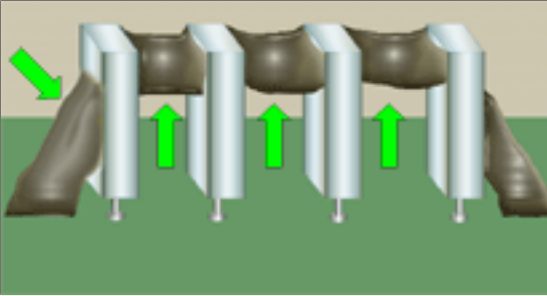
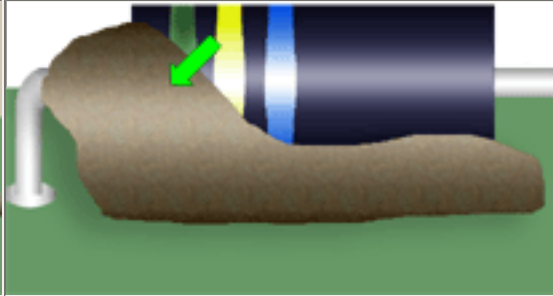
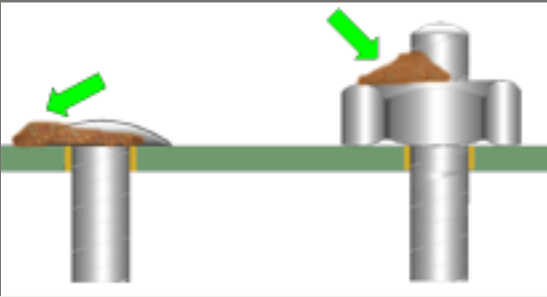
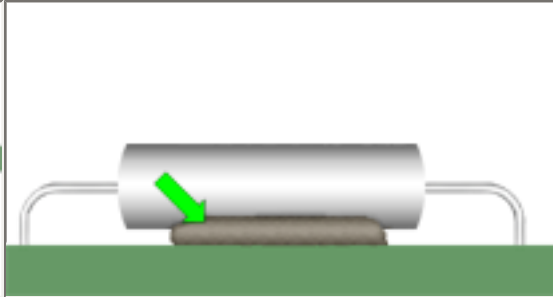
CONFORMAL COATING AND STAKING (BONDING) ADHESIVE BONDING/STAKING (cont.)	
	
<p>ACCEPTABLE BUBBLES</p> <p>Minor bubbles in the staking material fillet are acceptable, provided they do not reduce the fillet's cross-section below minimum requirements.</p> <p>Best Workmanship Practice</p>	<p>UNACCEPTABLE BUBBLES</p> <p>Bubbles shall not reduce the cross-section of the fillet below minimum requirements.</p> <p>Best Workmanship Practice</p>
	
<p>ACCEPTABLE BRIDGING ARRAYS</p> <p>Staking material may be applied across the top of the array of parts, provided the staking covers the entire width of the top of the parts, exhibits a fillet a minimum of 2/3 of part width on each end of the array, and stress relief is not negated.</p> <p>NASA-STD-8739.1 [9.2.1]</p>	<p>ACCEPTABLE EXCESSIVE FILLET</p> <p>Staking material exceeds 50% of the component diameter, but does not extend over the component, obliterate markings, or negate component lead stress relief.</p> <p>NASA-STD-8739.1 [9.2.1], [9.2.3.a]</p>
	

<p>ACCEPTABLE FASTENER SPOT STAKING</p> <p>Staking materials shall be applied to fasteners per engineering documentation.</p> <p>NASA-STD-8739.1 [9.2.1]</p>	<p>ACCEPTABLE HORIZONTAL MOUNT AXIAL</p> <p>Staking adheres to component a minimum of 50% of its length (L) and 25% of its diameter (D), on one side, and is centered. Proper wetting and adhesion to the part and substrate is evident.</p> <p>NASA-STD-8739.1 [9.2.1]</p>
--	---

NASA WORKMANSHIP STANDARDS			
 <p>NATIONAL AERONAUTICS AND SPACE ADMINISTRATION JOHNSON SPACE CENTER HOUSTON, TEXAS USA 77058</p>	Released:	Revision:	Revision Date:
	04.05.2002		
	Book:	Section:	Page:
	8	8.02	2

CONFORMAL COATING AND STAKING (BONDING)
ADHESIVE BONDING/STAKING (cont.)

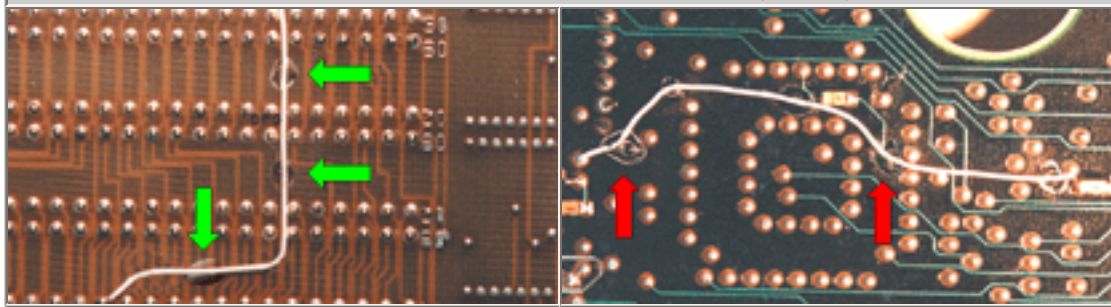

**ACCEPTABLE
JUMPER WIRES**

Jumper wires shall be staked every 2.54 cm (1 in.), at a minimum, and at every change of direction outside of the radius of curvature.

[NASA-STD-8739.1 \[9.2.4\], \[11.6.2.c\]](#)

**UNACCEPTABLE
BONDS IN WIRE CURVATURE**

Staking along a jumper wire's radius of curvature can negate strain relief, resulting in reliability concerns.

[NASA-STD-8739.1 \[9.2.4\]](#)

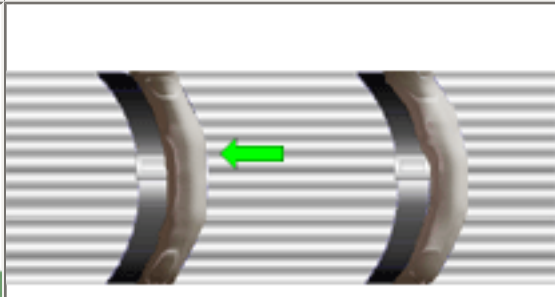

**ACCEPTABLE
MULTIPLE VERTICAL AXIALS**

Staking adheres to each component for at least 50% of each component's length (L), is continuous between components, and adheres to each component a minimum of 25% of its circumference.

[Best Workmanship Practice](#)

**ACCEPTABLE
SPOT TIES ON WIRE BUNDLES**

Spot ties on wire bundles shall be staked per engineering documentation.

[NASA-STD-8739.1 \[9.2.1\]](#)

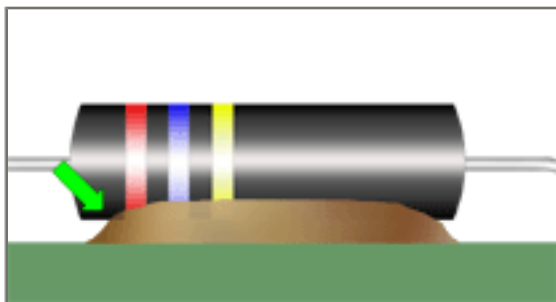
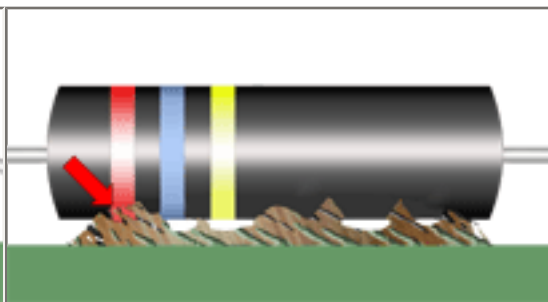
	
<p style="text-align: center;">ACCEPTABLE SUBSTRATE CONTACT</p> <p>The staking material shall wet and adhere to a minimum of 50% of component length (L), and 25% of circumference, depending on mounting configuration.</p> <p>Best Workmanship Practice</p>	<p style="text-align: center;">UNACCEPTABLE INSUFFICIENT SUBSTRATE CONTACT</p> <p>The staking material shall wet and adhere to a minimum of 50% of component length (L), 25% of circumference, depending on mounting configuration.</p> <p>Best Workmanship Practice</p>

NASA WORKMANSHIP STANDARDS				
	<p>NATIONAL AERONAUTICS AND SPACE ADMINISTRATION JOHNSON SPACE CENTER HOUSTON, TEXAS USA 77058</p>	<p>Released: 04.05.2002</p>	<p>Revision:</p>	<p>Revision Date:</p>
		<p>Book: 8</p>	<p>Section: 8.02</p>	<p>Page: 3</p>

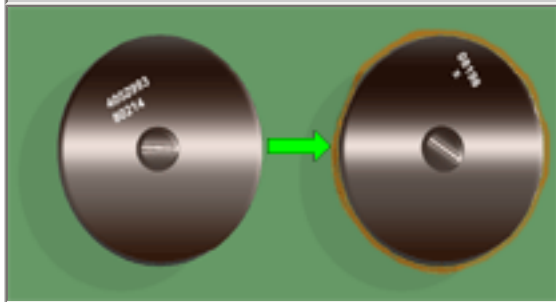
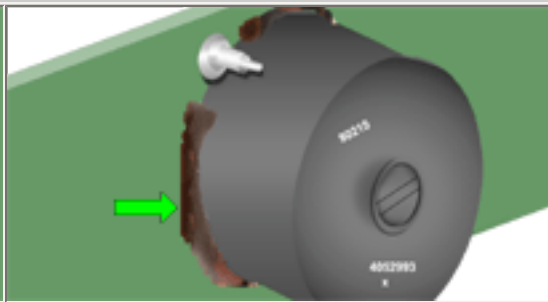
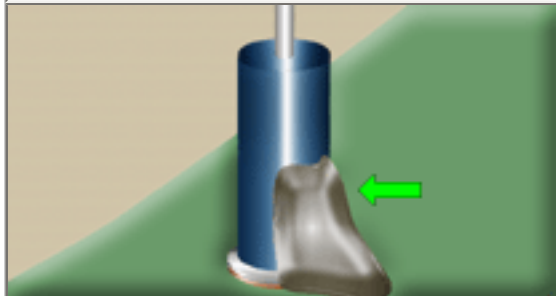
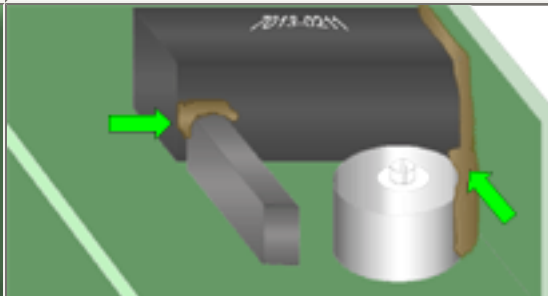
CONFORMAL COATING AND STAKING (BONDING) ADHESIVE BONDING/STAKING (cont.)	
	
<p style="text-align: center;">ACCEPTABLE TOROID STAKING-CONTINUOUS FILLET</p> <p>Staking of toroids and other large footprint components shall be sufficient to provide uniform support and prevent movement.</p> <p>NASA-STD-8739.1 [9.2.1]</p>	<p style="text-align: center;">ACCEPTABLE TOROID STAKING-DISCONTINUOUS FILLET</p> <p>The staking fillet may be discontinuous if the application of material will interfere with adjustable components, test points, or serviceable mechanical components. The staking shall be sufficient to provide uniform support.</p> <p>NASA-STD-8739.1 [9.2.1]</p>
	

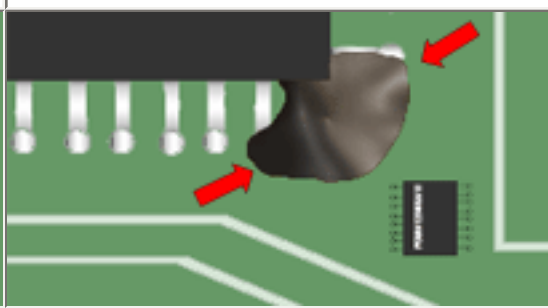
<p style="text-align: center;">ACCEPTABLE VERTICAL MOUNT AXIAL</p> <p>Staking wets and adheres to the component and the substrate for at least 50% of part length (L) and 25% of part circumference. Proper wetting and adhesion to the part and substrate is evident. NASA-STD-8739.1 [9.2.1]</p>	<p style="text-align: center;">ACCEPTABLE VIBRATION ISOLATION</p> <p>Staking materials applied for vibration isolation/support shall be applied per engineering documentation. NASA-STD-8739.1 [9.2.1]</p>
	
<p style="text-align: center;">UNACCEPTABLE BONDS IN STRESS RELIEF</p> <p>Staking material shall not negate stress relief of parts, enclose joints or part leads, or mechanically compromise the reliability of the hardware. NASA-STD-8739.1 [9.2.3]</p>	<p style="text-align: center;">UNACCEPTABLE BURIED COMPONENT LEAD</p> <p>Staking material shall not encapsulate a component's lead. NASA-STD-8739.1 [9.2.3.a]</p>

NASA WORKMANSHIP STANDARDS

 <p>NATIONAL AERONAUTICS AND SPACE ADMINISTRATION JOHNSON SPACE CENTER HOUSTON, TEXAS USA 77058</p>	Released: 04.05.2002	Revision:	Revision Date:
	Book: 8	Section: 8.02	Page: 4

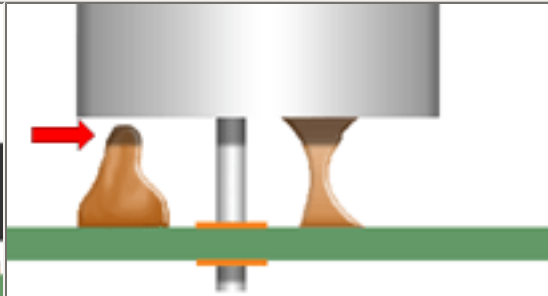
CONFORMAL COATING AND STAKING (BONDING) ADHESIVE BONDING/STAKING (cont.)	
	
<p style="text-align: center;">UNACCEPTABLE CONTACT WITH GLASS-BODIED PART</p> <p>Rigid staking material is in contact with the unsleeved area of a glass-bodied component. NASA-STD-8739.1 [9.2.3.c], [11.6.3.e]</p>	<p style="text-align: center;">UNACCEPTABLE IMPROPER WETTING</p> <p>Bonds do not show evidence of proper wetting and adhesion to the bottom and side of the component and the mounting surface. NASA-STD-8739.1 [9.2.1]</p>

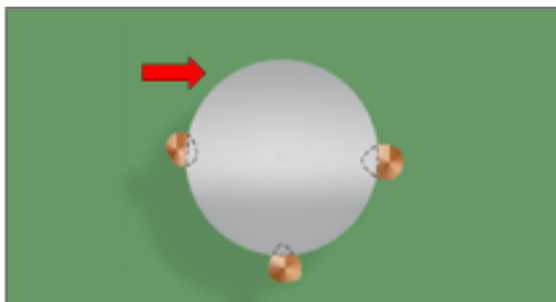
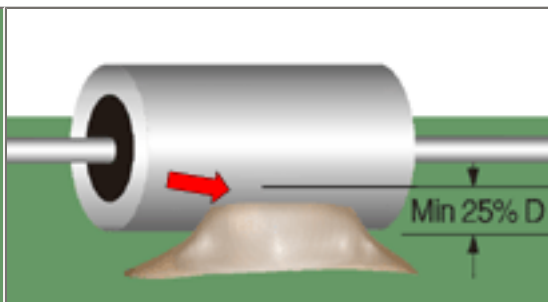
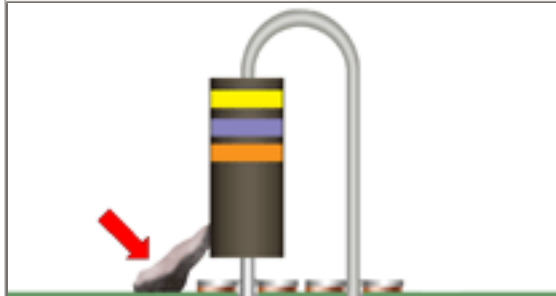
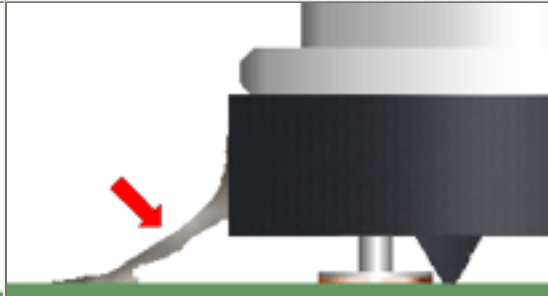
	
<p style="text-align: center;">UNACCEPTABLE INSUFFICIENT BONDS</p> <p>Bonds are less than specified in engineering documents and/or are less than a minimum of 4 equally spaced bonds for parts in excess of 7 gm (0.25 oz.) per lead.</p> <p>Best Workmanship Practice</p>	<p style="text-align: center;">UNACCEPTABLE INSUFFICIENT FILLET HORIZONTAL MOUNT</p> <p>Staking fillet height is less than 25% of the component diameter (D).</p> <p>Best Workmanship Practice</p>
	
<p style="text-align: center;">UNACCEPTABLE INSUFFICIENT FILLET VERTICAL MOUNT</p> <p>Staking extends upwards less than 50% of the component length (L).</p> <p>Best Workmanship Practice</p>	<p style="text-align: center;">UNACCEPTABLE INSUFFICIENT MECHANICAL SUPPORT</p> <p>The staking material forms too thin a column to provide good mechanical support.</p> <p>Best Workmanship Practice</p>

NASA WORKMANSHIP STANDARDS

 <p>NATIONAL AERONAUTICS AND SPACE ADMINISTRATION JOHNSON SPACE CENTER HOUSTON, TEXAS USA 77058</p>	Released: 04.05.2002	Revision:	Revision Date:
	Book: 8	Section: 8.01	Page: 5

**CONFORMAL COATING AND STAKING (BONDING)
ADHESIVE BONDING/STAKING (cont.)**

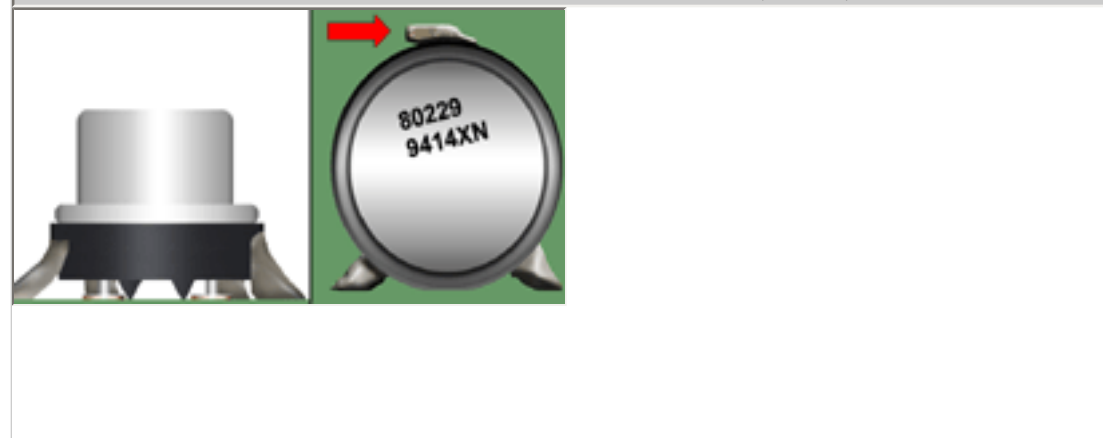

<p style="text-align: center;">UNACCEPTABLE</p> <p>INSUFFICIENT PERIPHERAL SUPPORT</p> <p>Less than 20% of the total periphery of the component is bonded.</p> <p>Best Workmanship Practice</p>

NASA WORKMANSHIP STANDARDS			
 <p>NATIONAL AERONAUTICS AND SPACE ADMINISTRATION JOHNSON SPACE CENTER HOUSTON, TEXAS USA 77058</p>	Released: 04.05.2002	Revision:	Revision Date:
	Book: 8	Section: 8.01	Page: 6



[Need a printed copy?](#)
(May take a while to load.)
Requires Adobe Reader.



[Need Adobe Reader?](#)
[Click here to download.](#)



[Questions? Suggestions?](#)

CONFORMAL COATING AND STAKING (BONDING)
CONFORMAL COATING

CONFORMAL COATING

Conformal coatings are intended to provide electrical insulation and environmental protection to the PWA, eliminating or minimizing any performance degradation caused by humidity, handling, debris and/or contamination.

Typical conformal coatings (i.e. Acrylic, Urethans, Epoxy, Silicone) can be applied in any standard vented environment by automatic/manual operations (i.e. spraying, brushing, dipping or a combination thereof). High performance coatings (i.e. Paraxylene) require a highly controlled environment, and are applied by Chemical Vapor Deposition (CVD).

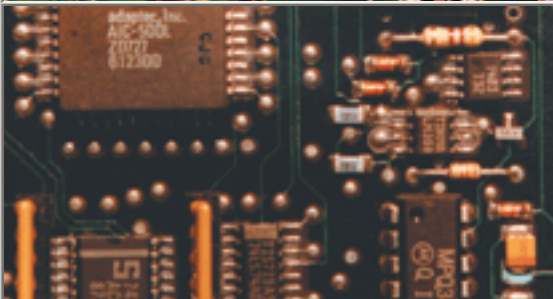
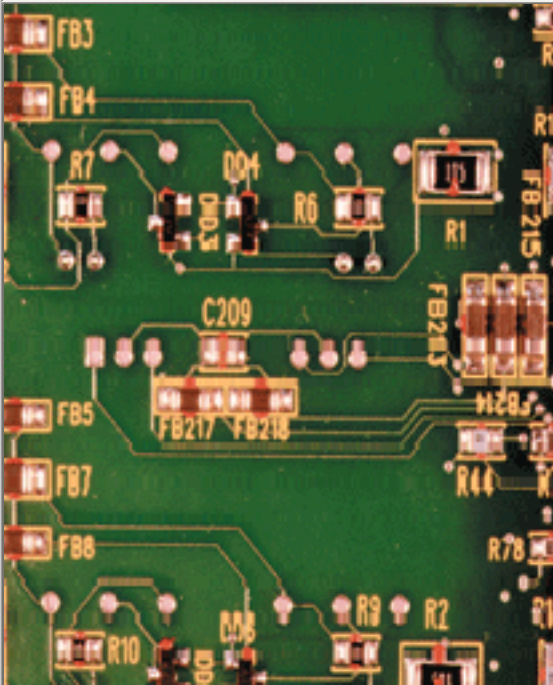

PREFERRED

Conformal coating covers all areas as specified on the engineering documentation. Coating exhibits uniform color, thickness, proper adhesion and is smooth, transparent and tack free. No bubbles, entrapped contaminants or particles, excessive fillets, runs, drips, etc. Identification markings are visible.

**ACCEPTABLE
BRUSH APPLICATIONS**

The conformal coating is evenly applied, without forming excessive fillets or thick areas. Minor brush marks are acceptable, provided minimum thickness is maintained.

[NASA-STD-8739.1 \[10.2.2.b\]](#)

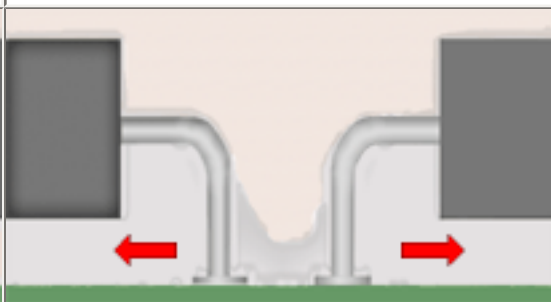
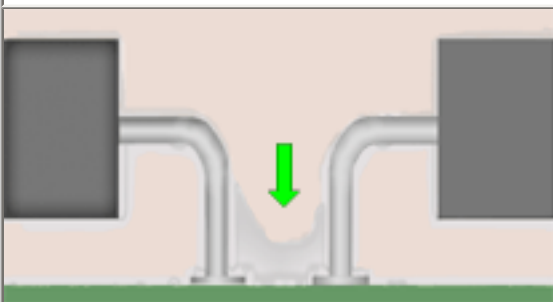

**ACCEPTABLE
BRIDGING**

Conformal coating may bridge adjacent part leads, provided stress relief is not negated.

[NASA-STD-8739.1 \[10.2.5.e\], \[11.8.2.j\]](#)



**UNACCEPTABLE
BRIDGING**

Coating shall not bridge between the bottom of ceramic-bodied DIPs or surface mount parts and the PWB, or between the part lead and the PWB, thereby negating stress relief.

[NASA-STD-8739.1 \[10.2.4.b\], \[11.8.3.b\]](#)

NASA WORKMANSHIP STANDARDS

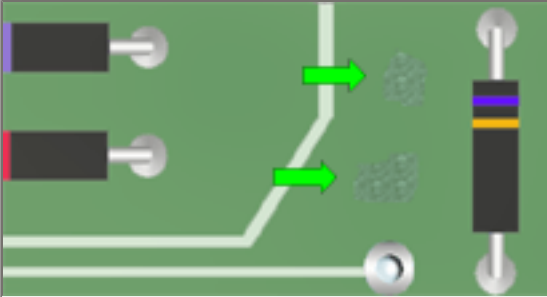
 NATIONAL AERONAUTICS AND SPACE ADMINISTRATION JOHNSON SPACE CENTER HOUSTON, TEXAS USA 77058	Released: 04.05.2002	Revision:	Revision Date:
	Book: 8	Section: 8.03	Page: 1

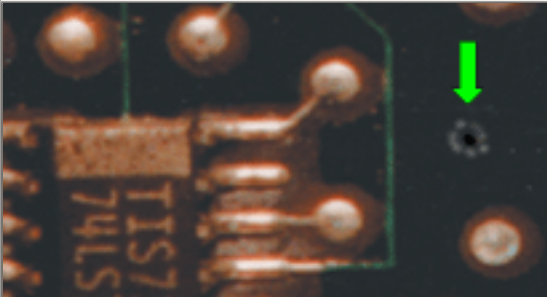
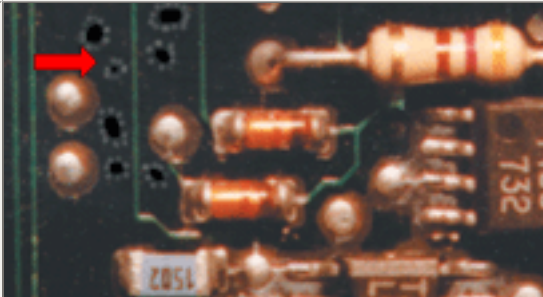
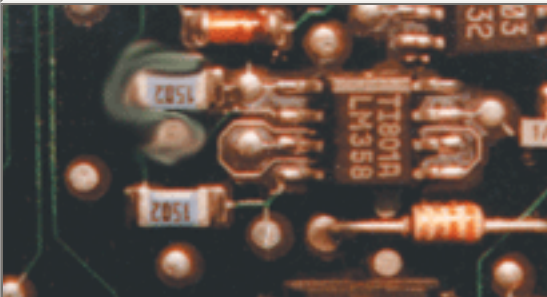
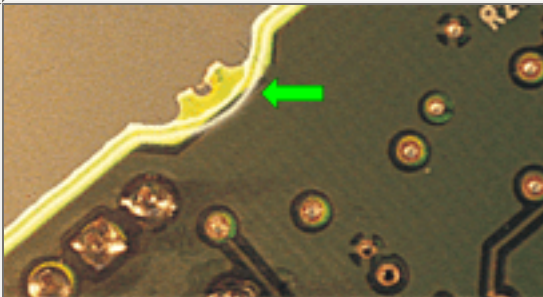
CONFORMAL COATING AND STAKING (BONDING) CONFORMAL COATING (cont.)	
	
<p style="text-align: center;">ACCEPTABLE BUBBLES</p> <p>Small bubbles, which do not bridge uncommon conductors, expose conductor surfaces, or exceed 0.76 mm (0.030 in.) in any dimension, are acceptable.</p> <p>NASA-STD-8739.1 [10.2.5]</p>	<p style="text-align: center;">UNACCEPTABLE BUBBLES</p> <p>Bubbles, which bridge uncommon conductors, expose conductor surfaces, or exceed 0.76 mm (0.030 in.) in any dimension, are not acceptable.</p> <p>NASA-STD-8739.1 [11.8.3.h], [11.8.3.i]</p>
	
<p style="text-align: center;">ACCEPTABLE FISHEYES</p> <p>Fisheyes shall not exceed 5% of the surface area.</p> <p>NASA-STD-8739.1 [10.2.5]</p>	<p style="text-align: center;">UNACCEPTABLE FISHEYES</p> <p>Fisheyes shall not exceed 5% of the surface area.</p> <p>NASA-STD-8739.1 [11.8.3.k]</p>
	

<p>ACCEPTABLE DIP APPLICATION</p> <p>The conformal coating exhibits complete coverage. Slightly uneven thickness, uneven filleting around parts, run contours, and edge loading are acceptable, provided minimum thickness is maintained.</p> <p>NASA-STD-8739.1 [10.2.2.c]</p>	<p>ACCEPTABLE PULL BACK</p> <p>Minor pull back from sharp points and edges is permissible, unless otherwise specified on engineering documentation.</p> <p>NASA-STD-8739.1 [10.2.5.b], [11.8.2.g]</p>
--	--

NASA WORKMANSHIP STANDARDS			
 <p>NATIONAL AERONAUTICS AND SPACE ADMINISTRATION JOHNSON SPACE CENTER HOUSTON, TEXAS USA 77058</p>	Released:	Revision:	Revision Date:
	04.05.2002		
	Book:	Section:	Page:
8	8.03	2	

**CONFORMAL COATING AND STAKING (BONDING)
CONFORMAL COATING (cont.)**

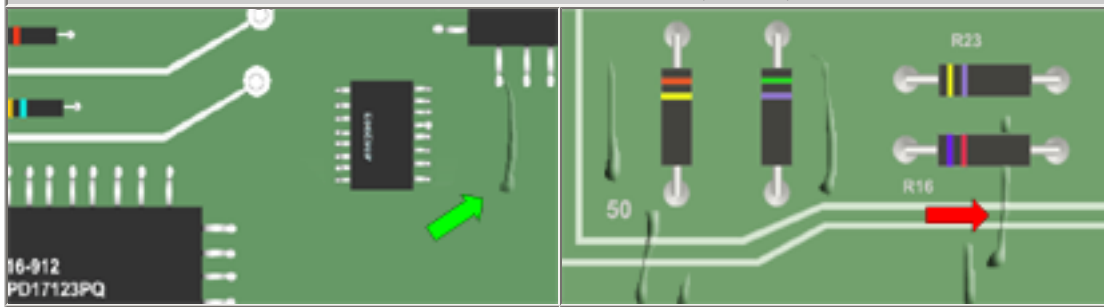

<p>ACCEPTABLE RUNS</p> <p>Runs shall not exceed 5% of the surface area.</p> <p>NASA-STD-8739.1 [10.2.5]</p>	<p>UNACCEPTABLE RUNS</p> <p>Runs shall not exceed 5% of the surface area.</p> <p>NASA-STD-8739.1 [11.8.3.k]</p>
--	--

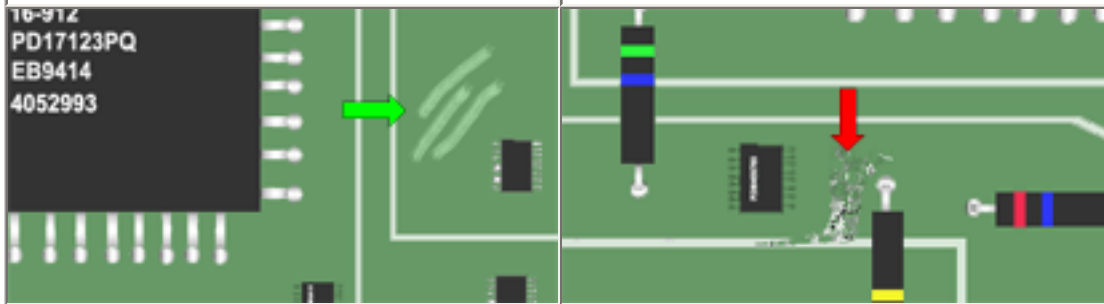

<p>ACCEPTABLE SCRATCHES</p> <p>Scratches, which so not expose conductive surfaces, or reduce the coating thickness below minimum thickness requirements, are acceptable.</p> <p>NASA-STD-8739.1 [10.2.5]</p>	<p>UNACCEPTABLE SCRATCHES/SCRAPES</p> <p>Scratches, which expose conductive surfaces, are not acceptable.</p> <p>NASA-STD-8739.1 [11.8.3.e]</p>
---	--



**ACCEPTABLE
SPRAY APPLICATION**

The conformal coating is evenly applied, exhibits uniform color, thickness, proper adhesion, and is smooth and tack free. No evidence of shadowing, orange peel or dusting.

[NASA-STD-8739.1 \[10.2.2.a\]](#)

**ACCEPTABLE
TERMINALS**

Terminals shall be conformally coated, including the wire insulation gap, unless it is a solder ball termination (i.e. a high-voltage termination). Minor pullback from shrp points and edges is acceptable.

[NASA-STD-8739.1 \[10.2.5.d\]](#)

NASA WORKMANSHIP STANDARDS



**NATIONAL AERONAUTICS AND
SPACE ADMINISTRATION**
JOHNSON SPACE CENTER
HOUSTON, TEXAS USA 77058

Released:
04.05.2002

Revision:

Revision Date:

Book:
8

Section:
8.03

Page:
3

**CONFORMAL COATING AND STAKING (BONDING)
CONFORMAL COATING (cont.)**



**ACCEPTABLE
ULTRAVIOLET (UV) FLUORESCENCE**

Conformal coating containing a fluorescent dye shall be examined under an ultraviolet (UV) source. The coating shall exhibit uniform fluorescence when exposed to an ultraviolet (UV) light source.

[NASA-STD-8739.1 \[11.9.2\]](#)

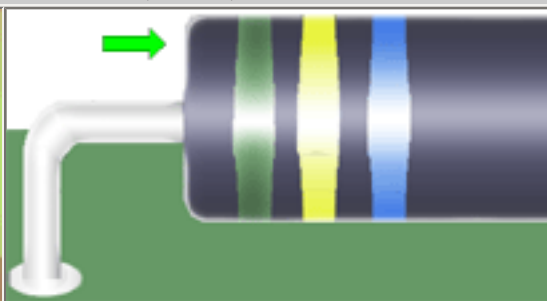



**ACCEPTABLE
VACUUM DEPOSITION**

Conformal coating covers all areas as specified on the engineering documentation. The coating is thin, of uniform thickness and fillet free.

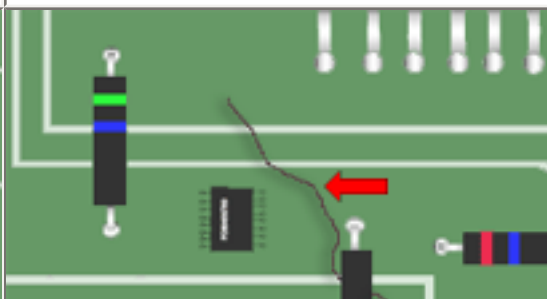
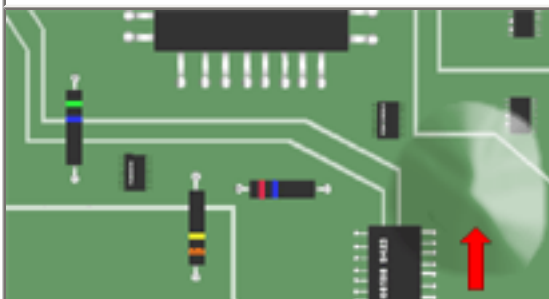
[NASA-STD-8739.1 \[10.2.2.d\]](#)

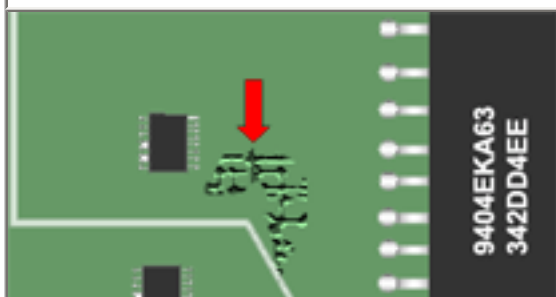
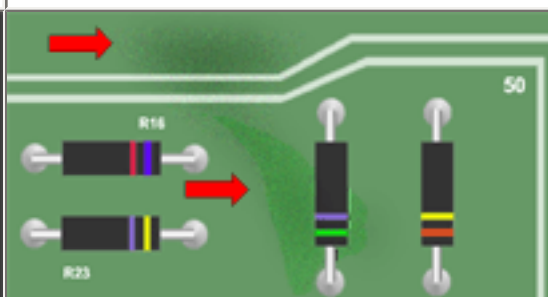

<p style="text-align: center;">UNACCEPTABLE BLISTERING</p> <p>Blistering is typically caused by improper preparation/priming or entrapped moisture or contaminants, and is cause for rejection.</p> <p>NASA-STD-8739.1 [11.8.3.e]</p>	<p style="text-align: center;">UNACCEPTABLE CONTAMINATION</p> <p>Contamination (i.e. flux, loose particles, foreign material, etc.) shall be cause for rejection.</p> <p>NASA-STD-8739.1 [10.2.5.c], [11.8.3.f]</p>
	
<p style="text-align: center;">UNACCEPTABLE CRACKING</p> <p>Cracking is typically caused by improper cure, excessive heat during cure, or excessive flexure of the substrate, and negate the environmental sealing properties of the coating.</p> <p>NASA-STD-8739.1 [11.8.3.e]</p>	<p style="text-align: center;">UNACCEPTABLE DISCOLORATION</p> <p>Conformal coating shall not exhibit discoloration (due to such things as excessive curing oven temperature, contamination, etc.).</p> <p>NASA-STD-8739.1 [10.2.5.f], [11.8.3.g]</p>

NASA WORKMANSHIP STANDARDS			
 <p>NATIONAL AERONAUTICS AND SPACE ADMINISTRATION JOHNSON SPACE CENTER HOUSTON, TEXAS USA 77058</p>	Released: 04.05.2002	Revision:	Revision Date:
	Book: 8	Section: 8.03	Page: 4

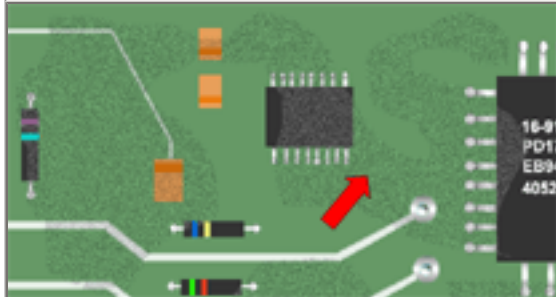
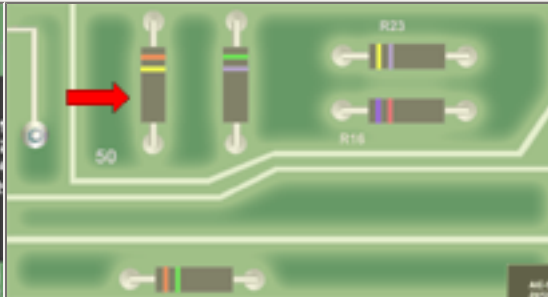
CONFORMAL COATING AND STAKING (BONDING) CONFORMAL COATING (cont.)	
	
<p style="text-align: center;">UNACCEPTABLE DUSTY/POWDERY FINISH</p> <p>A dusty or powdery finish is typically caused by over-spray from adjacent boards and/or improper spray distance.</p> <p>NASA-STD-8739.1 [10.2.5.a]</p>	<p style="text-align: center;">UNACCEPTABLE EXCESSIVE THICKNESS</p> <p>Conformal coatings shall completely encapsulate the components with a uniform thickness of material, and follow the contours of the PWA.</p> <p>NASA-STD-8739.1 [10.2.5.b]</p>



<p style="text-align: center;">UNACCEPTABLE FINGERPRINTS/INDENTATIONS</p> <p>Permanent fingerprints or indentations in the coating are an indicator of improper cure or handling.</p> <p>Best Workmanship Practice</p>	<p style="text-align: center;">UNACCEPTABLE HAZY/MILKY FINISH</p> <p>A hazy or milky appearance is an indicator of entrapped moisture, improperly mixed material, or material with an outdated shelf-life.</p> <p>NASA-STD-8739.1 [10.2.5.b], [11.8.3.a]</p>
<p style="text-align: center;">UNACCEPTABLE IMPROPER/MISSING COATING</p> <p>PWAs exhibiting coating that has not been applied to required areas, or coating on areas required to be free of coating, shall be rejectable.</p> <p>NASA-STD-8739.1 [10.2.5.b], [11.8.2.g]</p>	<p style="text-align: center;">UNACCEPTABLE LIFTING/MEASLING/PEELING</p> <p>Coating exhibiting excessive lifting, mealing or peeling may be an indicator of improper cleaning, priming, curing or excessive thickness. Any lifting on conductive areas is nonconforming.</p> <p>NASA-STD-8739.1 [11.8.3.j]</p>

NASA WORKMANSHIP STANDARDS

<p>NATIONAL AERONAUTICS AND SPACE ADMINISTRATION JOHNSON SPACE CENTER HOUSTON, TEXAS USA 77058</p>	Released: 04.05.2002	Revision:	Revision Date:
	Book: 8	Section: 8.03	Page: 5

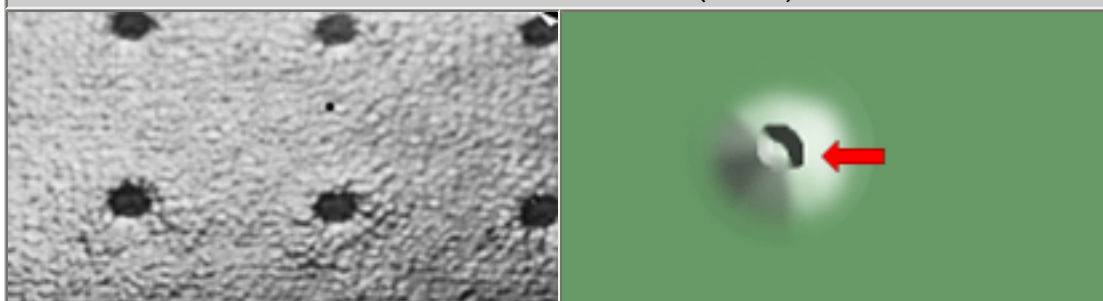
**CONFORMAL COATING AND STAKING (BONDING)
CONFORMAL COATING (cont.)**

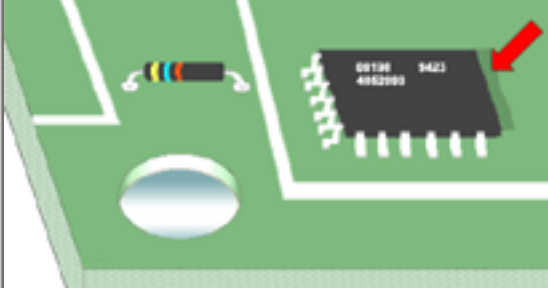

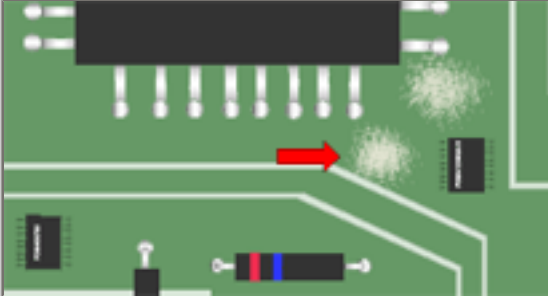
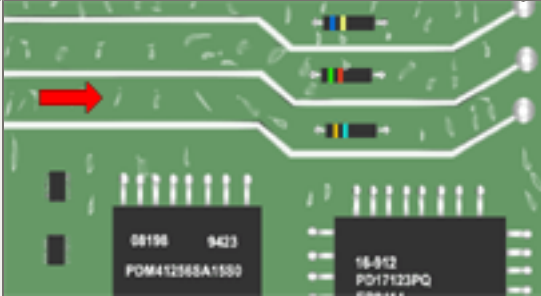
<p style="text-align: center;">UNACCEPTABLE ORANGE PEEL</p> <p>Uneven surface textures, such as orange peel, are an indicator of improper application, thickness and/or cure. NASA-STD-8739.1 [10.2.5.b]</p>	<p style="text-align: center;">UNACCEPTABLE PINHOLES</p> <p>Pinholes in the coating allow moisture and contaminants to potentially reduce the reliability of the PWA. NASA-STD-8739.1 [10.2.5.b], [11.8.3.e]</p>
 <p>An illustration of a green PCB with a resistor and a chip. A red arrow points to a textured, orange-peel surface on the coating.</p>	 <p>A photograph showing a hand pointing to a small hole in the coating on a PCB. A red arrow points to the pinhole.</p>
<p style="text-align: center;">UNACCEPTABLE SHADOWING</p> <p>Shadowing is caused by the incomplete/improper application of coating material during the spray process, and results in improper thickness or missing coverage. NASA-STD-8739.1 [10.2.2.a], [10.2.5.b]</p>	<p style="text-align: center;">UNACCEPTABLE SOFT SPOTS/TACKINESS</p> <p>Soft spots/tackiness (stickiness) indicate that the coating may not have been properly cured. Silicone coatings have a slightly rubbery feel, but are not sticky. NASA-STD-8739.1 [10.3.1], [11.8.3.d], [11.9.4]</p>
 <p>An illustration of a PCB with a resistor and a chip. A red arrow points to a shadowed area where the coating is missing or thin.</p>	 <p>An illustration of a PCB with a resistor and a chip. A red arrow points to a soft spot on the coating.</p>
<p style="text-align: center;">UNACCEPTABLE WHITISH SPOTS (MEASLING)</p> <p>Whitish spots are an indication of moisture/solvent contamination, and shall be rejectable. NASA-STD-8739.1 [11.8.3.e]</p>	<p style="text-align: center;">UNACCEPTABLE WRINKLING</p> <p>Wrinkling is an indicator of an improper/uneven cure or a reaction to unevaporated solvents on the laminate surface. NASA-STD-8739.1 [11.8.3.e]</p>

NASA WORKMANSHIP STANDARDS

 <p>NATIONAL AERONAUTICS AND SPACE ADMINISTRATION JOHNSON SPACE CENTER HOUSTON, TEXAS USA 77058</p>	Released: 04.05.2002	Revision:	Revision Date:
	Book: 8	Section: 8.03	Page: 6



[Need a printed copy?](#)
(May take a while to load.)
Requires Adobe Reader.

[Need Adobe Reader?](#)
[Click here to download.](#)

[Questions? Suggestions?](#)

POLYMERIC SYSTEMS
GENERAL REQUIREMENTS

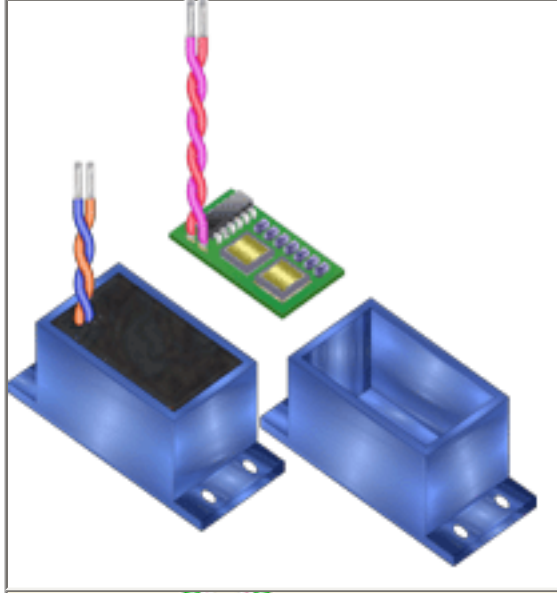

GENERAL REQUIREMENTS

Polymeric systems provide mechanical and cushioning support to components, improved thermal profile/thermal sinking and tamper-resistant, environmental packaging.

Encapsulation is a process in which electronic subassemblies (i.e. power supplies, amplifiers, hybrid circuits, etc.) are embedded in a polymer (i.e. silicon, epoxy gel) to produce a unitized, sealed assembly.

Underfill is a process in which a polymer (i.e. epoxy) is injected under an electronic component to improve thermal coefficient (tc) match and extend solder joint fatigue life.

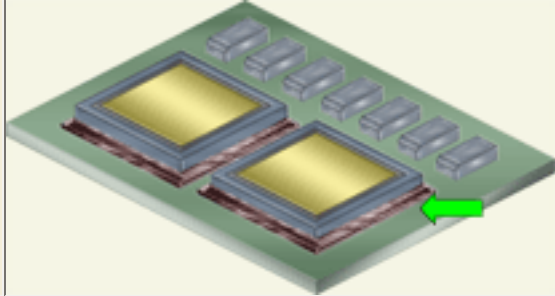
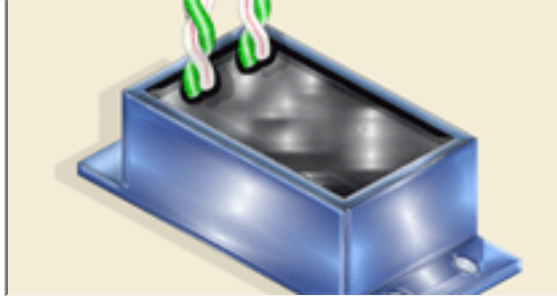

PREFERRED ENCAPSULANT

Material is fully cured, with a smooth, continuous surface extending over all embedded components, and exhibits filly, wetted, continuous contact fillets with protruding devices (wires cable, connector, etc.) and the enclosure wall. No bubbles, cavities, striation marks or spillage.

PREFERRED UNDERFILL

Material exhibits complete and uniform flow under the comonent body. Peripheral fillets are smooth and uniform, with a concave profile. No bubbles, cavities or spillage.

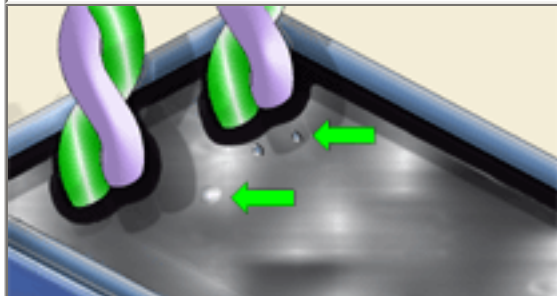

ACCEPTABLE BUBBLES/CAVITIES

Minor surface bubbles or cavities that do not extend to underlying components or conductive surfaces, are isolated, or bridge between conductors are acceptable.

[Best Workmanship Practice](#)

UNACCEPTABLE BUBBLES/CAVITIES

Bubbles or cavities that bridge conductors are unacceptable.

[Best Workmanship Practice](#)

NASA WORKMANSHIP STANDARDS



Released: 04.05.2002	Revision:	Revision Date:
-------------------------	-----------	----------------

	Book: 9	Section: 9.01	Page: 1
--	------------	------------------	------------

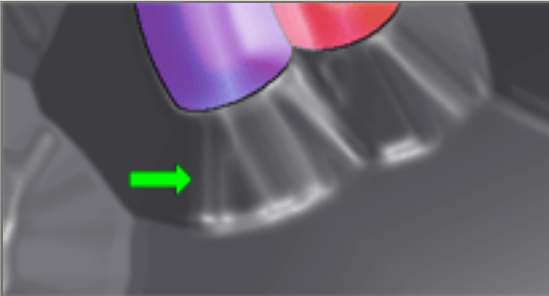
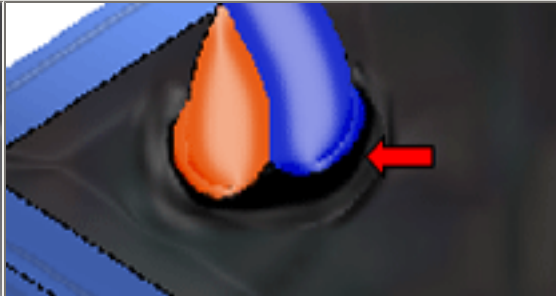
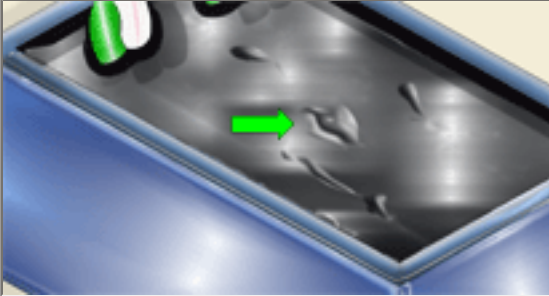
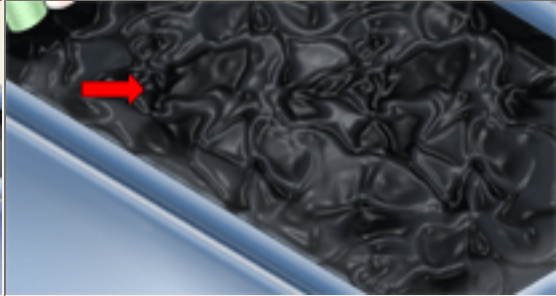
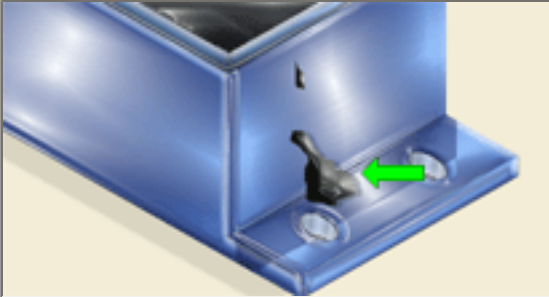
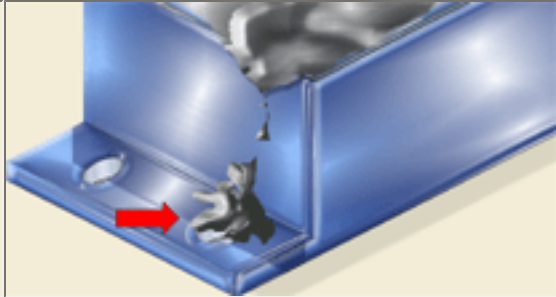
POLYMERIC SYSTEMS GENERAL REQUIREMENTS (cont.)	
	
<p>ACCEPTABLE ENCAPSULANT FILLETS</p> <p>Assembly exhibits proper fill, with complete fillets extending a minimum of two (2) largest wire diameters above the encapsulant surface.</p> <p>Best Workmanship Practice</p>	<p>UNACCEPTABLE MISSING FILLETS</p> <p>Assembly does not exhibit required fillets extending two (2) largest wire diameters above the encapsulant surface.</p> <p>Best Workmanship Practice</p>
	
<p>ACCEPTABLE PROFILE/FINISH</p> <p>A rough profile/finish is caused by gel set (pre-cure) of the material, before the material has had sufficient time to smoothly settle and flow. Minor roughness that does not interfere with the form, fit, or function of the device is acceptable.</p> <p>Best Workmanship Practice</p>	<p>UNACCEPTABLE PROFILE/FINISH</p> <p>Excessive peaks, crests or folds indicate that the material was worked beyond its pot life. Assemblies typically exhibit improper adhesion, entrapped voids, etc. and shall be rejected.</p> <p>Best Workmanship Practice</p>
	

<p>ACCEPTABLE SPILLAGE</p> <p>Minor spillage that does not interfere with the form, fit or function of the device is acceptable.</p> <p>Best Workmanship Practice</p>	<p>UNACCEPTABLE EXCESSIVE FILL/SPILLAGE</p> <p>Excessive fill or spillage that interferes with the form, fit or function shall be rejectable.</p> <p>Best Workmanship Practice</p>
--	---

NASA WORKMANSHIP STANDARDS			
 <p>NATIONAL AERONAUTICS AND SPACE ADMINISTRATION JOHNSON SPACE CENTER HOUSTON, TEXAS USA 77058</p>	Released:	Revision:	Revision Date:
	04.05.2002		
	Book:	Section:	Page:
9	9.01	2	

**POLYMERIC SYSTEMS
GENERAL REQUIREMENTS (cont.)**

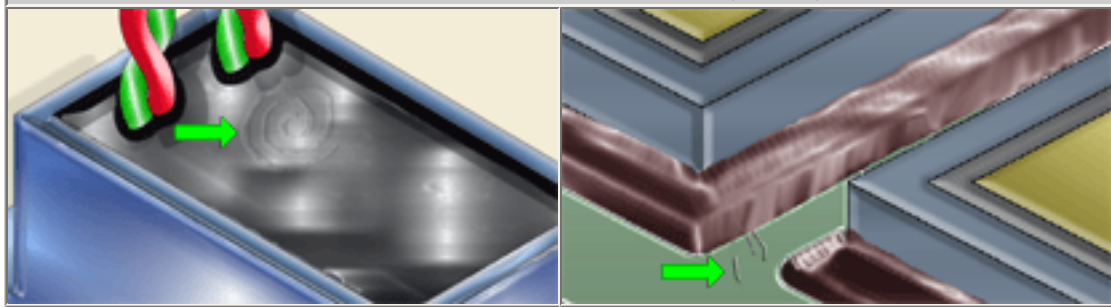

**ACCEPTABLE
STRIATION/FLOW MARKS**

Striation/flow marks are an indicator of material flow during fill/pour, and are acceptable, provided no other defects are evident and the material meets wetting, cure and hardness requirements.

[Best Workmanship Practice](#)

**ACCEPTABLE
STRINGING**

Minor stringing is acceptable, provided the deposit is completely adhered, does not contact exposed conductive circuits, component leads, jumpers or glass-bodied components, and is not subject to flexure.

[Best Workmanship Practice](#)

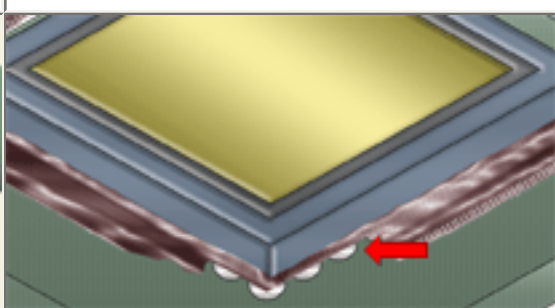
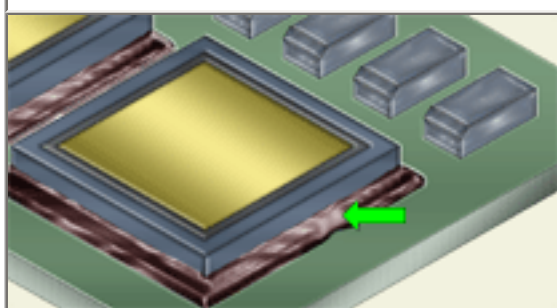

**ACCEPTABLE
UNDERFILL FILLETS**

Assembly exhibits proper fill, with complete positive fillets extending around the periphery of the device body.

[Best Workmanship Practice](#)

**UNACCEPTABLE
INCOMPLETE/PARTIAL UNDERFILL**

Incomplete or partial underfill can result in solder joint failure and incorrect/uneven thermal profile.

[Best Workmanship Practice](#)

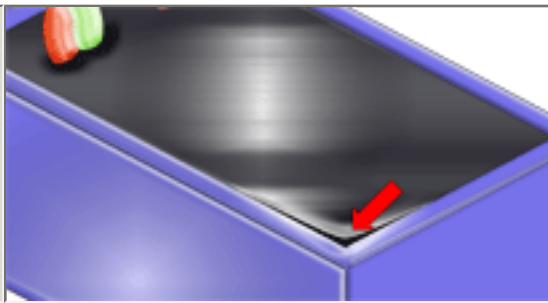
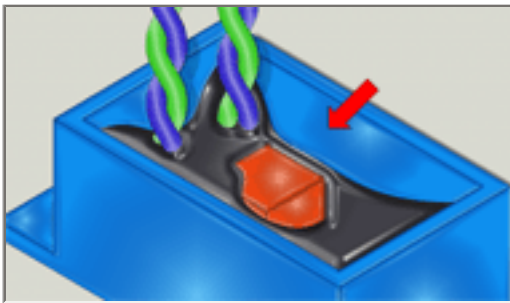

UNACCEPTABLE
EXPOSED CIRCUITRY/COMPONENTS
 Assemblies exhibiting exposed circuitry, components, conductive surfaces shall be rejected.
[Best Workmanship Practice](#)

UNACCEPTABLE
PULL-AWAY/PARTING
 Assemblies exhibiting pull-away of the encapsulant shall be rejected. Pull-away is caused by improper adhesion, improper wetting or excessive shrinkage.
[Best Workmanship Practice](#)

NASA WORKMANSHIP STANDARDS			
 NATIONAL AERONAUTICS AND SPACE ADMINISTRATION JOHNSON SPACE CENTER HOUSTON, TEXAS USA 77058	Released: 04.05.2002	Revision:	Revision Date:
	Book: 9	Section: 9.01	Page: 3

POLYMERIC SYSTEMS
 GENERAL REQUIREMENTS (cont.)

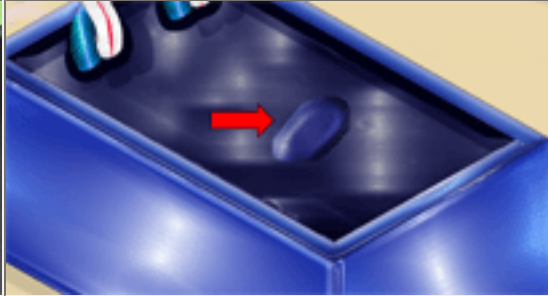
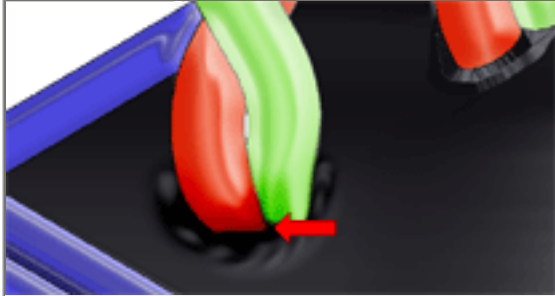

UNACCEPTABLE
RECESSED FILLETS
 Recessed (negative) fillets indicate improper wetting/non-wetting and shall be grounds for rejection.
[Best Workmanship Practice](#)

UNACCEPTABLE
TACKINESS
 Tackiness indicates an improper/incomplete cure. Tackiness usually manifests itself in the generation of residual fingerprint reliefs (permanent marks) and/or depressions, following light touching of the surface.
[Best Workmanship Practice](#)

NASA WORKMANSHIP STANDARDS			
 NATIONAL AERONAUTICS AND SPACE ADMINISTRATION JOHNSON SPACE CENTER HOUSTON, TEXAS USA 77058	Released: 04.05.2002	Revision:	Revision Date:
	Book: 9	Section: 9.01	Page: 4



[Need a printed copy?](#)
(May take a while to load.)
Requires Adobe Reader.





[Need Adobe Reader?](#)
[Click here to download.](#)

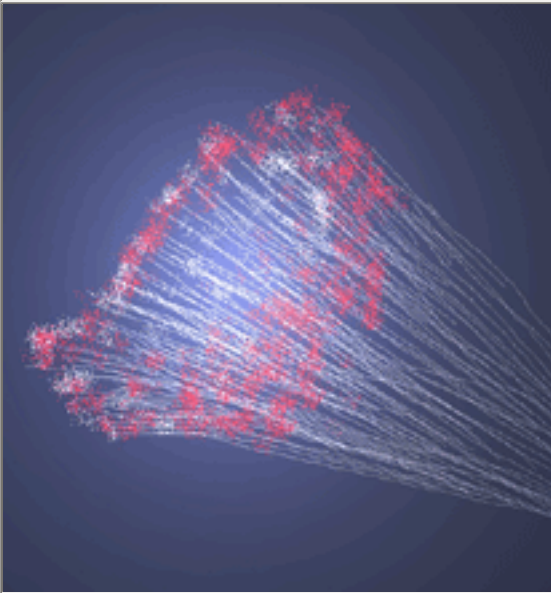
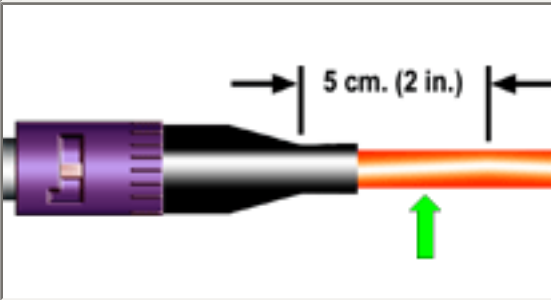
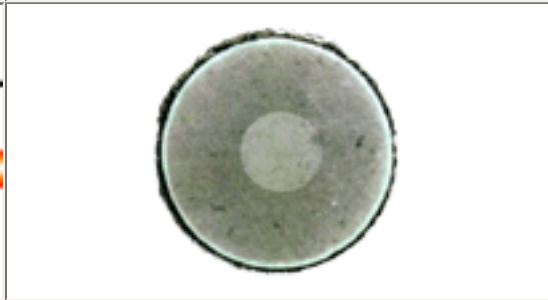
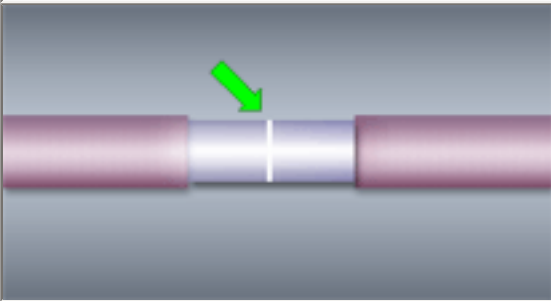
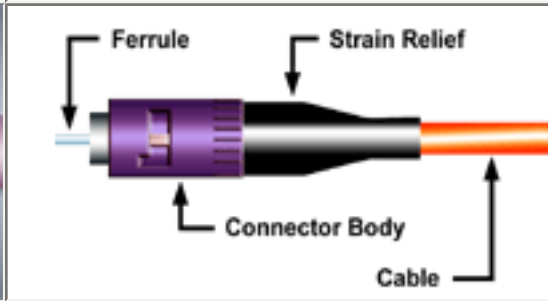

[Questions? Suggestions?](#)

FIBER OPTICS GENERAL REQUIREMENTS	
	<p style="text-align: center;"><u>FIBER OPTICS</u></p> <p>The term Fiber Optics (FO) is used to describe a technology which is based upon the use of a filament-shaped optical waveguide, made of a dielectric material (plastic or glass) having controlled optical reflection and refraction properties, to transmit information as light pulses rather than electrical pulses.</p> <p>Fiber Optics has benefits that the traditional copper-based system does not, including low weight, electromagnetic noise immunity and extremely high transmission speeds.</p>
	
<p style="text-align: center;">PREFERRED AXIAL ALIGNMENT</p> <p>Axial alignment of the cable to the connector shall be maintained within 5 cm (2 in.) of the entry/exit from the connector body.</p> <p>NASA-STD-8739.5 [10.2.7.h]</p>	<p style="text-align: center;">PREFERRED BARE FIBER AND FACE</p> <p>End face is smooth and free from cracks, scratches, edge chips, hackles, pits and/or other surface or sub-surface anomalies. The core is clearly discernable. Cleave angle is less than 2 degrees from perpendicular to the fiber axis.</p> <p>NASA-STD-8739.5 [App. A]</p>
	
<p style="text-align: center;">PREFERRED CHEMICAL SPLICE</p> <p>The fiber endfaces are perfectly aligned and in contact with each other. No bubbles or contamination.</p> <p>Note: Chemical splices are allowed for the temporary joining of fiber optics (i.e. test) only.</p> <p>NASA-STD-8739.5 [9.2.2.c]</p>	<p style="text-align: center;">PREFERRED CONNECTOR/CABLE CONFIGURATION</p> <p>Connector is properly assembled, clean and damage-free. Strain-relief is properly installed, straight, tight and damage-free. Axial alignment of the cable to the connector is maintained within 5 cm (2 in.) of the exit from the connector body.</p> <p>NASA-STD-8739.5 [11.3]</p>
<p>NASA WORKMANSHIP STANDARDS</p>	

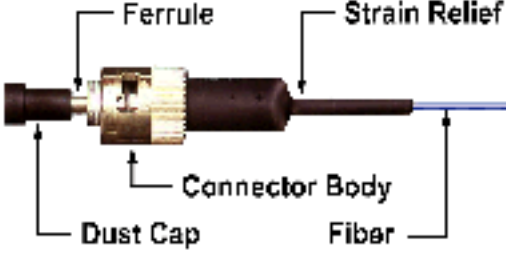
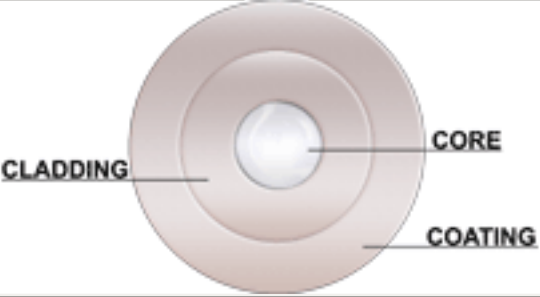
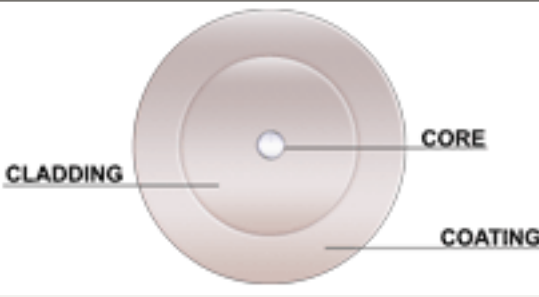
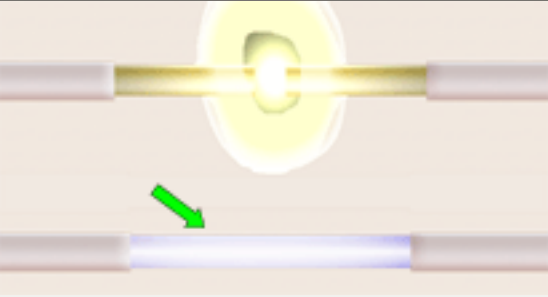
 NATIONAL AERONAUTICS AND SPACE ADMINISTRATION JOHNSON SPACE CENTER HOUSTON, TEXAS USA 77058	Released: 04.05.2002	Revision:	Revision Date:
	Book: 10	Section: 10.01	Page: 1

FIBER OPTICS GENERAL REQUIREMENTS (cont.)	
	
<p>PREFERRED CONNECTOR/FIBER CONFIGURATION</p> <p>The connector is properly assembled, clean and damage-free. The connector and fiber strain-relief device(s) are properly installed, straight, tight and damage-free. Axial alignment of the fiber to the connector is maintained within specifications.</p> <p>NASA-STD-8739.5 [11.3]</p>	<p>PREFERRED ENDFACE (MULTI-MODE)</p> <p>The endface is clean and free from cracks, scratches, edge chips, hackles, pits and other anomalies. The fiber is concentric in the ferrule, and the epoxy ring is even. Ferrule and connector are damage-free.</p> <p>NASA-STD-8739.5 [11.3.1.c]</p>
	
<p>PREFERRED ENDFACE (SINGLE-MODE)</p> <p>The endface is clean and free from cracks, scratches, edge chips, hackles, pits and other anomalies. The fiber is concentric in the ferrule, and the epoxy ring is even. Ferrule and connector are damage-free.</p> <p>NASA-STD-8739.5 [11.3.1.c]</p>	<p>PREFERRED FUSION SPLICE</p> <p>The splice is perfectly aligned. Fusion zone is of uniform diameter, with no bubbles, contamination or boundary layer evident. Splice closure is properly installed.</p> <p>NASA-STD-8739.5 [9.2.2.a]</p>
	

<p>PREFERRED MECHANICAL SPLICE</p> <p>The fibers are properly inserted, aligned and the endfaces are in contact with each other. Splice housing is properly assembled, and strain relief features are set. Mechanical splices are not for spaceflight applications.</p> <p>NASA-STD-8739.5 [9.2.2.b]</p>	<p>PREFERRED SPLICE CLOSURE</p> <p>Splices shall be protected. If an enclosure cannot be used for a specific application, engineering documentation shall provide for other means of protection.</p> <p>NASA-STD-8739.5 [9.2.3.b]</p>
---	--

NASA WORKMANSHIP STANDARDS			
 <p>NATIONAL AERONAUTICS AND SPACE ADMINISTRATION JOHNSON SPACE CENTER HOUSTON, TEXAS USA 77058</p>	Released:	Revision:	Revision Date:
	04.05.2002		
	Book:	Section:	Page:
	10	10.01	2

**FIBER OPTICS
GENERAL REQUIREMENTS (cont.)**

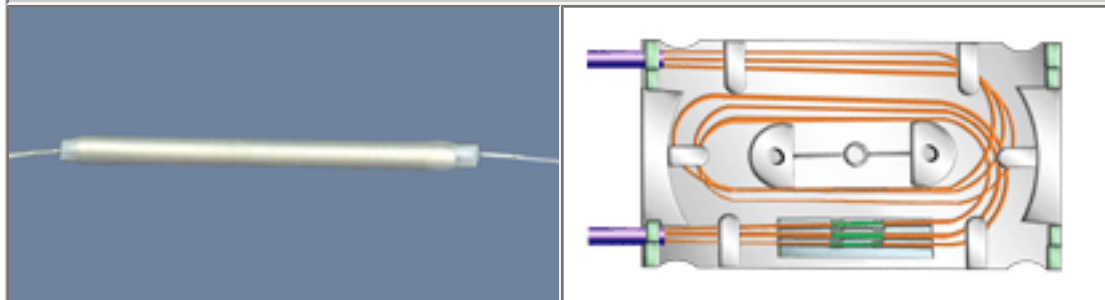

<p>PREFERRED SPLICE LOCATION</p> <p>Splices shall not be located in flexure areas of the cable except when a splice is recoated and re-jacketed in accordance with the manufacturer's specifications.</p> <p>NASA-STD-8739.5 [9.2.3.a]</p>	<p>PREFERRED SPLICE TRAY</p> <p>Splices shall be neatly organized and marked. Service loops shall be adequate, with bend radii within specifications.</p> <p>NASA-STD-8739.5 [9.3.9]</p>
---	---

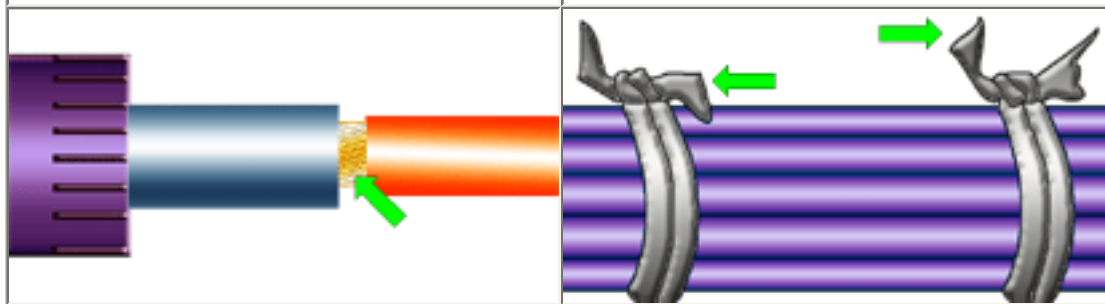

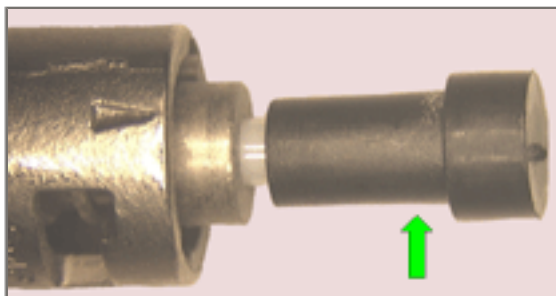
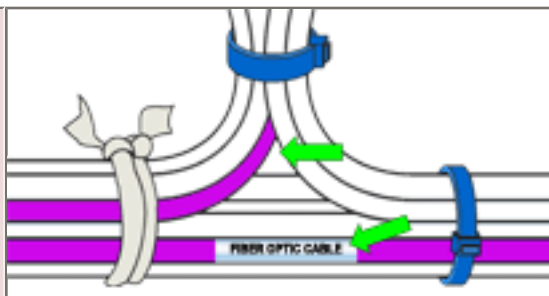

<p>PREFERRED STRENGTH MEMBER</p> <p>Strength members shall be secured to prevent mechanical stress on the fiber.</p> <p>NASA-STD-8739.5 [9.2.3.c]</p>	<p>PREFERRED TIE DOWNS</p> <p>Optical fibers and cables shall be tied down per engineering documentation. Ties shall not pinch, deform or stress the fiber.</p> <p>NASA-STD-8739.5 [11.4.3], [12.2.3], [12.3.4]</p>
--	--

	
<p style="text-align: center;">MANDATORY DUST CAP</p> <p>Dust caps shall be installed on all connectors when not in use. Vinyl dust caps shall not be used. NASA-STD-8739.5 [12.2.4], [12.3.5]</p>	<p style="text-align: center;">MANDATORY IDENTIFICATION</p> <p>Fiber optic cables shall be identified in such a way to distinguish these cables from wire or coaxial cable. Identification methods typically used are color-coding, labeling/markings, etc. NASA-STD-8739.5 [10.2.2]</p>

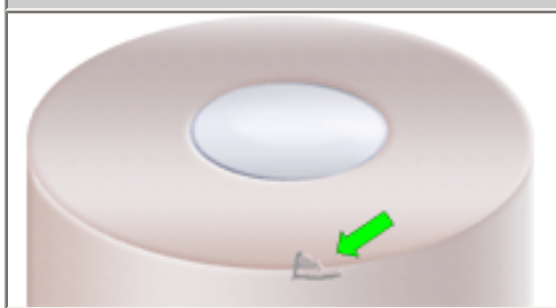
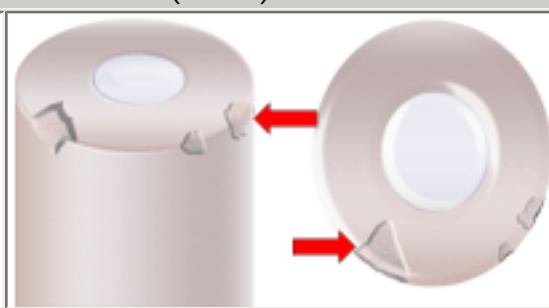
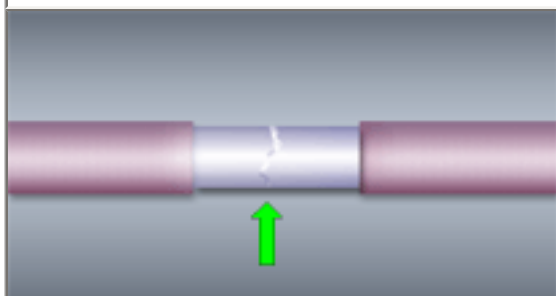
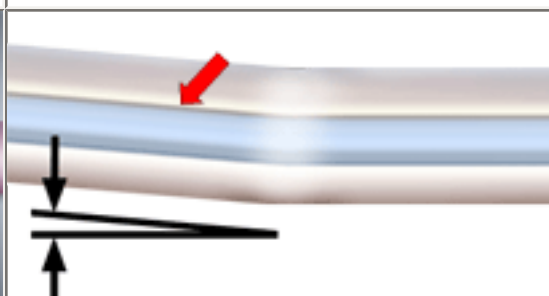
NASA WORKMANSHIP STANDARDS				
	<p>NATIONAL AERONAUTICS AND SPACE ADMINISTRATION</p> <p>JOHNSON SPACE CENTER HOUSTON, TEXAS USA 77058</p>	Released: 04.05.2002	Revision: 	Revision Date:
		Book: 10	Section: 10.01	Page: 3

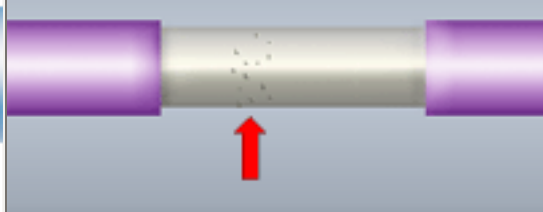
FIBER OPTICS GENERAL REQUIREMENTS (cont.)	
	
<p>ACCEPTABLE ENDFACE ANOMALIES EDGE CHIPS</p> <p>Edge chips are acceptable if chip maximum dimension is $\leq 3\%$ of fiber diameter and there are less than 3 chips total. May be fixable by repolishing if connectorized. NASA-STD-8739.5 [10.2.7.e]</p>	<p>UNACCEPTABLE ENDFACE ANOMALIES EDGE CHIPS</p> <p>Unacceptable if chip maximum dimension is $>3\%$ of fiber diameter and/or there are more than 3 chips. Reject and releave for splice termination. May be fixable by repolishing if connectorized. NASA-STD-8739.5 [10.2.7.e]</p>
	

<p style="text-align: center;">ACCEPTABLE FUSION SPLICES</p> <p>Mating fibers are properly aligned, but fused section is slightly distorted. No bubbles or boundary layer/diffraction zone. Optical loss is within engineering requirements.</p> <p>Best Workmanship Practice</p>	<p style="text-align: center;">UNACCEPTABLE FUSION SPLICES ANGULAR MISALIGNMENT</p> <p>Caused by poor cleaves and/or misalignment of the mating fiber ends. High attenuation and poor mechanical properties. Scrap and reterminate.</p> <p>Best Workmanship Practice</p>
	
<p style="text-align: center;">UNACCEPTABLE FUSION SPLICES BOUNDARY LAYER/DIFFRACTION ZONE</p> <p>A boundary layer or diffraction zone in a fusion splice is an indicator of an incomplete fusion process, improper cleave and/or contamination. Scrap and reterminate.</p> <p>Best Workmanship Practice</p>	<p style="text-align: center;">UNACCEPTABLE FUSION SPLICES BUBBLES</p> <p>Bubbles in a fusion splice are an indicator of an incomplete fusion process, improper cleave, and/or contamination. Scrap and reterminate.</p> <p>Best Workmanship Practice</p>

NASA WORKMANSHIP STANDARDS				
	<p>NATIONAL AERONAUTICS AND SPACE ADMINISTRATION JOHNSON SPACE CENTER HOUSTON, TEXAS USA 77058</p>	<p>Released: 04.05.2002</p>	<p>Revision:</p>	<p>Revision Date:</p>
		<p>Book: 10</p>	<p>Section: 10.01</p>	<p>Page: 4</p>

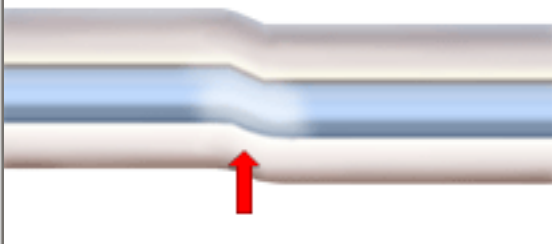
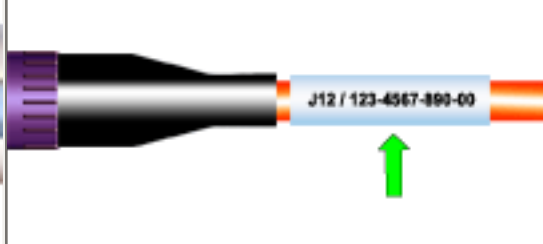
FIBER OPTICS GENERAL REQUIREMENTS (cont.)	
	
<p style="text-align: center;">UNACCEPTABLE FUSION SPLICES LATERAL OFFSET</p> <p>Caused by a lateral misalignment during the fusion process. Very high attenuation and poor mechanical properties. Scrap and reterminate.</p> <p>Best Workmanship Practice</p>	<p style="text-align: center;">ACCEPTABLE MARKINGS</p> <p>Cable connectors shall be permanently marked with mating connector designation within 15 cm (6 in.) of the connector body, or as per engineering documentation.</p> <p>NASA-STD-8739.5 [10.2.3]</p>

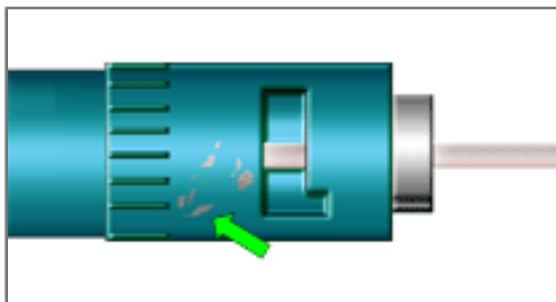
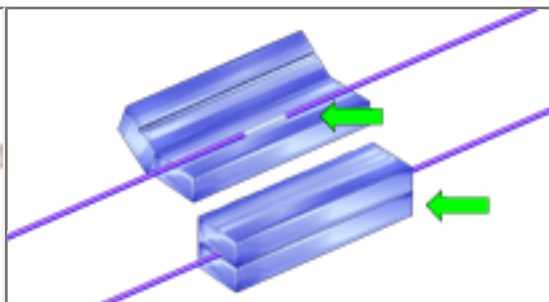
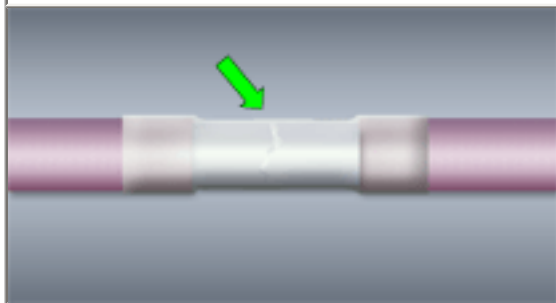
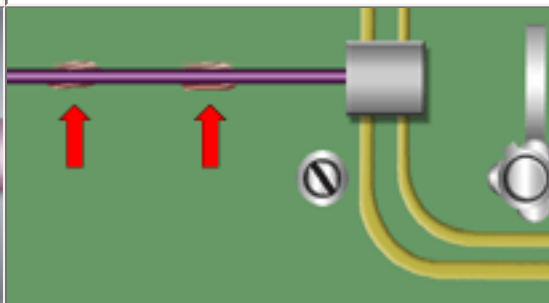

	
<p style="text-align: center;">ACCEPTABLE SCUFF MARKS</p> <p>Minor scuff marks on the connector body, and/or cable jacket are acceptable, provided the damage does not impact form, fit or function. Scuffing on the ferrule is an indicator of improper handling or excessive use.</p> <p>Best Workmanship Practice</p>	<p style="text-align: center;">ACCEPTABLE SPLICE PROTECTOR BUTTERFLY</p> <p>Splice closure is properly installed, and strain relief features are set.</p> <p>NASA-STD-8739.5 [9.2.2.a]</p>
	
<p style="text-align: center;">ACCEPTABLE SPLICE PROTECTOR HEAT SHRINK</p> <p>Splice closure is properly located. Shrinkage is uniform and strain relief features are set. No evidence of scorching, burning or melting.</p> <p>NASA-STD-8739.5 [9.2.2.a]</p>	<p style="text-align: center;">UNACCEPTABLE CONFORMAL COATING/STAKING</p> <p>Conformal coating or staking shall not be applied to optical fiber unless specifically required in the engineering documentation.</p> <p>NASA-STD-8739.5 [11.4.5]</p>

NASA WORKMANSHIP STANDARDS

 <p>NATIONAL AERONAUTICS AND SPACE ADMINISTRATION JOHNSON SPACE CENTER HOUSTON, TEXAS USA 77058</p>	<p>Released: 04.05.2002</p>	<p>Revision:</p>	<p>Revision Date:</p>
	<p>Book: 10</p>	<p>Section: 10.01</p>	<p>Page: 5</p>

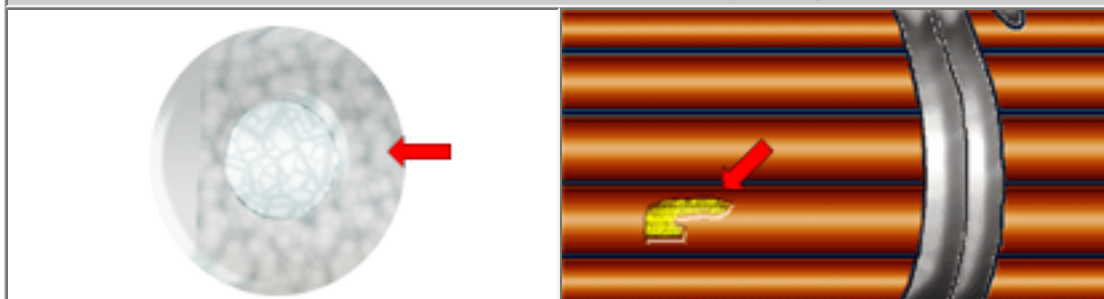
**FIBER OPTICS
GENERAL REQUIREMENTS (cont.)**

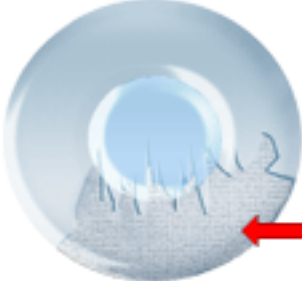

<p style="text-align: center;">UNACCEPTABLE CONTAMINATION</p> <p>Contamination is the primary cause of splicing and connectorization problems. Fingerprints and cleaning residue on the endface can significantly degrade signal quality.</p> <p>Best Workmanship Practice</p>	<p style="text-align: center;">UNACCEPTABLE DAMAGE</p> <p>Damage to the buffer, outer jacket, or other cable components in excess of engineering specification shall be cause for rejection.</p> <p>Best Workmanship Practice</p>
	
<p style="text-align: center;">UNACCEPTABLE ENDFACE ANOMALIES BREAKDOWN/ROLLOFF</p> <p>A surface irregularity characterized by an angular shearing of a portion of the endface. Defect is non-repairable. The fiber/assembly shall be reterminated or scrapped.</p> <p>Best Workmanship Practice</p>	<p style="text-align: center;">UNACCEPTABLE ENDFACE ANOMALIES CONCAVE</p> <p>A surface irregularity caused by excessive polishing or an improper cleave. Defect is non-repairable. The assembly/ fiber shall be reterminated or scrapped.</p> <p>Best Workmanship Practice</p>
	
<p style="text-align: center;">UNACCEPTABLE ENDFACE ANOMALIES CONVEX</p> <p>A surface irregularity caused by incomplete polishing or an improper cleave. Reject and recleave for splice termination. May be fixable by repolishing if connectorized.</p> <p>Best Workmanship Practice</p>	<p style="text-align: center;">UNACCEPTABLE ENDFACE ANOMALIES HACKLE/MIST</p> <p>A surface irregularity characterized by a jagged, rippled or stepped break in the fiber face. Reject and recleave for splice termination. May be fixable by repolishing if connectorized.</p> <p>NASA-STD-8739.5 [9.2.1]</p>

NASA WORKMANSHIP STANDARDS			
 <p>NATIONAL AERONAUTICS AND SPACE ADMINISTRATION JOHNSON SPACE CENTER HOUSTON, TEXAS USA 77058</p>	Released: 04.05.2002	Revision:	Revision Date:
	Book: 10	Section: 10.01	Page: 6

FIBER OPTICS
GENERAL REQUIREMENTS (cont.)

	
<p style="text-align: center;">UNACCEPTABLE ENDFACE ANOMALIES LIP</p> <p>A surface irregularity characterized by a raised fillet in the fiber edge. Reject and releave for splice termination. May be fixable by repolishing if connectorized.</p> <p>Best Workmanship Practice</p>	<p style="text-align: center;">UNACCEPTABLE ENDFACE ANOMALIES NECKING</p> <p>Necking is the drawing (pulling) of the optical fiber to a smaller diameter during stripping. The fiber shall be trimmed and restripped.</p> <p>Best Workmanship Practice</p>
	
<p style="text-align: center;">UNACCEPTABLE ENDFACE ANOMALIES NOTCH</p> <p>A surface irregularity characterized by a radial chip in the fiber edge. Reject and releave for splice termination. May be fixable by repolishing if connectorized.</p> <p>Best Workmanship Practice</p>	<p style="text-align: center;">UNACCEPTABLE ENDFACE ANOMALIES SCRATCHES</p> <p>Reject and releave for splice termination. May be fixable by repolishing if connectorized.</p> <p>NASA-STD-8739.5 [10.2.7.e]</p>
	
<p style="text-align: center;">UNACCEPTABLE ENDFACE ANOMALIES SHATTERED</p> <p>A surface irregularity characterized by radial cracks in the core or cladding. Defect is non-repairable. The fiber/ assembly shall be reterminated or scrapped.</p> <p>Best Workmanship Practice</p>	<p style="text-align: center;">UNACCEPTABLE ENDFACE ANOMALIES SPIRAL</p> <p>A surface irregularity characterized by a circular (screw-shaped) cleave. Defect is non-repairable. The fiber/ assembly shall be reterminated or scrapped.</p> <p>Best Workmanship Practice</p>

NASA WORKMANSHIP STANDARDS

 <p>NATIONAL AERONAUTICS AND SPACE ADMINISTRATION JOHNSON SPACE CENTER HOUSTON, TEXAS USA 77058</p>	<p>Released: 04.05.2002</p>	<p>Revision:</p>	<p>Revision Date:</p>
	<p>Book: 10</p>	<p>Section: 10.01</p>	<p>Page: 7</p>

FIBER OPTICS GENERAL REQUIREMENTS (CONT.)			
		<p>UNACCEPTABLE ENDFACE ANOMALIES SUB-SURFACE CRACKS</p> <p>Sub-surface cracks are only visible with core illumination, and are non-repairable. The fiber/assembly shall be reterminated or scrapped. NASA-STD-8739.5 [10.2.7.e]</p> <p>UNACCEPTABLE ENDFACE ANOMALIES SURFACE CRACKS-FLIGHT HARDWARE</p> <p>If cracks in a flight fiber optic assembly endface are found, the assembly shall be reterminated or scrapped. Repolishing to fix cracks in flight hardware is prohibited. NASA-STD-8739.5 [11.3.2]</p>	
		<p>UNACCEPTABLE ENDFACE ANOMALIES SURFACE CRACKS-GROUND SUPPORT</p> <p>If cracks in a flight fiber optic assembly endface are found, the assembly shall be reterminated or scrapped. Repolishing to fix cracks in flight hardware is prohibited. NASA-STD-8739.5 [11.3.2]</p> <p>UNACCEPTABLE ENDFACE ANOMALIES SURFACE PITS</p> <p>Repolish if in core or cladding. NASA-STD-8739.5 [10.2.7.e]</p>	
		<p>UNACCEPTABLE EPOXY BOND LINE CRACKS</p> <p>Cracks in the epoxy bond line shall be cause for rejection. NASA-STD-8739.5 [10.3.3.c], [11.5.3.c]</p> <p>UNACCEPTABLE FERRULE DAMAGE</p> <p>Cracks, damage or deformities on the ferrule shall be cause for rejection. NASA-STD-8739.5 [10.2.5.c], [11.2.3.c]</p>	
NASA WORKMANSHIP STANDARDS			
	<p>Released: 04.05.2002</p>	<p>Revision:</p>	<p>Revision Date:</p>



FIBER OPTICS GENERAL REQUIREMENTS (CONT.)	
<p>UNACCEPTABLE IMPROPER SPLICE CLOSURE INSTALLATION</p> <p>Splice closures shall be installed to provide environmental and mechanical protection to the splice section. As depicted, the splice closure does not completely cover the exposed fiber.</p> <p>NASA-STD-8739.5 [9.2.3.b], [10.2.7.f]</p>	<p>UNACCEPTABLE IMPROPER STRIP LENGTH</p> <p>Fibers designated for splicing or connectorization shall exhibit the proper cable and fiber stripping dimensions. Improper stripping dimensions may reduce reliability or performance.</p> <p>NASA-STD-8739.5 [10.2.4.a], [11.2.2.a]</p>
<p>UNACCEPTABLE KINKING</p> <p>Kinking produces microbends in the fiber, increasing signal attenuation and may promote breakage of the fiber.</p> <p>Best Workmanship Practice</p>	<p>UNACCEPTABLE LEAKS</p> <p>Light leakage is the result of a macrobend event in the fiber (i.e. crack, ship, etc.), causing a disruption in the light's transmission path.</p> <p>Best Workmanship Practice</p>

<p>UNACCEPTABLE MECHANICAL SPLICES BUBBLES</p> <p>Bubbles in the matching gel cavity will result in a high attenuation termination. The assembly shall be reterminated or scrapped.</p> <p>Best Workmanship Practice</p>	<p>UNACCEPTABLE MECHANICAL SPLICES END SEPARATION</p> <p>Typically seen in mechanical splices where the fiber ends are not in intimate contact, or in splices in which the matching gel has been lost/removed. High attenuation/ completely dark.</p> <p>Best Workmanship Practice</p>
---	---

NASA WORKMANSHIP STANDARDS			
 <p>NATIONAL AERONAUTICS AND SPACE ADMINISTRATION JOHNSON SPACE CENTER HOUSTON, TEXAS USA 77058</p>	Released: 04.05.2002	Revision:	Revision Date:
	Book: 10	Section: 10.01	Page: 9

**FIBER OPTICS
GENERAL REQUIREMENTS (CONT.)**

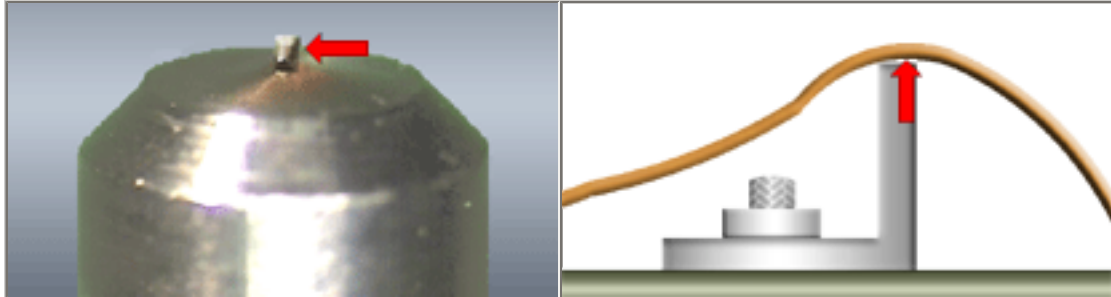

UNACCEPTABLE
PISTONING

The axial movement of the fiber within the connector body/ferrule causes pistoning. Positive pistoning may be fixable by repolishing. Negative pistoning shall be cause for rejection.

[NASA-STD-8739.5 \[10.3.3.b\], \[11.5.3.b\]](#)

UNACCEPTABLE
ROUTING

Optical fibers and cable assemblies shall not be routed over sharp edges or corners unless appropriate protection is provided.

[NASA-STD-8739.5 \[11.4.1\], \[12.2.8\], \[12.3.8\]](#)

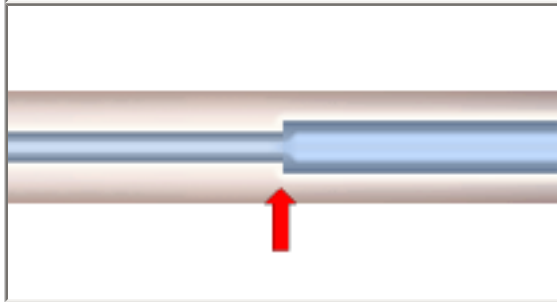

UNACCEPTABLE
SPLICES, CORE MISMATCH

Core mismatch is typically caused by the splicing of two differing fiber core sizes (i.e. 50/125 to 62.5/125). The splice can result in a power gain, or loss, depending on the direction of transmission.

[Best Workmanship Practice](#)

NASA WORKMANSHIP STANDARDS			
 NATIONAL AERONAUTICS AND SPACE ADMINISTRATION JOHNSON SPACE CENTER HOUSTON, TEXAS USA 77058	Released: 04.05.2002	Revision:	Revision Date:
	Book: 10	Section: 10.01	Page: 10



[Need a printed copy?](#)
(May take a while to load.)
Requires Adobe Reader.



[Need Adobe Reader?](#)
[Click here to download.](#)



[Questions? Suggestions?](#)

**FIBER OPTICS
FIBER OPTIC ASSEMBLIES**

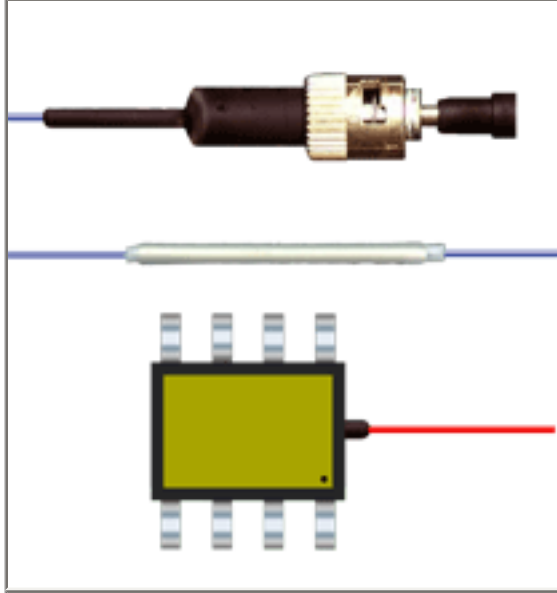

FIBER OPTIC ASSEMBLIES

Fiber optic assemblies include such devices as electro-optical components, star couplers, attenuators, repeaters, etc. The optical fibers in these devices consist of the coated fiber (core, cladding, coating), and differ from fiber optic cables, which are constructed with buffer layers, strength members and an outer jacket.

Optical fiber offers size and weight savings over optical cable, but additional attention must be paid to the protection of the fiber.

See Section 10.01 "Fiber Optics, General Requirements", for common accept/reject criteria.

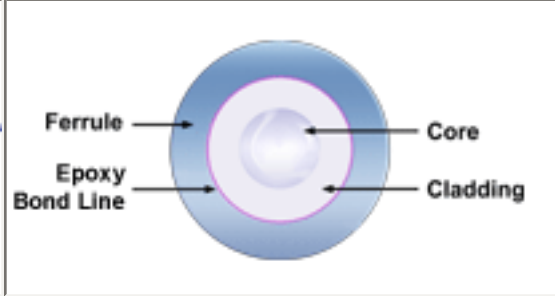
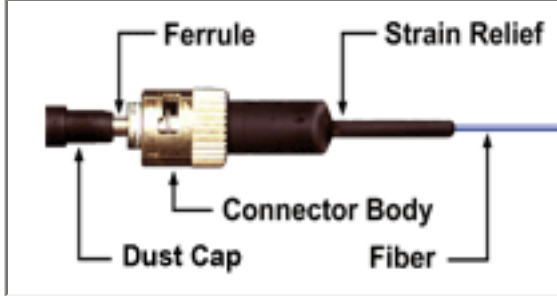

**PREFERRED
CONNECTOR/FIBER CONFIGURATION**

The connector is properly assembled. clean and damage-free. The connector and fiber strain-relief device(s) are properly installed, straight, tight and damage-free.

[NASA-STD-8739.5 \[11.3\]](#)

**ACCEPTABLE
ENDFACE**

The endface is clean and free from cracks, scratches, edge chips, hackles, pits and other anomalies. The fiber is concentric in the ferrule, and the epoxy ring is even.

[NASA-STD-8739.5 \[11.3.1.c\]](#)

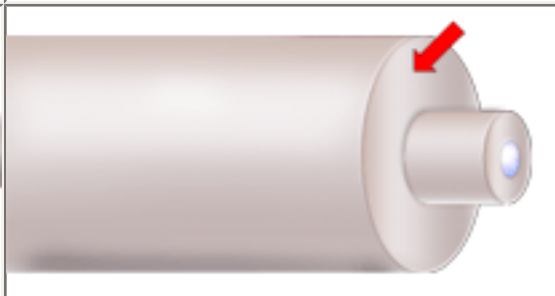
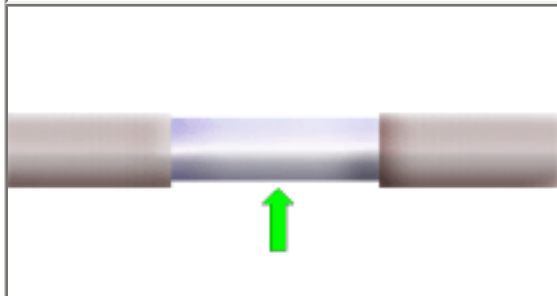

**ACCEPTABLE
FUSION SPLICE**

The splice is perfectly aligned. Fusion zone is of uniform diameter, with no bubbles, contamination or boundary layer evident.

[NASA-STD-8739.5 \[9.2.2.a\]](#)

**UNACCEPTABLE
BUFFER SHRINKAGE**

Shrinkage of the buffer shall be cause for rejection.

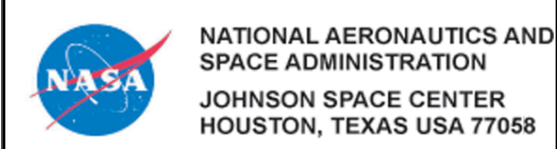

[NASA-STD-8739.5 \[11.5.3.d\]](#)

NASA WORKMANSHIP STANDARDS

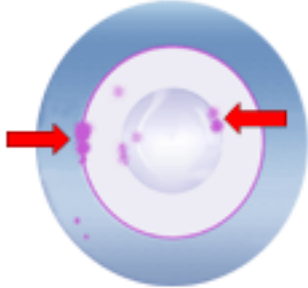
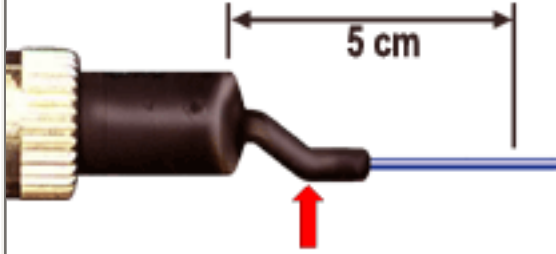

Released: 04.05.2002	Revision:	Revision Date:
-------------------------	-----------	----------------

	Book: 10	Section: 10.02	Page: 1
--	-------------	-------------------	------------

FIBER OPTICS FIBER OPTIC ASSEMBLIES (cont.)	
	
<p>UNACCEPTABLE EPOXY</p> <p>Epoxy deposits on the core, cladding or ferrule are rejectable. The deposits may be fixable by repolishing. NASA-STD-8739.5 [10.2.7.e]</p>	<p>UNACCEPTABLE IMPROPER FIBER ALIGNMENT</p> <p>Axial alignment of the fiber to the connector shall be maintained with 5 cm (2 in.) of the entry/exit from the connector body, to minimize stress on the termination and to minimize macrobend effects. Best Workmanship Practice</p>
	
<p>UNACCEPTABLE IMPROPER STRAIN RELIEF</p> <p>The strain relief shall be positioned and attached per engineering documentation. As depicted, the strain relief boot has not been installed. NASA-STD-8739.5 [10.2.7.f]</p>	

NASA WORKMANSHIP STANDARDS			
	Released: 04.05.2002	Revision: 	Revision Date:

 NATIONAL AERONAUTICS AND SPACE ADMINISTRATION JOHNSON SPACE CENTER HOUSTON, TEXAS USA 77058	Book:	Section:	Page:
	10	10.02	2





[Need a printed copy?](#)
(May take a while to load.)
Requires Adobe Reader.





[Need Adobe Reader?](#)
[Click here to download.](#)

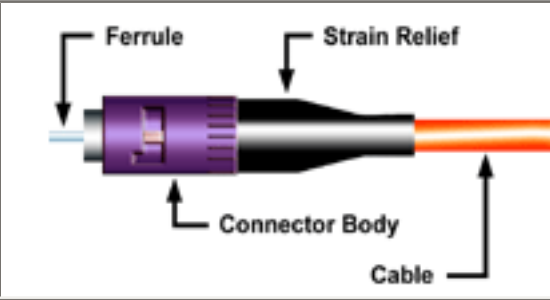
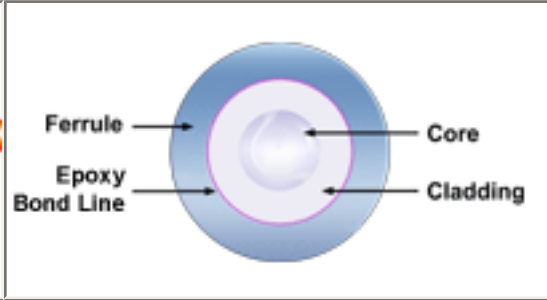
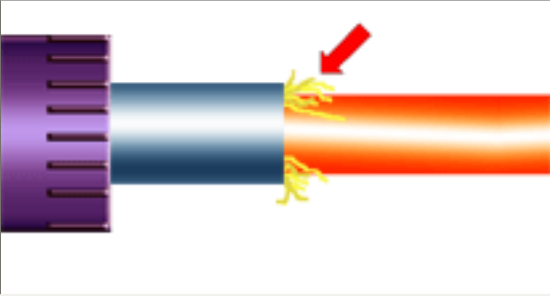
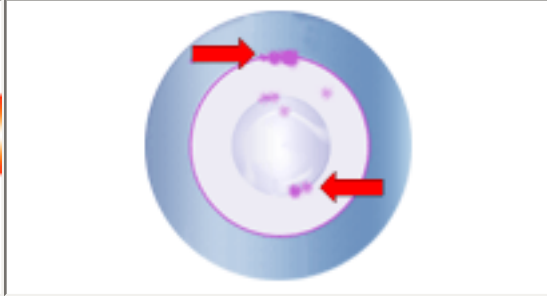

[Questions? Suggestions?](#)

FIBER OPTICS FIBER OPTIC CABLE ASSEMBLIES				
	<p style="text-align: center;"><u>FIBER OPTIC CABLE ASSEMBLIES</u></p> <p>A fiber optic cable assembly consists of a prepared fiber optic cable, connector and associated hardware.</p> <p>See Section 10.01 "Fiber Optics, General Requirements", for common accept/reject criteria.</p>			
				
<p>PREFERRED CONNECTOR/CABLE CONFIGURATION</p> <p>The connector is properly assembled. clean and damage-free. Strain-relief is properly installed, straight, tight and damage-free.</p> <p>NASA-STD-8739.5 [10.2.7]</p>	<p>ACCEPTABLE ENDFACE</p> <p>The endface is clean and free from cracks, scratches, edge chips, hackles, pits and other anomalies. The fiber is concentric in the ferrule, and the epoxy ring is even. Ferrule and connector are damage-free.</p> <p>NASA-STD-8739.5 [10.2.7]</p>			
				
<p>UNACCEPTABLE STRENGTH MEMBER</p> <p>The strength member shall be uniformly distributed and securely attached to the connector. The protruding fibers are a visual indication that the strength member has not been properly crimped to the connector bayonet.</p> <p>NASA-STD-8739.5 [10.2.7.a]</p>	<p>UNACCEPTABLE EPOXY</p> <p>Epoxy deposits on the core, cladding or ferrule are rejectable. The deposits may be fixable by repolishing.</p> <p>NASA-STD-8739.5 [10.2.7.e]</p>			
NASA WORKMANSHIP STANDARDS				
 <p>NATIONAL AERONAUTICS AND SPACE ADMINISTRATION JOHNSON SPACE CENTER HOUSTON, TEXAS USA 77058</p>	<table border="1" style="width: 100%;"> <tr> <td style="width: 33%;">Released: 04.05.2002</td> <td style="width: 33%;">Revision:</td> <td style="width: 33%;">Revision Date:</td> </tr> </table>	Released: 04.05.2002	Revision:	Revision Date:
Released: 04.05.2002	Revision:	Revision Date:		

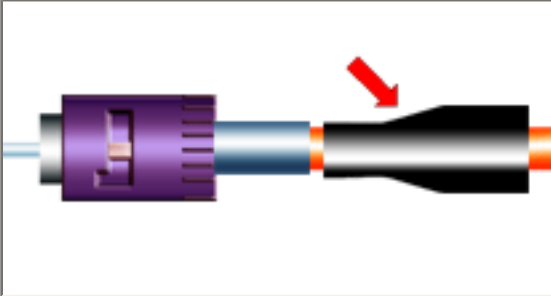
	Book: 10	Section: 10.03	Page: 1
--	-------------	-------------------	------------

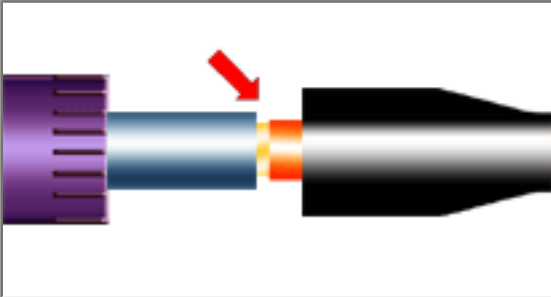
FIBER OPTICS FIBER OPTIC CABLE ASSEMBLIES (cont.)	
	
<p>UNACCEPTABLE IMPROPER STRAIN RELIEF</p> <p>The strain relief shall be positioned and attached per engineering documentation. The strain relief boot has been installed backwards - a common assembly error that can only be corrected by removing and replacing the connector.</p> <p>NASA-STD-8739.5 [10.2.7.f]</p>	<p>UNACCEPTABLE IMPROPER CABLE ALIGNMENT</p> <p>Axial alignment of the cable to the connector shall be maintained within 5 cm (2 in.) of the entry/exit from the connector body. This reduces strain on the connector assembly and minimizes signal attenuation effects.</p> <p>NASA-STD-8739.5 [10.2.7.h]</p>
	
<p>UNACCEPTABLE SHRINKAGE</p> <p>Shrinkage of the buffer, outer jacket, or other cable components, which result in reduced mechanical strength, reduced performance or attenuation losses in excess of engineering specification, shall be cause for rejection.</p> <p>NASA-STD-8739.5 [10.3.3.d], [11.5.3.d]</p>	

NASA WORKMANSHIP STANDARDS		
	Released: 04.05.2002	Revision: Revision Date:

 <p>NATIONAL AERONAUTICS AND SPACE ADMINISTRATION JOHNSON SPACE CENTER HOUSTON, TEXAS USA 77058</p>	Book: 10	Section: 10.03	Page: 2
---	-------------	-------------------	------------



[Need a printed copy?](#)
(May take a while to load.)
Requires Adobe Reader.



[Need Adobe Reader?](#)
[Click here to download.](#)

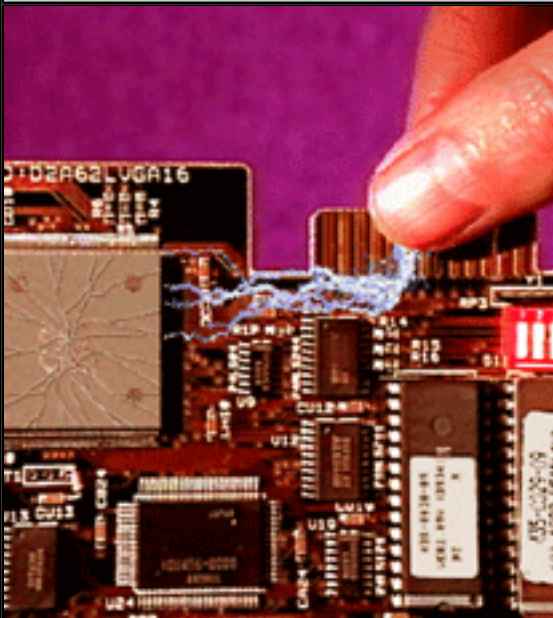

[Questions? Suggestions?](#)

ELECTROSTATIC DISCHARGE (ESD)
GENERAL REQUIREMENTSELECTROSTATIC DISCHARGE
(ESD)
GENERAL REQUIREMENTS

Electrostatic Discharge (ESD) is the rapid, uncontrolled discharge and transfer of accumulated electrical charge between two or more bodies at different electrical potentials, often resulting in significant Electrical Overstress (EOS) damage to sensitive electrical/electronic components.

The best prevention program is a combined effort aimed at the prevention and the controlled elimination of static charges, through the practice of proper behavior/procedures, workstation design and layout, environmental controls, tooling and component handling.



CLOTHING REQUIREMENTS

Non-static generating clothing shall be worn in ESD-protected areas or static dissipative smocks shall be worn as an outer garment. Finger cots and gloves, when worn in an ESD-protected area, shall be made of static dissipate, lint-free, particle-free materials.

[NASA-STD-8739.7 \[7.7\]](#)

HUMIDIFICATION

The relative humidity shall be monitored and maintained in ESD-protected work areas at 30% to 70%. At levels below 30%, additional precautions shall be employed (e.g. air ionizers, humidifiers, etc.).

[NASA-STD-8739.7 \[7.2.7\], \[9.2.1.d\]](#)

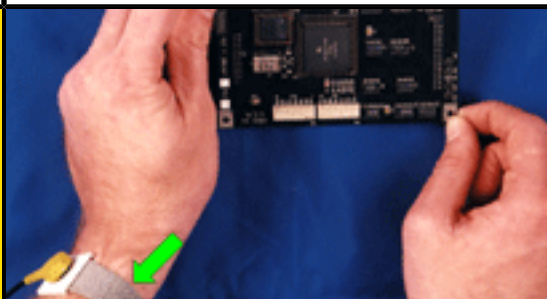

IDENTIFICATION/MARKING

ESDS items, equipment and assemblies shall be identified so as to warn personnel before any ESD damaging procedure can be performed.

[NASA-STD-8739.7 \[8.5\]](#)

PERSONNEL GROUNDING DEVICES

Personnel grounding devices (such as wrist straps) shall be supplied to all personnel working with or handling ESDS items to prevent the accumulation of dangerous electrostatic charge levels.

[NASA-STD-8739.7 \[7.2.5\], \[8.3\]](#)

NASA WORKMANSHIP STANDARDS

 NATIONAL AERONAUTICS AND SPACE ADMINISTRATION JOHNSON SPACE CENTER HOUSTON, TEXAS USA 77058	Released: 12.06.2001	Revision:	Revision Date:
	Book: 11	Section: 11.01	Page: 1

ELECTROSTATIC DISCHARGE (ESD) GENERAL REQUIREMENTS (cont.)

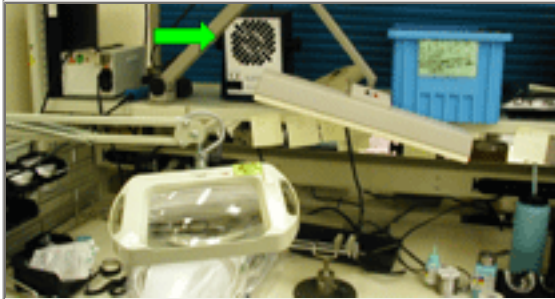

PREVENTATIVE EQUIPMENT

Air ionizers are recommended where grounding is impractical, where extremely ESD sensitive devices are used (<100V HBM), or where additional prevention against EOS/ESD are desired.

[NASA-STD-8739.7 \[7.2\]](#)



PROHIBITED MATERIALS

The area shall maintained in a clean and orderly condition. Smoking, eating and drinking in ESD-protected areas shall not be permitted. Unapproved tools, static generating materials, and/or materials unessential to the fabrication area are also prohibited at the workstation.

[NASA-STD-8739.7 \[7.2.2\]](#)



PROTECTIVE PACKAGING

Electrostatic protective packaging shall prevent the generation of charge and provide protection from strong electrostatic fields. Materials used shall satisfy the resistivity requirements to avoid triboelectric charge build-up.

[NASA-STD-8739.7 \[7.3\]](#)

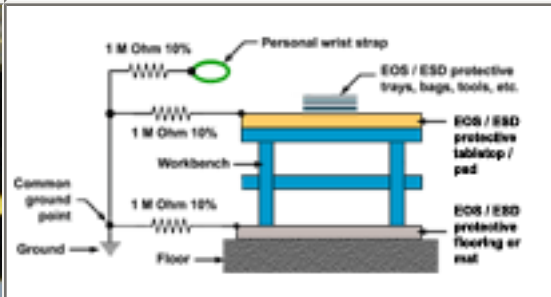

WORKSTATION GROUNDING SYSTEM

All work surfaces/workstations in an ESD-protected area shall be static dissipative and electrically connected to the common point ground system.

[NASA-STD-8739.7 \[7.2.3.a\]](#)



<p style="text-align: center;">WORKSTATION IDENTIFICATION/ ACCESS</p> <p>The ESD-protected area shall be clearly identified by prominently placed signs and marking systems (barrier tape, partition, rope guard, etc.). Access to such areas shall be limited to trained and equipped personnel.</p> <p>NASA-STD-8739.7 [7.2.1]</p>	<p style="text-align: center;">WRIST STRAP TESTING</p> <p>A wrist strap shall be available in all areas where ESDS items are handled. Wrist strap and foot ground devices shall be tested daily.</p> <p>NASA-STD-8739.7 [7.2.1], [7.6.3]</p>		
NASA WORKMANSHIP STANDARDS			
 <p>NATIONAL AERONAUTICS AND SPACE ADMINISTRATION JOHNSON SPACE CENTER HOUSTON, TEXAS USA 77058</p>	Released: 12.06.2001	Revision:	Revision Date:
	Book: 11	Section: 11.01	Page: 2



[Need a printed copy?](#)
(May take a while to load.)
Requires Adobe Reader.



[Need Adobe Reader?](#)
[Click here to download.](#)



[Questions? Suggestions?](#)

APPENDIX BEND RADIUS TABLE			
Conductor/ Cable Type	Optimum Bend Radius (O.D.)	Minimum Bend Radius (O.D.)	Space between constraint point to start of bend (O.D.)
Coaxial Cable	10	6	6
Coaxial Cable (Rigid)	3.5	2	6
Coaxial Cable (Semi-Rigid)	3.5	2	6
Component Lead (Flat)	2	1	0.5 mm (0.20 in.)
Component Lead (Round)	2	1	2
Fiber Optic Cable (Flight Applications)	15	10	10
Fiber Optic Cable (Mission Critical Ground Support)	15	10	10
Fiber Optic Cable (Hybrid)	20	10	10
Fiber Optic, Individual (Tight Buffer)	15	10	10
Flat Cable	10	3	3
Flat Cable (Shielded)	10	3	3
Harness (with coaxial cable, fiber optic or individual conductors 8 AWG or larger)	10	6	6
Harness (with individual conductors 10 AWG or smaller, no coaxial or fiber optic)	10	3	3
Harness with polyimide (Kapton®) insulated wires.	15	10	10
Individual Insulated Conductor	3	2	2
Multiconductor (Non-Shielded)	10	3	3
Multiconductor (Shielded)	10	6	6
Polyimide (Kapton®) Insulated	15	10	10
Ribbon Cable	10	3	3
Ribbon Cable (Shielded)	10	3	3
NASA WORKMANSHIP STANDARDS			
 NATIONAL AERONAUTICS AND SPACE ADMINISTRATION JOHNSON SPACE CENTER HOUSTON, TEXAS USA 77058	Released:	Revision:	Revision Date:
	07.31.2000	A	06.28.2002
	Book:	Section:	Page:
	12	12.01	1

APPENDIX CRIMP TERMINATIONS

Crimping is an efficient and highly reliable method to assemble and terminate contacts, pins, lugs, coaxial connectors and ferrules to stranded conductors for assembly into connector bodies. To ensure the quality of the crimp termination, destructive testing is performed on pre- and post-production run samples. Test values and visual examples of accept / reject criteria follow:

CRIMP PINS, SOCKETS & LUGS

Crimp Conductor Combination[* 1]		Minimum Axial Strength (Tensile) Pounds Force (Newtons)[* 2]				
Crimp Barrel Size	Wire Size (AWG)	Silver- or tin-plated Copper Wire	Nickel-plated Copper Wire	Copper Wire	High-Strength Copper Alloy Wire	
<p>LARGE</p> <p>SMALL</p>	08	08	-N/A-	-N/A-	288.0 (1281.1)	-N/A-
	10	10	-N/A-	-N/A-	159.0 (707.3)	-N/A-
	12	12	112.4 (500)	101.2 (450)	103.2 (459.1)	-N/A-
		14	71.9 (320)	60.7 (270)	65.1 (289.6)	-N/A-
	16	16	51.7 (230)	38.2 (170)	41.2 (183.3)	-N/A-
		18	34.8 (155)	-N/A-	32.0 (142.3)	-N/A-
		20	20.2 (90)	20.2 (90)	20.6 (91.6)	-N/A-
	20	20	20.2 (90)	13.5 (60)	20.6 (91.6)	-N/A-
		22	11.2 (50)	9 (40)	12.8 (56.9)	22.2 (98.7)
		24	9 (40)	6.7 (30)	-N/A-	14.4 (64.0)
	22 22D	22	11.2 (50)	9 (40)	12.8 (56.9)	22.2 (98.7)
		24	9 (40)	5.2 (23)	-N/A-	14.4 (64.0)
		26	-N/A-	-N/A-	-N/A-	8.0 (35.6)
		28	-N/A-	-N/A-	-N/A-	4.8 (21.3)
	22M 24	24	9 (40)	5.2 (23)	-N/A-	14.4 (64.0)
		26	-N/A-	-N/A-	-N/A-	8.0 (35.6)
		28	-N/A-	-N/A-	-N/A-	4.8 (21.3)
	26	26	-N/A-	-N/A-	-N/A-	10.8 (48)
		28	-N/A-	-N/A-	-N/A-	5.6 (25)
	28	28	-N/A-	-N/A-	-N/A-	5.6 (25)

SHIELD CRIMPS WITH GROUNDING LEAD[* 1, * 3]

	Wire Size (AWG)	Silver- or Tin-plated Copper Wire	Nickel-plated Copper Wire	Copper Wire	High-Strength Copper Alloy Wire
	20	20.2 (90)	13.5 (60)	20.6 (91.6)	-N/A-
	22	11.2 (50)	9 (40)	12.8 (56.9)	22.2 (98.7)
	24	9 (40)	6.7 (30)	-N/A-	14.4 (64.0)

NASA WORKMANSHIP STANDARDS			
 NATIONAL AERONAUTICS AND SPACE ADMINISTRATION JOHNSON SPACE CENTER HOUSTON, TEXAS USA 77058	Released:	Revision:	Revision Date:
	07.31.2000		
	Book:	Section:	Page:
	12	12.02	1

APPENDIX
CRIMP TERMINATIONS (cont.)

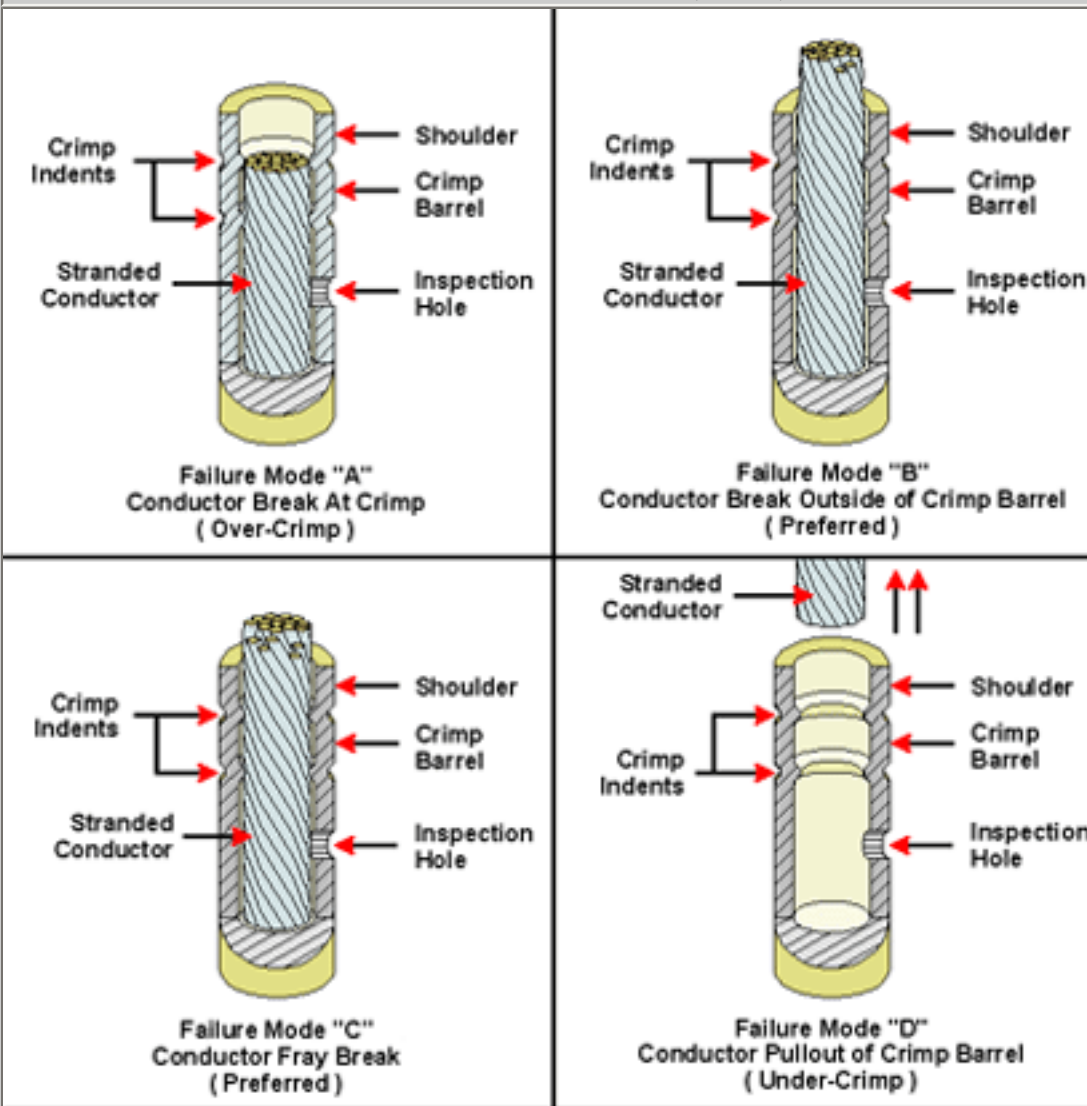

CRIMP JOINT TENSILE FAILURE CATEGORIES

[*] Notes:

1. Stranded wire only. Crimping of solid wire, and stranded wire that has been solder tinned, is prohibited.
2. For contact-conductor crimp combinations not listed in the table, the tensile strength of the crimp termination shall be no less than 60 percent of the tensile strength of the conductor.
3. Tensile values are for the ground lead-crimp termination only. Tensile tests are not typically performed on the shield-crimp termination.
4. Only full-cycle, ratcheting, non-user-adjustable tools shall be used.
5. Failure Modes: All Failure categories (modes) are acceptable, provided separation failure occurs above the minimum axial (tensile) strength.
6. Conductor breaks at the entrance of the contact wire barrel, caused by conductor cutting because the contact is not held squarely in the tester jaws, shall not be considered a preferred break.

NASA WORKMANSHIP STANDARDS			
 NATIONAL AERONAUTICS AND SPACE ADMINISTRATION JOHNSON SPACE CENTER HOUSTON, TEXAS USA 77058	Released:	Revision:	Revision Date:
	07.31.2000		
	Book:	Section:	Page:
	12	12.02	2

APPENDIX CRIMP TERMINATIONS (cont.)

Inspection and verification of assembled connectors shall include contact seating and retention tests, in applications in which the engaging (mating) ends of the pins or socket contacts are accessible.

Push Test: Push testing shall utilize a tool that minimizes the possibility of accidental contact bending and applies a controlled, preset pressure to the contact before releasing the force. Socket testing probes shall be undersized (compared to mating pin diameters) and shall not cause a mating cycle to occur.

Pull Test: Pull force contact retention testing shall be performed only on crimp-contact connectors in which the contact engaging (mating) ends are not accessible.

CONTACT RETENTION TEST[* 1]			
Contact Sizes		Push Test Force Pounds (Newtons)	Pull Test Force[* 2] Pounds (Newtons)
LARGE  SMALL	12	10 - 12 (44.5 - 53.4)	4 - 7 (17.8 - 31.1)
	16	8 - 10 (35.6 - 44.5)	4 - 7 (17.8 - 31.1)
	20	5 - 7 (22.2 - 31.1)	3 - 5 (13.3 - 22.2)
	22, 22D, 22M	4 - 6 (17.8 - 26.7)	3 - 5 (13.3 - 22.2)

[*] Notes:

1. For contacts not listed, refer to connector manufacturer's recommendations.
2. The listed values are based on a conductor size of 24 AWG. If a smaller wire gage is used, the listed values should be adjusted accordingly. Wire shall not be pulled to a force in excess of 80 percent of the specified minimum crimp tensile requirement. This requirement must be met to avoid damage to the wire / contact crimp joint.

NASA WORKMANSHIP STANDARDS			
 NATIONAL AERONAUTICS AND SPACE ADMINISTRATION JOHNSON SPACE CENTER HOUSTON, TEXAS USA 77058	Released:	Revision:	Revision Date:
	07.31.2000		
	Book:	Section:	Page:
	12	12.02	3

APPENDIX
ENVIRONMENTAL CONDITIONS

All Flight hardware fabrication operations shall be performed in a controlled environment that limits the entry of contamination. Environmental parameters shall be recorded and documented.

The appropriate temperature and humidity limits for the different assembly operations are given as follows:

Environmental Conditions	Temperature (°C / °F)		Humidity (% RH)	
	Lower Limit	Upper Limit	Lower Limit	Upper Limit
TASK OPERATIONS				
Cable & Harness Assembly	20 / 68	30 / 85	30	70
Conformal Coating	18 / 66	29 / 84	30	60
Crimping	18 / 66	32 / 90	10	90
Electrostatic Discharge (ESD) Protection	--N/A--	--N/A--	30 ¹ 40 ²	70 ¹ 60 ²
Encapsulating / Potting	18 / 66	29 / 84	30	60
Fiber Optic Cable Assembly	20 / 68	30 / 85	30	70
Hand Soldering (PWB)	20 / 68	30 / 85	30	70
Wire Wrap	18 / 66	32 / 90	10	90
Printed Wiring Board (PWB) Assembly	16 / 65	32 / 90	10	90
Staking	18 / 66	29 / 84	30	60
Surface Mount Technology (SMT)	16 / 65	30 / 85	30	60

Notes:

1.	Relative humidity ranges for Electrostatic Discharge (ESD) Protection
	1 Nominal % R.H.
	2 Desired % R.H.

2. Special Environmental Requirements. Parts or equipment being processed that require more stringent control of environmental conditions than those stated above, shall have those requirements and controls identified and specified in the engineering documentation.

NASA WORKMANSHIP STANDARDS			
 NATIONAL AERONAUTICS AND SPACE ADMINISTRATION JOHNSON SPACE CENTER HOUSTON, TEXAS USA 77058	Released:	Revision:	Revision Date:
	07.31.2000		
	Book:	Section:	Page:
	12	12.03	1

APPENDIX
ENVIRONMENTAL CONDITIONS (cont.)

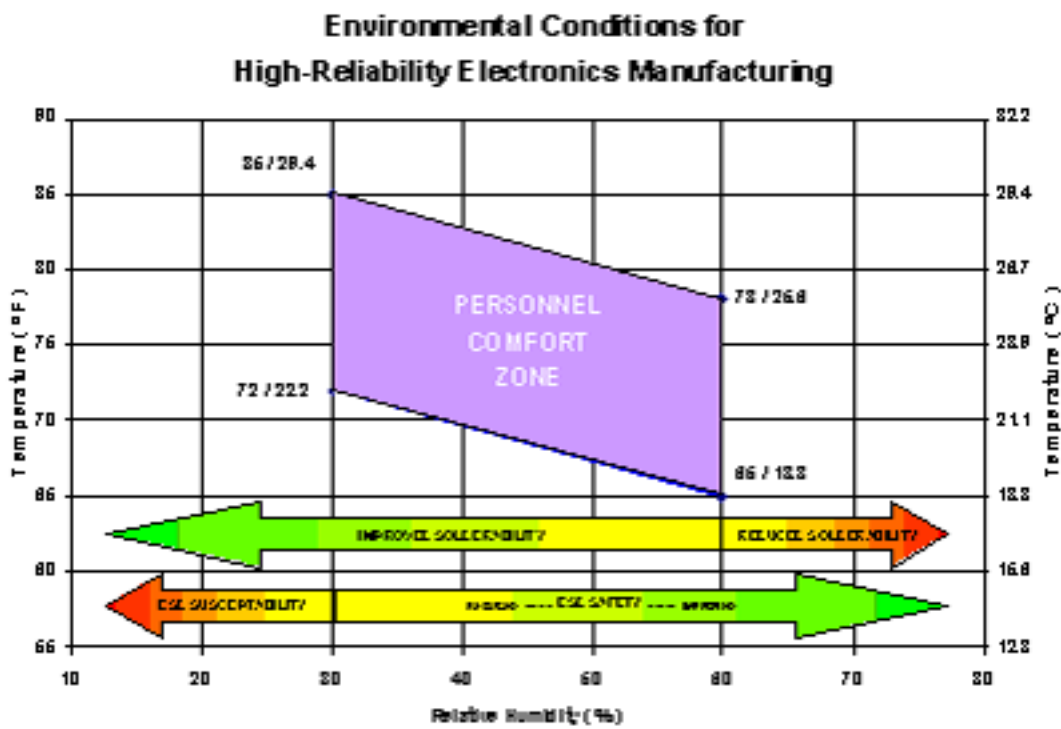

PERSONNEL COMFORT ZONE

The temperature and humidity of the work area shall be maintained within the limits defined as the comfort zone. The supplier shall monitor and maintain records of the work area temperature and humidity conditions.

LIGHTING

Light intensity shall be a minimum of 1077 Lumens per square meter (Lm/m²) or 100 foot-candles, measured on the work surface. Supplemental lighting may be used to achieve the required lighting levels.

VENTILATION SYSTEM

Areas used for cleaning parts, and areas where toxic or volatile vapors are generated, shall have an adequate ventilation system for removing air contaminants. The ventilation system shall comply with the recommendations and guidelines of the Occupational Safety and Health Administration (OSHA) requirement 29CFR.

REMOTE / FIELD OPERATIONS

In remote / field operations, the required controlled conditions cannot be effectively achieved. Special precautions shall be taken to minimize the effects of the uncontrolled environment on the operation being performed on the hardware. These precautions shall be identified in the appropriate engineering documentation.

NASA WORKMANSHIP STANDARDS			
 NATIONAL AERONAUTICS AND SPACE ADMINISTRATION JOHNSON SPACE CENTER HOUSTON, TEXAS USA 77058	Released:	Revision:	Revision Date:
	07.31.2000		
	Book:	Section:	Page:
	12	12.03	2

APPENDIX INSPECTION OPTICS

Inspection aids shall be selected appropriate to the item(s) or task(s) being inspected. Inspections shall be performed, using aids conforming to the following requirements:

1. Microscopes equipped with refractor boxes, oblique illumination (or other 45° angle viewing aids), video cameras, monitors, and/or still photographic capabilities are permissible.
2. Inspection light sources shall provide shadowless illumination.
3. The use of coherent light sources for inspection of fiber optic terminations shall be prohibited.
4. For inspection of solder connections, magnification aids that permit simultaneous viewing with both eyes (stereoscopic) are preferred, but not mandatory.
5. Use only glass optical elements.
6. The use of nondestructive inspection methods (e.g. x-ray, laser, and automated inspection systems) is permissible; however, the process shall be fully documented and shall not damage or degrade parts.

OPTICAL INSPECTION REQUIREMENTS	MAGNIFICATION POWER ^[* 1]	
	Lower Limit	Upper Limit
Operation / Task		
Cable & Harness Assembly	4X	10X
Conformal Coating (Requires black-light inspection)	4X	10X
Crimping	4X	10X
Electrostatic Discharge Protection (ESD)	--N/A--	--N/A--
Encapsulating/ Potting/ Underfill	4X	10X
Fiber Optic Cable Assembly ^[* 2]		
a. General	50X	80X
b. Endface/ Cleaved end inspection	100X	200X
Hand/ Through-Hole Soldering (NPTH/ PTH/ PWB)	4X	10X
Printed Wiring Board (PWB) Assembly	3X	10X
Staking / Bonding	4X	10X
Surface Mount Technology (SMT)		

a. Pre-soldering operations (Assembly / component placement / coplanarity / part alignment / paste testing / tinning)	4X	45X
b. Soldered connections: Land width $\geq 0.65\text{mm}$ (0.025")	10X	25X
c. Soldered connections: Land width $< 0.65\text{mm}$ (0.025")	25X	40X
d. Soldered connections: Land width $< 0.39\text{mm}$ (0.015")	25X	45X
e. Ball Grid Array (BGA) ^[* 3]	4X	45X
f. Chip-On-Board (COB) / Multi-Chip Module (MCM)	10X	200X
Wire Wrap	3X	10X

[*] Notes:

1. Additional magnification shall be used as necessary to resolve suspected defects.
2. **WARNING:** Extreme caution shall be exercised during the handling and optical inspection of fiber optics. Some light sources used in the testing and operation of fiber optics are extremely intense, may be operating in the visible or invisible spectrum, and can cause serious and permanent eye damage (often without any initial sensation of pain). Always assume an optical fiber is powered and operational, until confirmed otherwise !!
3. Three-dimensional (3-D) X-ray laminography is recommended.

NASA WORKMANSHIP STANDARDS			
 NATIONAL AERONAUTICS AND SPACE ADMINISTRATION JOHNSON SPACE CENTER HOUSTON, TEXAS USA 77058	Released:	Revision:	Revision Date:
	07.31.2000		
	Book:	Section:	Page:
	12	12.04	1

APPENDIX HARNESSTIE SPACING

Discrete wiring assembled into interconnecting cables or harnesses should be properly secured to ensure a highly reliable, robust assembly, providing proper stress relief and conductor support for the intended application.

All harness ties (i.e.: spot, plastic strap, stitch, etc.) shall be snug and properly spaced, without pinching or crushing the insulation, or bunching the conductors. Special attention should be given to harnesses containing coaxial and/or fiber optic cables, as these are extremely impedance-sensitive to crushing / deformation.

HARNESSTIE SPACING		
Harness Outer Diameter [O.D.] mm (inches)	Max. Distance Between Ties mm (inches)	Max. Distance From Connector or Connector Accessory To First Tie mm (inches)
≤ 6.4 (0.25)	19.1 (0.75)	25.4 - 50.8 (1 - 2)
12.7 (0.5)	38.1 (1.50)	25.4 - 50.8 (1 - 2)
25.4 (1.00)	50.8 (2.00)	50.8 - 76.2 (2 - 3)
> 25.4 (1.00)	76.2 (3.00)	76.2 - 101.6 (3 - 4)

[*] Notes:

1. Spot ties (lacing) shall consist of a clove hitch, followed by a square knot (or other non-slip knot).
2. Lacing tie ends shall be trimmed. When knots are to be staked, the necessary compounds, as well as any special design requirements shall be specified.
3. Plastic strap / cable ties (i.e.: Ty-Rapâ, etc.) should have metal tangs, and shall be of the locking / permanent design. The "ribbed" side of the strap shall be placed against the wires, and tightened to prevent movement on the assembly. Surplus strap ends shall be trimmed flush at the back of the strap head.
4. Ties shall be placed immediately before and immediately after any breakout of a wire or cable from the harness.

NASA WORKMANSHIP STANDARDS			
 NATIONAL AERONAUTICS AND SPACE ADMINISTRATION JOHNSON SPACE CENTER HOUSTON, TEXAS USA 77058	Released:	Revision:	Revision Date:
	07.31.2000	A	03.30.2001
	Book:	Section:	Page:
	12	12.05	1



[Need a printed copy?](#)
(May take a while to load.)
 Requires Adobe Reader.



[Need Adobe Reader?](#)
[Click here to download.](#)



[Questions? Suggestions?](#)

DEFINITIONS

Active Device

A discrete electronic component whose state (conductive) properties change when subjected to the application of an applied electrical signal (i.e.: diode, integrated circuit, transistor, etc.).

Attenuation

A reduction of signal amplitude (power), measured in decibels (db).

Best Workmanship Practice

A procedure, practice, or process attribute that has been demonstrated through use and experience, to result in a robust design and high reliability; but, which has not been identified as a specific attribute / requirement in the NASA Technical Standard series, NASA-STD-8739.

Blind Via

A via (plated-through hole) that extends to only one surface (primary / secondary) of a multilayer printed wiring board, with the other end terminating to an internal plane or land.

Breakdown / Roll-off

A surface irregularity associated with fiber optics, characterized by an angular shearing of a portion of the endface resulting in a rounded edge.

Buried Via

A via (plated-through hole) that does not extend to either surface of a multilayer printed wiring board, but instead terminates to internal planes / lands.

Chip-On-Board (COB)

A printed wiring board assembly process in which unpackaged die (or dice) are bonded to the board surface, and interconnected to the surrounding printed circuitry and/or adjacent die by wire bonding techniques.

Component Side

The primary side of a printed wiring board, from which through-hole components are typically inserted and which is opposite the solder application side of the board in solder wave assembly processes. The majority of the active circuit components typically populate the component / primary side. See also "Solder Side".

Dead-Bug

An industry nickname for the discrete components added and wired into a printed wiring assembly (PWA) to facilitate circuit modifications, rather than redesign and manufacture a new board. The nickname comes from their general appearance on the board: upside down, with their termination leads (legs) up in the air – like a dead bug.

Dice

Two or more die.

NASA WORKMANSHIP STANDARDS			
 NATIONAL AERONAUTICS AND SPACE ADMINISTRATION JOHNSON SPACE CENTER HOUSTON, TEXAS USA 77058	Released:	Revision:	Revision Date:
	05.31.2002		
	Book:	Section:	Page:
	13	13.01	1

DEFINITIONS (cont.)

Die

The basic, leadless form of an electronic component (active, passive, or integrated circuit) supplied on a silicon substrate / chip.

Discrete Component

A separate component that performs a single circuit function (i.e.: resistor, capacitor, diode, transistor, etc.).

Double-Sided Assembly

A printed wiring assembly (either double-side or multi-layer) with components mounted on both the primary (component) and secondary (solder) sides.

Drain Wire

An uninsulated wire that is used for the electrically conductive termination of a foil mylar shield or ground plane.

Edge Flash

A thin layer of insulation that is produced during the stripping of insulated conductors.

Fiducial Mark

An artwork feature that provides a visual guide for component orientation and mounting.

Hackle

A surface irregularity associated with fiber optics, and characterized by a jagged, rippled, or stepped break in the fiber face, similar in appearance to a stepped mountain range or the rough fur on a dog's back.

Haywire

A discrete conductor used to facilitate minor circuit modifications to printed wiring assemblies (PWA), rather than redesign and manufacture a new board. (a.k.a.: white wire, jumper).

Key

A mechanical device or feature in addition to, or in lieu of, a polarization feature that ensures the coupling of identical connectors / components can occur in only one orientation and only to similar keyed connectors / components.

Mist

See "Hackle"

Mixed Technology

A surface mount term, referring to the use of through-hole and surface mount components on the same printed wiring assembly.

Multilayer Printed Wiring Board

A rigid, flexible, or rigid-flex printed wiring board having three or more printed wiring board layers that are mechanically bonded together and electrically interconnected.

NASA WORKMANSHIP STANDARDS			
 NATIONAL AERONAUTICS AND SPACE ADMINISTRATION JOHNSON SPACE CENTER HOUSTON, TEXAS USA 77058	Released:	Revision:	Revision Date:
	05.31.2002		
	Book:	Section:	Page:
	13	13.01	2

DEFINITIONS (cont.)

Passive Device

A discrete electronic component whose state properties do not change when subjected to the application of an applied electrical signal (i.e.: resistor, capacitor, inductor, etc.).

Piggyback

The mounting of components on top of each other.

Pink Ring

A defect condition where the conductive layer around a through-hole / inner-layer interface has been stripped of its copper oxide coating, producing a "pinkish" coloration.

Popcorn

Popcorning is caused by the release of gas pressure entrapped in the component body during the soldering process. The effect can be relatively mild (body deformation) or can be destructive (seal breach or delidding). Popcorning is typically seen in plastic bodied devices that were exposed to an uncontrolled, high humidity environment during storage and/or assembly prior to soldering.

Primary Side

See "Component Side".

Reflow Soldering

The process of mass soldering a printed wiring assembly in which all (or a majority) of the components have been installed with a solder tinning, solder paste, or solder preform deposit between the component lead(s) and the land, and where the soldering process is completed by exposing the entire assembly to a heated environment sufficient to cause the solder deposits to flow.

Secondary Side

See "Solder Side".

Shadowing

A defect caused by the "blocking effect" of a component or other physical obstruction during the spray application of conformal coating, resulting in improper thickness or incomplete coverage.

Single-Sided Printed Wiring Board

A printed wiring board with a conductive pattern on only on side, typically the secondary (solder) side.

Solder Side

The secondary side of a printed wiring board, which is typically exposed to the application of solder during a mass soldering process (i.e. solder wave or solder fountain).

NASA WORKMANSHIP STANDARDS			
 NATIONAL AERONAUTICS AND SPACE ADMINISTRATION JOHNSON SPACE CENTER HOUSTON, TEXAS USA 77058	Released:	Revision:	Revision Date:
	05.31.2002		
	Book:	Section:	Page:
	13	13.01	3

DEFINITIONS (cont.)

Underfill

A polymeric substance injected under an electronic component to provide mechanical support and thermal conductivity.

Via

A plated through hole that is used as an interlayer electrical connection, but is sized to prevent the insertion of component lead or other reinforcing material.

NASA WORKMANSHIP STANDARDS			
 NATIONAL AERONAUTICS AND SPACE ADMINISTRATION JOHNSON SPACE CENTER HOUSTON, TEXAS USA 77058	Released:	Revision:	Revision Date:
	05.31.2002		
	Book:	Section:	Page:
	13	13.01	4



[Need a printed copy?](#)
(May take a while to load.)
 Requires Adobe Reader.



[Need Adobe Reader?](#)
[Click here to download.](#)



[Questions? Suggestions?](#)